

**Proline Model HPRT16-48 16" 48" Horizontal Pipe Roller**

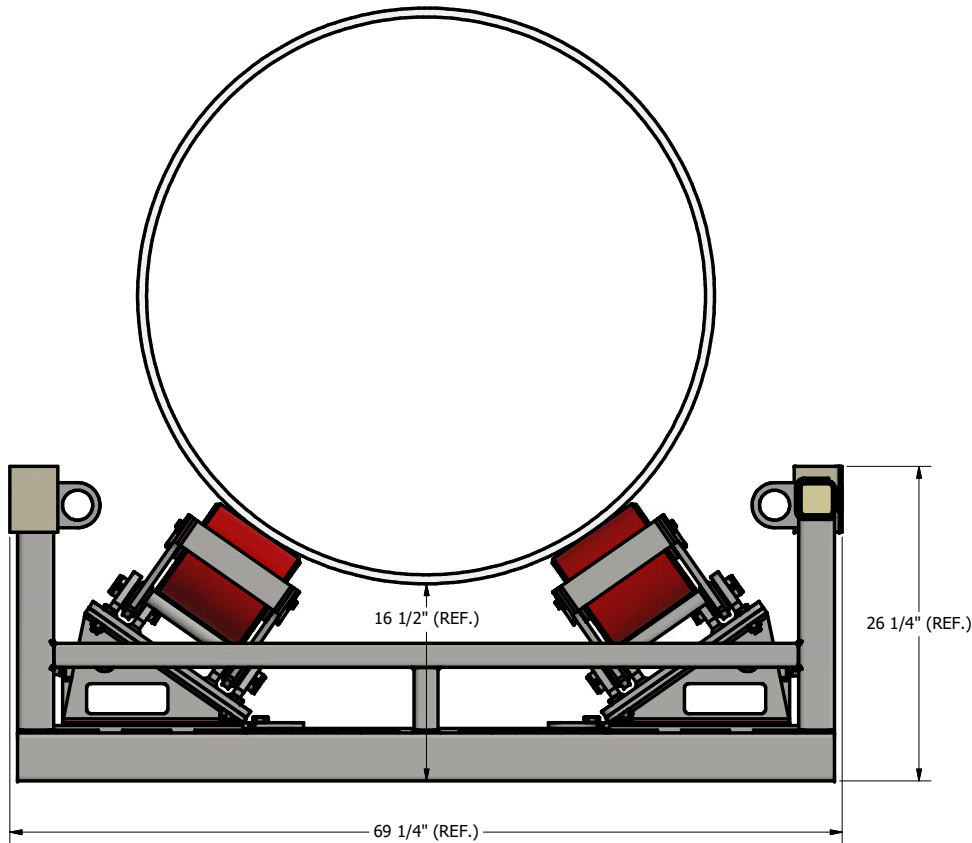
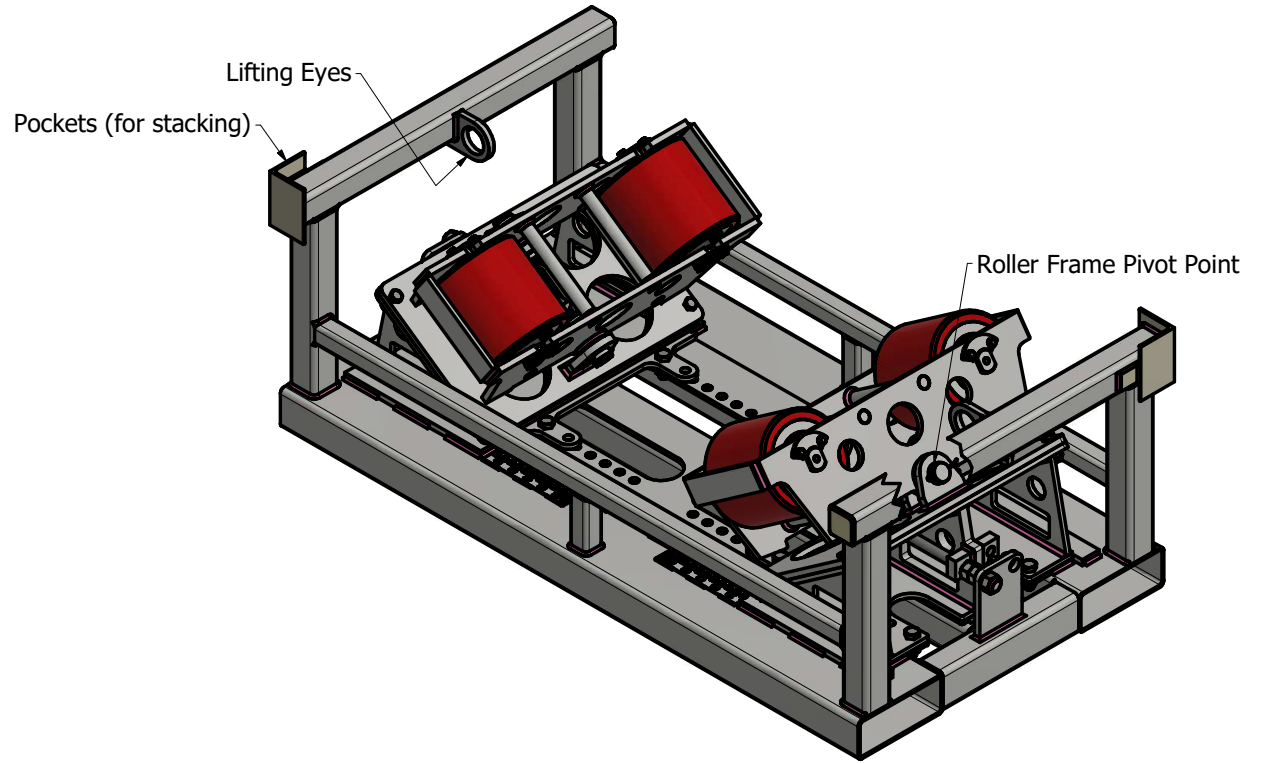

SHOWN SET ON 48" PIPE

Load Capacity: 50,000 Lbs.  
 Pipe Diameter Range: 16" to 48"  
 Weight: 1,605 Lbs.  
 Dimensions: 69 1/4" X 37 1/4" X 26 1/4"

Application: Heavy Duty Polyurethane Rollers designed to protect, support and guide a pipeline section during river/road crossing installations. Minimizes drag forces of pipe pulling.

Features:

- Angle Iron Pockets for ease of stacking.
- Fork lift pockets for positioning under pipe and loading on flatbed from all sides.
- 2 Lifting eyes
- Wide footprint for stability.
- Low ground profile
- Easily adjustable for different pipe sizes.
- Roller frames designed with center pivot points to allow each roller to be loaded equally. Pivots up to 14 degrees. (Useful for uneven terrain)