

**PARTS LIST**

ITEM	PART NUMBER	QTY	U.O.M.	DESCRIPTION
1	HB01-W001	1	EA	LIFTING BEAM WELDMENT
2		4	EA	SWIVEL HOOK W/ LATCH - CROSBY 1 TON - 1048612
3		4		STEEL CLEVIS PIN & COTTER PIN - MCMASTER CARR - 97245A709

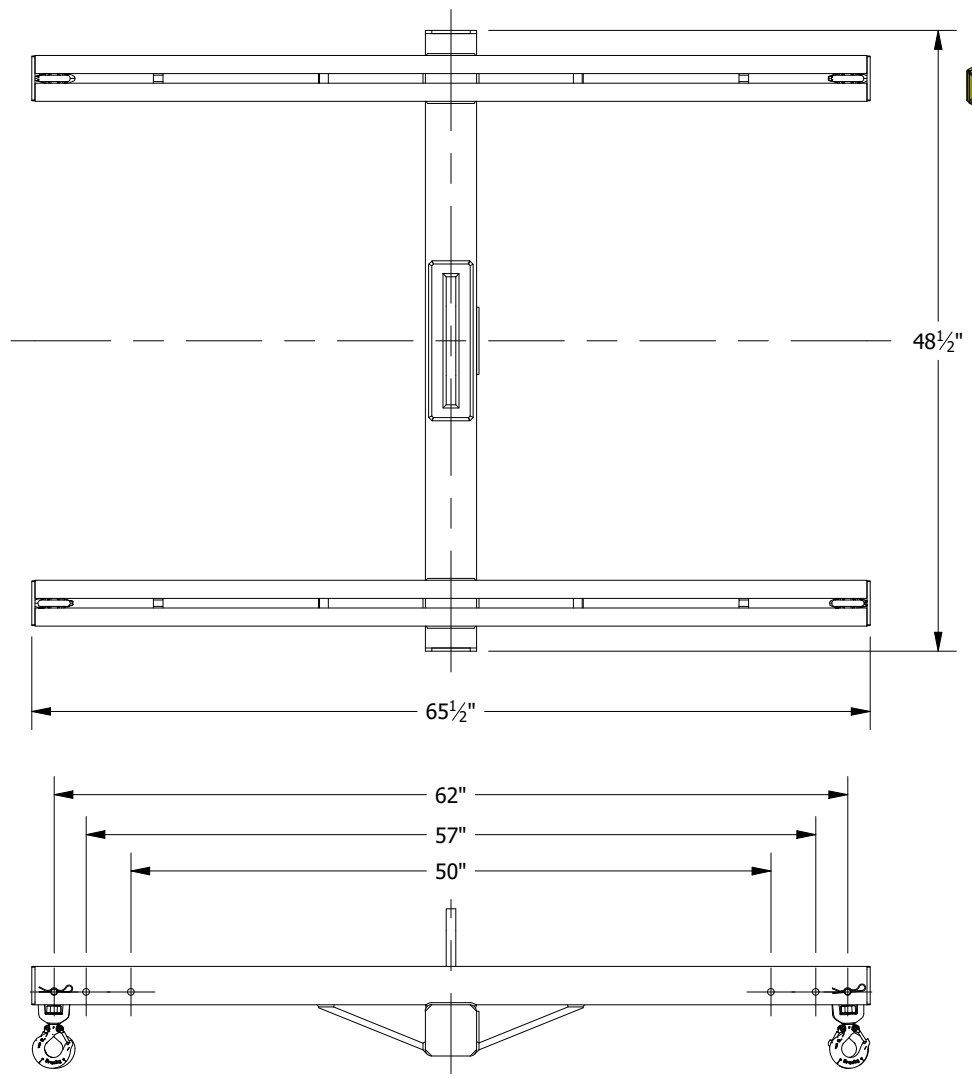

**S.W.L. = 1 TON (2,000 LBS)**  
**ASME BTH-1 DESIGN CATEGORY: B**  
**ASME BTH-1 SERVICE CLASS: 2**

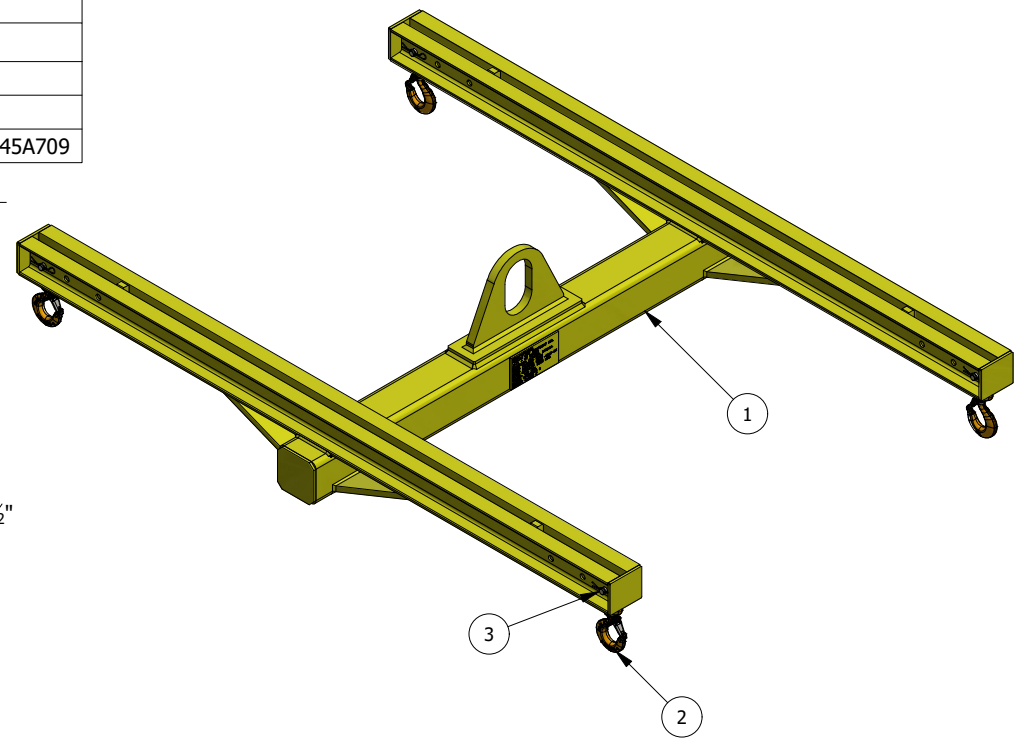
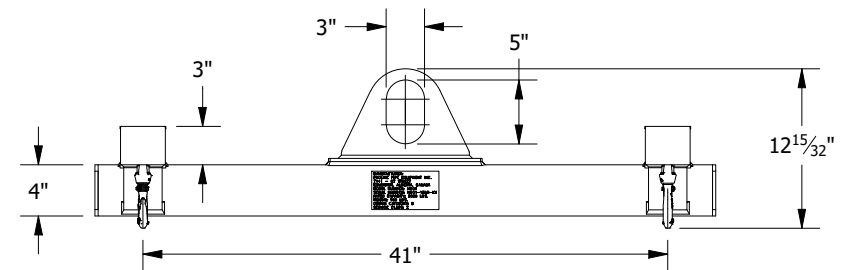

**MASS: 180 lbmass**

<b>DWG #:</b> HB01-A001	DIMENSIONS ARE IN INCHES UNLESS STATED OTHERWISE
<b>DESC:</b> H STYLE LIFTING BEAM ASSEMBLY	TOLERANCE OF FRACTIONAL DIMENSIONS TO BE ± 1/32" UNLESS OTHERWISE NOTED
<b>PARENT:</b>	
<b>PHASE:</b>	TOLERANCES UNLESS OTHERWISE SPECIFIED:
<b>PROJECT:</b> H STYLE LIFTING BEAM - 1 TON	.XXX ± 0.005" ANGLES ± 1/2 °
<b>PROCESS:</b> ASSEMBLY	.XX ± 0.015" SURFACES 125
	.X ± 0.030"

**PROLINE** 7141 67 STREET  
 EDMONTON, ALBERTA  
 CANADA T6E 4M9  
 780.465.6161

**PIPE EQUIPMENT INC.**

THIS DRAWING REMAINS THE EXCLUSIVE PROPERTY OF PROLINE PIPE EQUIPMENT INC. IT IS ILLEGAL TO USE THIS DRAWING FOR FABRICATION PURPOSES UNLESS SPECIFICALLY AUTHORIZED BY PROLINE PIPE EQUIPMENT INC.

SHEET SIZE: A SCALE: 1:15 SHEET 1 OF 1

**REVISION HISTORY**

REV	DATE	BY	DESCRIPTION
0	2021-09-10	DB	ISSUE FOR MANUFACTURE