

TeSi
INDUCTION HEATING

**INDUCTION HEATING GENERATOR
IHG 120CU**

**USE AND MAINTENANCE
INSTRUCTIONS**

CE



Publication No. 030113

Via Piave, 20/11
20080 Vermezzo - Milano - ITALY
Tel. 0039 - 02 - 9440501 - Fax 0039 - 02 - 9449087
<http://www.tesigroup.com>
e-mail: info@tesigroup.com

LIST OF THE VALID PAGES

This publication consists of 200 pages, which are so subdivided:

No. OF PAGES	REVISION	BASE
from I to XVI	00	November 2012
CHAPTER 1 From 1-1 to 1-14	00	November 2012
CHAPTER 2 From 2-1 to 2-30	00	November 2012
CHAPTER 3 From 3-1 to 3-12	00	November 2012
CHAPTER 4 From 4-1 to 4-12	00	November 2012
CHAPTER 5 From 5-1 to 5-14	00	November 2012
CHAPTER 6 From 6-1 to 6-48	00	November 2012
CHAPTER 7 From 7-1 to 7-20	00	November 2012
CHAPTER 8 From 8-1 to 8-24	00	November 2012
CHAPTER 9 From 9-1 to 9-2	00	November 2012
CHAPTER 10 From 10-1 to 10-8	00	November 2012

PAGE LEFT
INTENTIONALLY BLANK

ADDITIONS' AND VARIANTS' RECORD

REVISION	DESCRIPTION
01	
02	
03	
04	
05	

REVISION	DESCRIPTION
06	
07	
08	
09	
10	
11	
12	
13	

TABLE OF CONTENTS

INDEX OF THE TEXT

CHAPTER 1	INTRODUCTION	1-1
1.1	INDUCTION HEATING GENERATOR IHG 150CU IDENTIFICATION DATA.....	1-2
1.2	IDENTIFICATION OF THIS PUBLICATION.....	1-6
1.3	JOINED PUBLICATIONS.....	1-6
1.4	PURPOSE OF THIS PUBLICATION	1-6
1.5	USE OF THIS MANUAL.....	1-6
1.6	REVISION.....	1-7
1.7	CONVENTIONS FOR DEFINING THE ORIENTATION.....	1-7
1.8	GLOSSARY AND ABBREVIATIONS	1-8
1.8.1	Glossary.....	1-8
1.8.2	Abbreviations	1-8
1.9	SAFETY WARNINGS	1-9
1.9.1	General warnings.....	1-9
1.9.2	Personnel qualification.....	1-9
1.9.3	Personal safety means	1-10
1.9.4	Safety transfer printings	1-10
1.10	PERSONNEL TRAINING.....	1-12
1.11	CUSTOMER SERVICE.....	1-12
1.11.1	After-sales technical service	1-13
1.11.2	Spare parts	1-14
CHAPTER 2	GENERAL TECHNICAL INFORMATION	2-1
2.1	FOREWORD.....	2-2
2.1.1	Use destination	2-2
2.1.2	Operator.....	2-2
2.1.3	Work environment.....	2-2
2.1.4	Environmental requirements	2-2
2.1.5	Noise emission.....	2-4
2.2	GENERAL DESCRIPTION	2-4
2.2.1	Generator.....	2-7
2.2.1.1	Engine.....	2-11
2.2.1.2	Generator alternator.....	2-11
2.2.1.3	Capacitors.....	2-12

2.2.1.4	Command and control panel.....	2-13
2.2.1.5	Output power connectors.....	2-15
2.2.1.6	Batteries.....	2-15
2.2.2	COILS	2-17
2.2.2.1	Standard clamp coil	2-17
2.2.2.2	Heavy duty clamp coil.....	2-19
2.2.2.3	Pair of external ring coils.....	2-21
2.2.2.4	Pair of internal ring coils.....	2-21
2.2.3	Remote control.....	2-22
2.2.4	Power cables	2-23
2.2.5	Compressed air system (optional)	2-23
2.2.6	120 Vac auxiliary generator (optional)	2-25
2.2.7	Battery charger (optional)	2-27
2.3	INDUCTION HEATING GENERATOR IHG 150CU TECHNICAL DATA.....	2-28
2.3.1	Generator dimensions and weight	2-28
2.3.2	Mechanical characteristics.....	2-29
2.3.2.1	Engine.....	2-29
2.3.2.2	Compressed air system (Optional)	2-29
2.3.3	Electric characteristics	2-29
2.3.4	Coils' dimensions and weight.....	2-29
2.3.5	Power cables dimensions and weight.....	2-29
2.3.6	Packings' dimensions and weight	2-29
2.3.6.1	Wooden base.....	2-29
2.3.6.2	Wooden crate.....	2-30
2.3.6.3	Pallet.....	2-30
CHAPTER 3	SAFETY RULES	3-1
3.1	SAFETY GENERAL PRINCIPLES.....	3-2
3.2	SAFETY INFORMATION	3-3
3.3	EMERGENCY BEHAVIOURS	3-5
3.3.1	Fire.....	3-6
3.3.2	Lubricants	3-6
3.3.2.1	Lubricants' first aid	3-6
3.3.3	Scalds	3-6
3.3.4	Carbon monoxide intoxications.....	3-6
3.3.5	Corrosions.....	3-7
3.3.6	Fulgurations	3-7
3.3.7	Wounds and fractures.....	3-7
3.3.8	Elastomeric materials.....	3-7
3.3.8.1	First aid	3-8
3.4	SAFETY IN MAINTENANCE	3-8
3.5	SAFETY DEVICES	3-10
3.5.1	Emergency pushbutton	3-10
3.5.2	Hoisting accessories	3-11
3.5.3	Electric plant	3-11
3.5.4	Electric safety devices	3-11
3.5.5	Command and control panel protective transparent hatch	3-11
3.5.6	Grounding	3-12

CHAPTER 4	PACKING, HANDLING, TRANSPORT, RECEPTION, STORAGE AND DISMANTLING	4-1
4.1	GENERAL WARNINGS	4-2
4.2	PRELIMINARY OPERATIONS	4-2
4.3	PACKING	4-3
4.4	INDUCTION HEATING GENERATOR IHG 150CU HANDLING.....	4-5
4.4.1	Handling by using a crane	4-6
4.4.1.1	Hooking procedure.....	4-6
4.4.2	Handling by using a forklift truck.....	4-7
4.4.2.1	Procedure	4-8
4.4.2.2	Procedure	4-8
4.5	TRANSPORT	4-9
4.6	CHECK AT GOODS' RECEPTION	4-9
4.7	STORAGE	4-9
4.7.1	General	4-9
4.7.2	Environmental requirements.....	4-9
4.7.3	Operations to be carried out before storing the induction heating generator IHG 150CU	4-10
4.8	DISMANTLING	4-10
CHAPTER 5	INSTALLATION	5-1
5.1	GENERAL WARNINGS	5-2
5.2	REMOVAL OF THE PROTECTIVE PACKINGS AND PRELIMINARY OPERATIONS	5-2
5.3	HANDLING	5-2
5.4	INSTALLATION OF THE INDUCTION HEATING GENERATOR IHG 150CU	5-2
5.4.1	Minimum distances to be observed during the generator installation.....	5-2
5.4.2	Switch on the batteries switch.....	5-4
5.4.3	Positioning of the induction heating generator IHG 150CU	5-4
5.4.4	Preliminary operations to be carried out on the generator.....	5-6
5.4.5	Electric connections between generator and coil	5-9
5.4.5.1	Coupling of the power connectors	5-11
5.4.5.2	Uncoupling of the power connectors.....	5-12
5.4.6	Generator grounding.....	5-13
5.4.7	Remote control electric connection.....	5-14
CHAPTER 6	USE	6-1
6.1	GENERAL WARNINGS	6-2
6.2	COMMANDS AND CONTROLS	6-2
6.2.1	General	6-2
6.2.2	Command and control panel.....	6-2
6.2.2.1	Display	6-4
6.2.3	Remote control.....	6-11
6.3	PRELIMINARY CHECKS.....	6-12
6.4	USE.....	6-13
6.4.1	Preliminary operations to be carried out before starting the engine	6-15
6.4.2	Engine starting.....	6-17
6.4.3	Setting operations	6-19
6.4.3.1	General	6-19

6.4.3.2	Setting of the heating time	6-19
6.4.3.3	Setting of the pipe temperature (Optional).....	6-21
6.4.3.4	Setting of the generator output power	6-23
6.4.4	Coils' positioning on the pipe	6-25
6.4.4.1	Standard clamp coil	6-25
6.4.4.2	Heavy duty clamp coil.....	6-28
6.4.4.3	Pair of external ring coils.....	6-35
6.4.4.4	Pair of internal ring coils.....	6-36
6.4.5	Power factor correction	6-37
6.4.5.1	Operating mode set on "auto" (default parameter)	6-37
6.4.5.2	Operating mode set on "man"	6-37
6.4.6	Operation	6-39
6.4.6.1	General	6-39
6.4.6.2	Manual mode	6-40
6.4.6.3	Automatic mode with timer.....	6-40
6.4.6.4	Automatic mode with temperature probe (Optional)	6-40
6.4.7	Checks to be carried out during operation.....	6-41
6.5	COMPRESSED AIR SYSTEM (OPTIONAL)	6-42
6.6	120 VAC AUXILIARY GENERATOR (OPTIONAL)	6-43
6.7	BATTERY CHARGER (OPTIONAL)	6-44
6.8	LOGGER (OPTIONAL).....	6-45
6.8.1	Heating cycles logger.....	6-46
6.8.2	Alarms logger.....	6-46
6.8.3	Events logger.....	6-47
6.9	DOWNLOAD THE LOGGER'S DATA FILE (OPTIONAL).....	6-48
CHAPTER 7	MAINTENANCE	7-1
7.1	GENERAL WARNINGS	7-2
7.2	INTRODUCTION	7-2
7.3	CUSTOMER/OPERATOR SERVICE.....	7-2
7.4	AUTHORIZED PERSONNEL	7-2
7.5	ROUTINE MAINTENANCE.....	7-2
7.5.1	Check and possibly clean the air intake grate	7-3
7.5.2	Check and possibly clean the air exhaust grate	7-4
7.5.3	Check the correct execution of the automatic test in the generator power supply phase..	7-4
7.5.4	Clean the commands and controls situated on the command and control panel	7-5
7.5.5	Check the correct operation of the exhaust valve, and possibly lubricate the relevant fastening pin.....	7-5
7.5.6	Check the engine oil correct level and topp it up, if necessary	7-6
7.5.7	Check the engine coolant correct level and top it up, if necessary	7-7
7.5.8	Check and possibly replace the air filter cartridge of the compressed air system (optional).....	7-9
7.5.9	Check and possibly clean the air filter desiccator of the compressed air system (optional).....	7-10
7.6	PERIODICAL PREVENTIVE MAINTENANCE	7-10
7.6.1	Check the power connectors, situated on the generator, on the coil and on the power cables between generator and coil	7-12

7.6.2	Check the wear of the insulating material of the power cables between generator and coil.....	7-13
7.6.3	Generally check the wear of the insulating material of the generator internal power cables and the tightening of the power wiring clamping screws and nuts	7-13
7.7	CORRECTIVE MAINTENANCE	7-14
7.7.1	Electronic cards' replacement.....	7-15
7.7.2	Fuses F1, F2, F3, F4, F5 and F8 replacement	7-17
7.7.3	Fuse F0 replacement.....	7-18
7.7.4	Resetting of the automatic breaker "QS1"	7-19
CHAPTER 8	DIAGNOSTICS	8-1
8.1	GENERAL.....	8-2
8.1.1	Inconveniences which can be visualized on the display	8-2
8.1.2	Troubleshooting	8-23
CHAPTER 9	AVAILABLE OUTFITS	9-1
9.1	GENERAL.....	9-2
CHAPTER 10	MAINTENANCE SERVICE TABLES	10-1
10.1	GENERAL.....	10-2

INDEX OF THE TABLES

Table	Page
CHAPTER 1	
1.1 - Safety transfer printings	1-10
CHAPTER 4	
4.1 - Weights	4-5
4.2 - Materials composing the Induction Heating Generator IHG 150CU.....	4-10
CHAPTER 6	
6.1 - Commands and controls situated on the command and control panel	6-2
6.2 - List of the parameters to be visualized on the display.....	6-7
6.3 - Commands and controls present on the remote control	6-11
6.4 - Coils identification plate.....	6-23
CHAPTER 7	
7.1 - Routine maintenance	7-3
7.2 - Mechanical scheduled maintenance	7-11
7.3 - Electric preventive maintenance	7-11
7.4 - Corrective maintenance	7-14
CHAPTER 8	
8.1 - Inconveniences which can be visualized on the display	8-2
8.2 - Engine alarms which can be visualized on the display	8-13
8.3 - Troubleshooting.....	8-23

INDEX OF THE ILLUSTRATIONS

Figure	Page
CHAPTER 1	
1.1 - Induction Heating Generator IHG 150CU identification plates (Sheet 1 of 5).....	1-2
1.1 - Induction Heating Generator IHG 150CU identification plates (Sheet 2 of 5).....	1-3
1.1 - Induction Heating Generator IHG 150CU identification plates (Sheet 3 of 5).....	1-4
1.1 - Induction Heating Generator IHG 150CU identification plates (Sheet 4 of 5).....	1-5
1.1 - Induction Heating Generator IHG 150CU identification plates (Sheet 5 of 5).....	1-5
CHAPTER 2	
2.1 - Max longitudinal and transversal gradients when using the Induction Heating Generator IHG 150CU	2-3
2.2 - Induction Heating Generator IHG 150CU configuration (Sheet 1 of 2).....	2-5
2.2 - Induction Heating Generator IHG 150CU configuration (Sheet 2 of 2).....	2-6
2.3 - Displacement of the parts composing the generator (Sheet 1 of 3).....	2-8
2.3 - Displacement of the parts composing the generator (Sheet 2 of 3).....	2-9
2.3 - Displacement of the parts composing the generator (Sheet 3 of 3).....	2-10
2.4 - Generator alternator.....	2-11
2.5 - Capacitor battery and capacitor contactors.....	2-12
2.6 - Command and control panel.....	2-13
2.7 - Electric board, housing the components representing the control system.....	2-14
2.8 - Output power connectors, situated on the generator.....	2-15
2.9 - Batteries.....	2-16
2.10 - Standard clamp coil.....	2-18
2.11 - Heavy duty clamp coil.....	2-20
2.12 - External riving coil.....	2-21
2.13 - Internal ring coil.....	2-21
2.14 - Remote control.....	2-22
2.15 - Power cables.....	2-23
2.16 - Compressed air system (Optional) (Sheet 1 of 2).....	2-24
2.16 - Compressed air system (Optional) (Sheet 2 of 2).....	2-25
2.17 - 120 Vac auxiliary generator (Optional).....	2-26
2.18 - Battery charger (Optional).....	2-27
2.19 - Generator overall dimensions.....	2-28
CHAPTER 3	
3.1 - Emergency pushbutton.....	3-10
3.2 - Command and control panel protective transparent hatch.....	3-12
3.3 - Grounding point.....	3-12
CHAPTER 4	
4.1 - Switch OFF the battery switch.....	4-2
4.2 - Draining fuel from tank.....	4-3
4.3 - Packing and displacement of the cardboard box containing the “accessories”.....	4-3
4.4 - Packing.....	4-4

4.5 - Generator hooking.....	4-6
4.6 - Coil hooking.....	4-7
4.7 - Generator handling, by using a forklift truck.....	4-8
4.8 - Power cables handling	4-9

CHAPTER 5

5.1 - Minimum distances to be observed during the generator installation	5-3
5.2 - Switch ON the batteries switch.....	5-4
5.3 - Max longitudinal and transversal gradients when using the Induction Heating Generator IHG 150CU	5-5
5.4 - Preliminary operations to be carried out on the generator (Sheet 1 of 2)	5-7
5.4 - Preliminary operations to be carried out on the generator (Sheet 2 of 2)	5-8
5.5 - Electric connections between coil and generator	5-9
5.6 - Arrangement of the power cables	5-11
5.7 - Coupling of the power connectors.....	5-11
5.8 - Uncoupling of the power connectors	5-12
5.9 - Generator grounding	5-13
5.10 - Remote control electric connection	5-14

CHAPTER 6

6.1 - Commands and controls of the command and control panel.....	6-4
6.2 - Visualization menu of the parameters relevant to the heating function and to the engine working.....	6-5
6.3 - Visualization menu of the generator working and use parameters setting (flow diagram).....	6-6
6.4 - Visualization and setting menu of the value of a parameter (flow diagram).....	6-9
6.5 - Visualization and setting of the value of a password protected parameter (flow diagram)	6-10
6.6 - Commands and controls present on the remote control	6-11
6.7 - Air intake and exhaust grates.....	6-12
6.8 - Command and control panel	6-13
6.9 - Max longitudinal and transversal gradients when using the Induction Heating Generator IHG 150CU ..	6-14
6.10 - Batteries switch	6-15
6.11 - Transparent hatch opening and locking	6-15
6.12 - Preliminary operations.....	6-16
6.13 - Opening of the access door to the engine (rear part).....	6-17
6.14 - Fuel scavenge hand pump.....	6-18
6.15 - Timer for setting the heating time	6-20
6.16 - Temperature transducer connector	6-21
6.17 - K thermocouple type temperature probe.....	6-21
6.18 - Setting of the pipe temperature (Optional)	6-22
6.19 - Generator and alternator	6-23
6.20 - Pushbuttons UP + and DOWN - for setting the generator output power.....	6-24
6.21 - Knob for releasing/locking the handle and release of the hook levers from the clamp coil pins	6-25
6.22 - Positioning of the clamp coil onto the pipe	6-26
6.23 - Coupling of the contacts for the (knife) turns' closing.....	6-26
6.24 - Hooking of the hook levers to the pins	6-27
6.25 - Clamp coil closing	6-27
6.26 - Locking of the handle for opening/closing the clamp coil.....	6-28
6.27 - Centring of the clamp coil on the pipe.....	6-28
6.28 - Fastening of the rope to the handle bars.....	6-29

6.29 - Opening of the clamp coil through the OPEN pedal.....	6-30
6.30 - Complete opening of the clamp coil	6-30
6.31 - Centring of the clamp coil on the pipe	6-31
6.32 - Moving down of the clamp coil onto the pipe	6-31
6.33 - Closing of the clamp coil for its moving down onto the pipe.....	6-32
6.34 - Automatic closing of the clamp coil	6-32
6.35 - Complete closing of the clamp coil through the CLOSE pedal	6-33
6.36 - Partial opening of the clamp coil by hooking arms kept lifted.....	6-33
6.37 - pening of the clamp coil through the OPEN pedal	6-34
6.38 - Release of the bar on the opposite shoulder	6-34
6.39 - Use of the OPEN pedal for the clamp coil complete opening	6-35
6.40 - Positioning of the external ring coils onto the pipe	6-35
6.41 - Positioning of the internal ring coils onto the pipe	6-36
6.42 - Command and control	6-38
6.43 - Remote control.....	6-40
6.44 - Compressed air system (Optional).....	6-42
6.45 - 120 Vac auxiliary generator (Optional).....	6-43
6.46 - Battery charger (Optional).....	6-44
6.47 - Setting menu of the LOGGER (Optional) (flow diagram)	6-45
6.48 - Visualization of the heating cycle records	6-46
6.49 - Visualization of the alarm records	6-47
6.50 - Visualization of the "EVENT" records.....	6-47
6.51 - Download the logger's data file (Optional)	6-48

CHAPTER 7

7.1 - Check and possibly clean the air intake grate.....	7-3
7.2 - Check and possibly clean the air exhaust grate.....	7-4
7.3 - Check the correct execution of the automatic test in the generator power supply phase	7-4
7.4 - Clean the commands and controls situated on the command and control panel.....	7-5
7.5 - Check the correct operation of the exhaust valve, and possibly lubricate the relevant fastening pin	7-6
7.6 - Check the engine oil correct level and top it up, if necessary	7-7
7.7 - Check the engine coolant correct level and top it up, if necessary	7-8
7.8 - Check and possibly replace the air filter cartridge of the compressed air system (Optional).....	7-9
7.9 - Check and possibly clean the air filter desiccator of the compressed air system (Optional)	7-10
7.10 - Check the power connectors, situated on the generator, on the coil and on the power cables between generator and coil.....	7-12
7.11 - Generally check the wear of the insulating material of the generator internal power cables and the tightening of the power wiring clamping screws and nuts	7-13
7.12 - Electronic cards' replacement (Sheet 1 of 2)	7-15
7.12 - Electronic cards' replacement (Sheet 2 of 2)	7-16
7.13 - Fuses F1, F2, F3, F4, F5 and F8 replacement.....	7-17
7.14 - Fuse F0 replacement	7-18
7.15 - Reset of the automatic breaker "QS1" (Sheet 1 of 2).....	7-19
7.15 - Reset of the automatic breaker "QS1" (Sheet 2 of 2).....	7-20

CHAPTER 8

8.1 - Ground fault switch “QM1”	8-3
8.2 - Ground fault.....	8-7
8.3 - Connectors “J19” and “CN 10” (Sheet 1 of 2)	8-11
8.3 - Connectors “J19” and “CN 10” (Sheet 2 of 2)	8-12
8.4 - Connector of the engine control unit	8-12

Chapter

1

INTRODUCTION

We jointly want to thank you for having preferred **TeSi s.r.l.** and to congratulate you on the choice you made; by purchasing your new **Induction Heating Generator IHG 120CU** you provided yourself with a product characterized by excellent performances, high efficiency and reliability.

1.1 INDUCTION HEATING GENERATOR IHG 120CU IDENTIFICATION DATA

Here following, the Induction Heating Generator IHG 120CU TeSi s.r.l. identification plates (see Figure 1.1), which this manual refers to, are reported:



a. Identification plate applied on the generator

Figure 1.1 - Induction Heating Generator IHG 120CU identification plates
(Sheet 1 of 5)

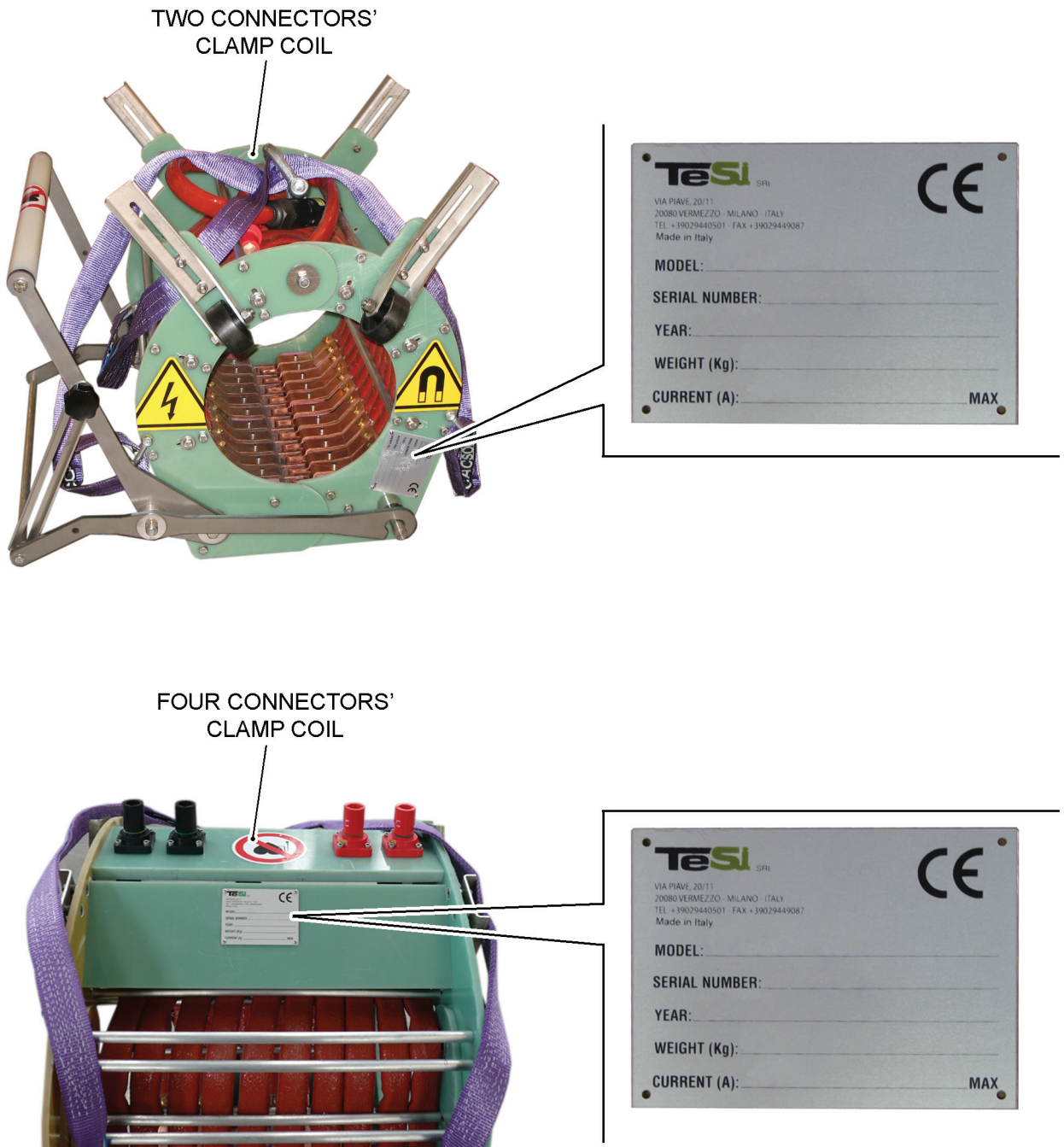

b. Identification plate applied on the standard clamp coil

Figure 1.1 - Induction Heating Generator IHG 120CU identification plates
(Sheet 2 of 5)



c. Identification plate applied on the heavy duty clamp coil

*Figure 1.1 - Induction Heating Generator IHG 120CU identification plates
(Sheet 3 of 5)*

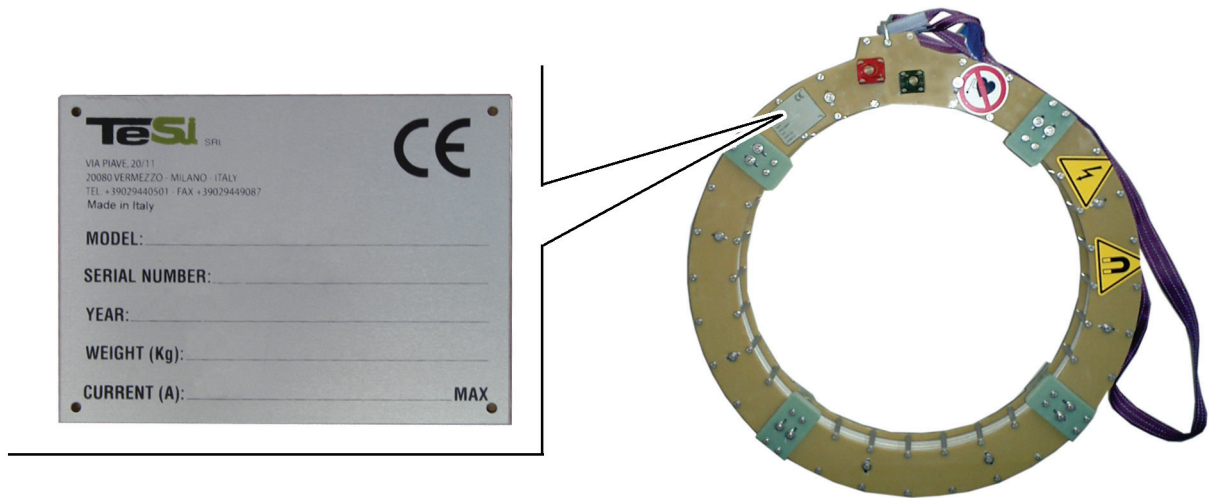

d. Identification plate applied on the external ring coil

Figure 1.1 - Induction Heating Generator IHG 120CU identification plates
(Sheet 4 of 5)



e. Identification plate applied on the internal ring coil

Figure 1.1 - Induction Heating Generator IHG 120CU identification plates
(Sheet 5 of 5)

1.2 IDENTIFICATION OF THIS PUBLICATION

The “USE AND MAINTENANCE INSTRUCTIONS” manual is an official document issued by TeSi s.r.l. and represents an integral part of the Induction Heating Generator IHG 120CU. It is countermarked by a publication No., reported on the third coversheet, allowing an easy identification, traceability of the manual itself, as well as any later reference to it.

All the information contained in this manual were updated to its publication date. TeSi s.r.l. have the right to modify without giving any previous notice the contents of this manual and decline any responsibility for the possible errors and/or omissions present inside it.

1.3 JOINED PUBLICATIONS

- Engine manual (OWNERS MANUAL - QSB4.5 AND 6.7 ENGINE);
- Induction Heating Generator IHG 120CU wiring diagrams.

1.4 PURPOSE OF THIS PUBLICATION

This manual, meant for the users of the Induction Heating Generator IHG 120CU, contains all the information required for its handling, its installation, its operation and its maintenance. It moreover supplies the information for the personnel training, facilitates the procedure for ordering spare parts and gives indications about the safety devices and the possible residual risks.

On a careful and rational observance of the rules contained in this manual will depend both the correct operation and the useful lifespan of the Induction Heating Generator, as well as the safeguard and protection of the operator's safety.

It is strongly recommended to carefully read and to strictly observe the directives contained in this publication, which are organized, as far as possible, according with a chronological scheme of use of the Induction Heating Generator IHG 120CU.

This manual represents a useful support for the user and a valid mean for reminding him of all the primary operations to be carried out; anyway, some minimum specific technical knowledge is required for using the Induction Heating Generator IHG 120CU on fully safe conditions.

1.5 USE OF THIS MANUAL



NOTE

This manual must be carefully preserved for the whole lifespan of the Induction Heating Generator IHG 120CU.





Should the Induction Heating Generator IHG 120CU be sold, the manual shall be delivered to the new owner together with the generator itself.

The manual is subdivided into two parts; the first part, whose pages are numbered in Roman numerals, consists of the Title Page, the List of the valid pages, the Additions' and Variants' Record and the Table of Contents. The Table of Contents allows to exactly locate the pages containing the topic you are interested in.

The second part, whose pages are numbered in Arabic numerals, is articulated in such a way to supply the user with the necessary indications for operating by fully observing the safety rules in all the installation, setup, use and maintenance phases of the Induction Heating Generator IHG 120CU.

Within the text, some “**symbols**” are used, in order to both highlight and visually distinguish the importance of the different types of information.

Graphic representation of the symbols and relevant meaning:

	NOTE Indicates important complementary information.
	CAUTION The inobservance of the relevant indications can cause even irreparable damages to the Induction Heating Generator IHG 120CU.
	WARNING Highlights any situation possibly dangerous for people.
	PROHIBITION Indicates the prohibition of carrying out actions, procedures, etc.. The inobservance of such a prohibition can cause even irreparable damages to the Induction Heating Generator IHG 120CU, seriously damage the environment or create dangerous situations for people.

The manual, together with the relevant enclosures and integrations, must be kept with the utmost care and be always complete, integral and legible in every part, for being preserved jointly with the Induction Heating Generator IHG 120CU, up to the final elimination of this last one.

Should the manual be lost, a duplicate shall be immediately got by contacting TeSi s.r.l.. Should the transfer printings originally applied on the Induction Heating Generator IHG 120CU be either lost, damaged, or should they result to be even only partially incomprehensible, they shall be promptly replaced.

1.6 REVISION

Should the product be modified, **TeSi s.r.l.** are exonerated from updating previous products or from revising previous manuals, exception made for exceptional cases.

This can lead to some inadequacy of the old manuals, and, therefore, the user can ask for the last revision of the manual itself or for any technical information by directly contacting **TeSi s.r.l.**

The revisions which **TeSi s.r.l.** will possibly transmit to the owner of the Induction Heating Generator IHG 120CU shall be annexed to this manual.

TeSi s.r.l. will be glad to accept any possible suggestions made by the user, purposed to improve the manual, as well as your possible communication about any property change, in case of sale of the Induction Heating Generator IHG 120CU plant to a new owner.

1.7 CONVENTIONS FOR DEFINING THE ORIENTATION

In order to facilitate the comprehension of this manual, here following the conventions for defining the orientation are reported.

The definitions used for identifying the displacement of the Induction Heating Generator IHG 120CU components include the following terms:

- front;
- rear;
- right;
- left.

The “front” part is that where the command and control panel is located, while the “rear” part is that opposite to it.

The “right” and “left” sides are referred to an operator positioned in front of the command and control panel, and looking toward it.

1.8 GLOSSARY AND ABBREVIATIONS

In this paragraph, a list containing not common terms, or terms anyway used with a meaning different from the common one, as well as the abbreviations and the units of measure used in this text, are supplied.

1.8.1 GLOSSARY

The 98/37/CE Machinery Directive (Annex I, 1.1.1.) means by:

- DANGEROUS AREA - an area inside and/or near the machine, in which the presence of an exposed person represents a risk for the safety and the health of the person himself;
- EXPOSED PERSON - any person situated either fully or partially in a dangerous area;
- OPERATOR - a person charged with the task of installing, operating, setting, carrying out the maintenance, cleaning, repairing and transporting the machine.

MAN-MACHINE INTERACTION - any situation in which an operator interacts with the machine, in any of the operative phases and in any moment of the machine lifespan.

RESIDUAL DANGER - a danger which couldn't be possibly either eliminated or sufficiently reduced in the machine designing phase.

SAFETY COMPONENTS - the components used for protecting the operator, whose faulty or bad operation can prejudice the safety and the health of the exposed persons (for example fixed or mobile protections, electric devices, pneumatic devices, etc.).

1.8.2 ABBREVIATIONS

%	percentage
°C	Celsius degree (centigrade degree)
A	ampere
Ah	ampere-hour
CFM	cubic feet per minute (flow rate)
cosφ	cosine of the phase angle between current and voltage (alternate current)
dB(A)	decibel (noise unit of measure)
etc.	et cetera
ex.	example
gal	gallons
Hz	hertz (cycles per second)
Kg	kilogram
kPa	kilopascal
KW	Kilowatt
Lt	liter
M	meter
m ³	cubic meters (volume)
Max.	Maximum
Min.	Minimum
min	minute
mm	millimeters

No.....number
 PF..... Power Factor (ratio between the active power and the apparent power)
 Pr..... progressive number
 PSI.....pounds per square inches
 rpm revolution per minute
 see..... compare
 V volt
 Vac. alternate current volt
 W..... watt

1.9 SAFETY WARNINGS

1.9.1 GENERAL WARNINGS



WARNING

Carefully read the information reported in Chapter 3 “Safety rules” before carrying out any operation on the Induction Heating Generator IHG 120CU.

You are moreover here reminded that:

- The Induction Heating Generator IHG 120CU must not be used, neither any intervention can be carried out on it, without having previously read and fully understood this manual in every part;
- It is forbidden to use the Induction Heating Generator IHG 120CU for any use, other than those indicated in the manual, and **TeSi s.r.l.** can't be held as being responsible for failures, inconveniences and accidents due to lack of knowledge of what reported in this manual;
- It is forbidden to either tamper with the equipments treated in the instruction manual, to alter or to modify them, even partially, in particular as far as the protection guards and the doors situated on the generator and foreseen for granting people safety, are concerned;
- It is forbidden either to operate in any different way from the indicated one or to neglect the operations purposed for granting a full safety.



NOTE

It must be considered that the rules contained in this manual can't possibly foresee some particular situations, which could occur during the different working phases.

1.9.2 PERSONNEL QUALIFICATION

All the operations relevant to the Induction Heating Generator IHG 120CU, from the maintenance up to its final elimination, require the presence of personnel with an adequate training level, in order to reduce to the minimum the risks due to a lack of professional specialization.

For this purpose, as far as the qualification of the personnel to be employed is concerned, reference shall be made to the here following enlisted indications:

- USER: is a person trained for using the Induction Heating Generator IHG 120CU, such to grant a good knowledge of the procedures both on usual and on emergency conditions.
- MECHANICAL MAINTAINER: he must have either a mechanical or an electro-technical qualification, perfectly know the contents of this manual and be adequately trained on the safety rules, in order to be authorized to operate on the Induction Heating Generator IHG 120CU.
- ELECTRIC MAINTAINER: he must have either an electro-technical or an electro-mechanical qualification, perfectly know the contents of this manual and be adequately trained on the safety rules, in order to be authorized to operate on the Induction Heating Generator IHG 120CU.

**PROHIBITION**

Don't employ any personnel having a qualification different from the indicated one.

1.9.3 PERSONAL SAFETY MEANS



When using the Induction Heating Generator IHG 120CU, the operator shall always wear the here following enlisted personal safety means:





- safety shoes;
- protective gloves;
- eyes protection;
- helmet;
- protective ear-guards;
- safety faceplate;
- body protective overalls.

1.9.4 SAFETY TRANSFER PRINTINGS

In order to safeguard the personnel safety, on the Induction Heating Generator IHG 120CU, in the most adequate places and according with the identified risks, some proper safety transfer printings were applied. The following Table 1.1 reports the transfer printings with their meaning and respective position on the Induction Heating Generator IHG 120CU.

Table 1.1 - Safety transfer printings

SYMBOL	DESCRIPTION	POSITION ON THE INDUCTION HEATING GENERATOR IHG
	Sound power level emitted by the generator = 97 dB (A)	On the generator structure, near the command and control panel
	Dangerous electric voltage	<p>On the access door to the power factor correction capacitors</p> <p>On the access door to the alternator, rear part</p> <p>On the left and right sides of the standard clamp coil</p> <p>On the front and rear sides of the heavy duty clamp coil</p> <p>On the front and rear sides of the external ring coil</p> <p>On the front side of the internal ring coil</p>

SYMBOL	DESCRIPTION	POSITION ON THE INDUCTION HEATING GENERATOR IHG
	High magnetic field	<p>On the access door to the power factor correction capacitors</p> <p>On the access door to the alternator, rear part</p> <p>On the left and right sides of the standard clamp coil</p> <p>On the front and rear sides of the heavy duty clamp coil</p> <p>On the front and rear sides of the external ring coil</p> <p>On the front side of the internal ring coil</p>
	Hot surfaces	<p>On the access doors to the engine compartment and to the alternator</p> <p>On the access door to the power factor correction capacitors</p> <p>On the generator right side, over the air exhaust grate</p>
	Moving mechanisms	<p>On the access doors to the engine compartment and to the alternator</p>
	Danger for people with a pacemaker	<p>On the access door to the power factor correction capacitors</p> <p>On the access door to the alternator, rear part</p> <p>On the opening/closing handle of the standard clamp coil</p> <p>On the front and rear sides of the heavy duty clamp coil</p> <p>On the front and rear sides of the external ring coil</p> <p>On the front side of the internal ring coil</p>
	Grounding point	<p>On the front left rail of the generator (one point)</p>

SYMBOL	DESCRIPTION	POSITION ON THE INDUCTION HEATING GENERATOR IHG
	Obligation to use lifting hooks with adequate hoisting capacity (3 t)	On the four generator plates, near the hoisting holes

	<p>NOTE</p> <p>As far as the safety transfer printings relevant to the personal safety means are concerned, observe those foreseen by the yard and/or by the relevant rules in force in the country where the Induction Heating Generator IHG 120CU is used.</p>
---	---

1.10 PERSONNEL TRAINING

The training of the personnel using and carrying out the maintenance interventions on the Induction Heating Generator IHG 120CU is quite simple and is imparted at machine delivery.

All the necessary information is anyway supplied in this manual.

As described in this manual, the operator must execute some normal checks before setting the Induction Heating Generator IHG 120CU into operation.

When the Induction Heating Generator IHG 120CU is operating, the operator must keep the instruments situated on the command and control panel under control and, if necessary, intervene on the controls, if some malfunctions are noticed, or, anyway, he must know how to intervene in case of an emergency.

At the end of the working day, the operator must carry out some other simple checks, purposed to verify the correct operation of the Induction Heating Generator IHG 120CU.

Besides, it is very important that the operator is in a position to intervene for carrying out the routine maintenance interventions.

All these operations will be easily realized after having got the instructions given at the plant delivery and after having carefully read this manual.

1.11 CUSTOMER SERVICE

After having tested the **Induction Heating Generator IHG 120CU**, **TeSi s.r.l.** issue a certificate, by which they engage themselves to grant that the Induction Heating Generator IHG 120CU fully complies both with the specifications and with the stated characteristics.

The warranty period is of **12 (twelve) months** since delivery (the Delivery Note date will be taken for reference), exception made for the normal wearing parts, and only foresees the cost-free replacement of defective elements, when an anomaly due to any defects of materials, machining or assembly errors is ascertained.

The replaced parts keep being a property of **TeSi s.r.l.** and must be sent back to their factory within 30 days since reception of the new material; shouldn't the replaced parts be returned within that term, **TeSi s.r.l.** will provide to regularly invoice the new parts. **TeSi s.r.l.** reserve to themselves the right of requesting that the Induction

Heating Generator IHG 120CU, or a part of it, is transferred for repair to their own factory or to other factories of their choice, keeping the relevant transport costs charged to the Customer, and without that this last one can oppose to the machine getting transferred to the seat or advance any damages' compensation.

**NOTE**

The over mentioned warranty period will be valid, only provided that there aren't any different conditions reported on the purchase agreement of the Induction Heating Generator IHG 120CU.

The disassembly and reassembly expenses, as well as those relevant to the transport and packaging of the parts to be replaced in warranty, will be charged to the Customer.

Besides, if not differently specified in the purchase agreement, the journey costs, inclusive of the travelling hours, as well as of the logistic expenses of the **TeSi s.r.l.** personnel carrying out the assistance intervention on warranty terms, will be charged to the plant user.

The denunciation of the defects and the relevant request of intervention shall be made in writing by the user directly to **TeSi s.r.l.** within a term of **8 days** from their manifestation.

The warranty legally ceases when:

- the customer didn't observe the payment contract obligations;
- the purchaser eliminates, deletes or modifies the digits or the data or the marks directly reported on the Induction Heating Generator IHG 120CU, i.e., on the plates or on the identification plates applied to the **TeSi s.r.l.** product;
- the Induction Heating Generator IHG 120CU is used in a way not complying with the **TeSi s.r.l.**'s indications, and, therefore, in case of:
 - manoeuvring errors;
 - overloads;
 - use of lubricants different from the prescribed ones;
 - mounting of not original spares;
 - inobservance of the maintenance rules;
 - non-filling of the Maintenance Service Tables (see Chapter 9).

In none of the over mentioned cases the Customer can exact either the contract cancellation or a compensation for damages.

1.11.1 AFTER-SALES TECHNICAL SERVICE

For any kind of intervention, the **TeSi s.r.l.** "After-Sales Technical Service" is at their Customers' full disposal. Both qualified personnel and specific equipments are available for overhaul and/or repair interventions. The **TeSi s.r.l.** "After-Sales Technical Service" is always available for supplying explanations and advices, in order to allow you getting the best performances from your **Induction Heating Generator IHG 120CU**. In case of a failure on the Induction Heating Generator IHG 120CU, **TeSi s.r.l.** suggest to consult, first of all, Chapter 8 of this manual, which is relevant to the problems' solution, in order to identify the existing possible interventions to be carried out by your own personnel, without having to ask for the help of the **TeSi s.r.l.** "After-Sales Technical Service". After having consulted Chapter 8, it could anyway still be necessary to ask for the intervention of the **TeSi s.r.l.** "After-Sales Technical Service" technicians.

The intervention request shall be formulated to **TeSi s.r.l.** by using either the references here following reported, or those present on the identification plate fastened to the Induction Heating Generator IHG 120CU:

TeSi s.r.l.
Via Piave, 20/11
20080 Vermezzo, Milano, Italy

Phone..... **+39 02 9440501**
Fax **+39 02 9449087**
Internet web site **www.tesigroup.com**

E-Mail:

- **General information** **info@tesigroup.com**
- **Customer technical assistance**..... **support@tesigroup.com**
- **Sales** **sales@tesigroup.com**

The intervention request procedure must be the following one:

- 1) Contact **TeSi s.r.l.** either by phone or through E-Mail, specifying the Induction Heating Generator IHG 120CU data present on the identification plate and then, with the help of a technician, check the possibility of solving the problem directly on the phone.
- 2) If a solution can't be found by phone or through an E-Mail, send a fax or an E-Mail in order to request an intervention, specifying all the data both relevant to the Induction Heating Generator IHG 120CU and to the owner and place where the generator itself is installed.
- 3) Wait for a call from the "After-Sales Technical Service", to make arrangements for defining the service supply modalities.

1.11.2 SPARE PARTS

The parts to be possibly replaced must be " TeSi ORIGINAL SPARE PARTS", to be purchased at our central store.

Using not original spare parts not only causes the warranty loss, but also exonerates TeSi s.r.l. from any responsibility.

Chapter

2

GENERAL TECHNICAL INFORMATION

2.1 FOREWORD

The Induction Heating Generator IHG 120CU, this manual refers to, allows the heat transmission without any physical contact between the heat source and the metal part to be heated.

The Induction Heating Generator IHG 120CU is used in the following appliances:

- heating of the pipes before the welding process;
- heating for the laying of thermo-shrinking sleeves for anti-corrosive protection of welded joints.

As already previously mentioned, the induction heating can heat the materials at a speed which is scarcely imaginable if compared with the traditional systems (flame or resistance heating), a punctual accuracy and a high efficiency, without any contact with the surface to be heated.

2.1.1 USE DESTINATION

The Induction Heating Generator IHG 120CU is meant for an industrial use.

2.1.2 OPERATOR

No particular technical knowledge is required for using the Induction Heating Generator IHG 120CU. A careful reading of this manual will be sufficient; anyway, it is here reminded that both the experience and a good knowledge of the product represent a quite important factor.

2.1.3 WORK ENVIRONMENT

	<p>PROHIBITION Both positioning and using the Induction Heating Generator IHG 120CU in potentially explosive environments are forbidden.</p>
---	---

The Induction Heating Generator IHG 120CU can operate in any work environment in the yard activity field, exception made for those explosive environments, in which an explosion-proof protection is required.

	<p>CAUTION The Induction Heating Generator IHG 120CU can operate on very steep slopes, up to a maximum of 40° (see Figure 2.1). For mobile use on very sloping terrains, possibly place the Induction Heating Generator IHG 120CU crosswise with respect to the vehicle used for its transport.</p>
---	--

2.1.4 ENVIRONMENTAL REQUIREMENTS

The Induction Heating Generator IHG 120CU must be used by presence of the following environmental conditions:

- Maximum temperature + 45 °C
- Minimum temperature - 15 °C
- Relative humidity 85%

	<p>CAUTION Use a purposed antifreeze for the engine fuel, if temperatures are lower than - 5 °C.</p>
---	---

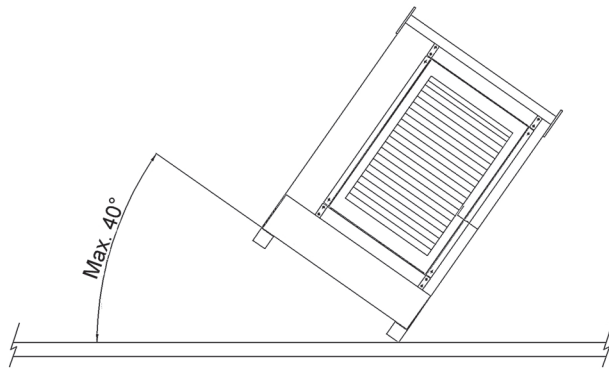

a. Front side max longitudinal gradient

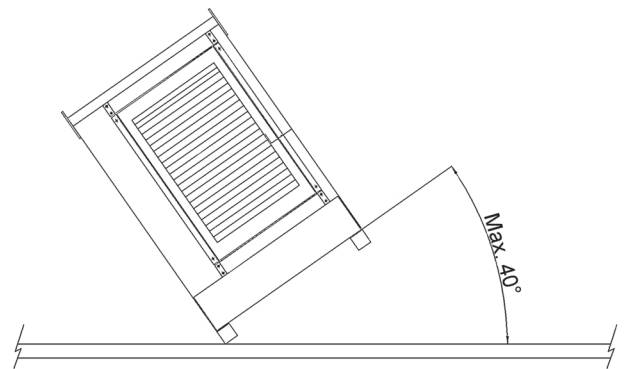

b. Rear side max longitudinal gradient

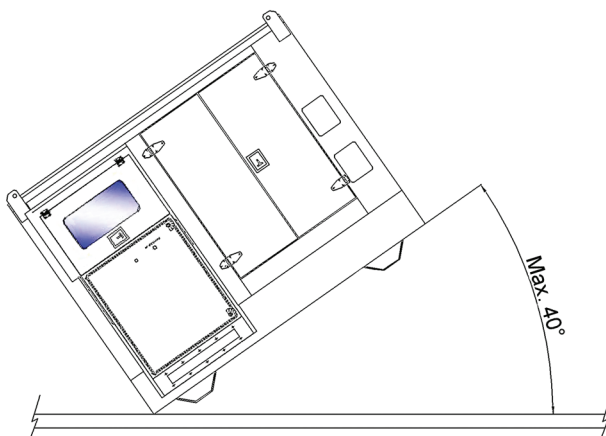

c. Left side max transversal gradient

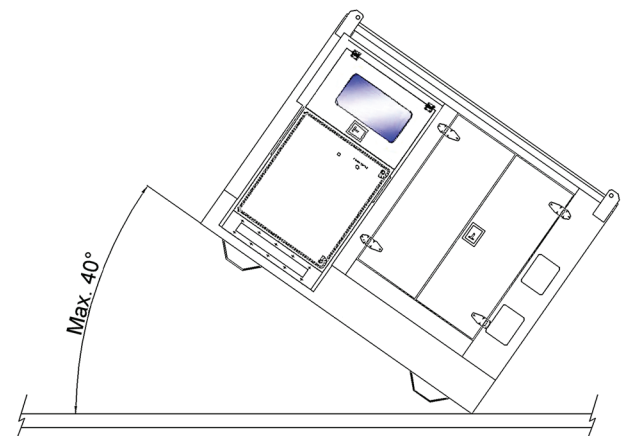

d. Right side max transversal gradient

Figure 2.1 - Max longitudinal and transversal gradients when using the Induction Heating Generator IHG 120CU

The Induction Heating Generator IHG 120CU isn't equipped with any devices for illuminating the working area, as, being usually employed in yards, and consequently in open air, no artificial illumination was held for necessary, even if required by the specifications in force.

**NOTE**

Should the Induction Heating Generator IHG 120CU be used in indoor ambiances, it is recommended to install it in an adequately illuminated area, according with the relevant specifications in force.

**NOTE**

Should the Induction Heating Generator IHG 120CU be used in a scarcely illuminated ambience and/or at night in a yard and consequently in open air, get installed near the same one some adequate artificial illumination devices.

**WARNING**

Should the Induction Heating Generator IHG 120CU be used in indoor ambiances or by scarce ventilation conditions, provide to realize an adequate intake of the exhaust gases.

2.1.5 NOISE EMISSION

The sound power level granted by the Induction Heating Generator IHG 120CU (power 150 kW) is of 97 dB.

**NOTE**

The granted sound power level isn't the noise level which the operator appointed to the Induction Heating Generator IHG 120CU is exposed to, value which must be measured in the yard, according with the law directives. Such value, even if relevant to the only Induction Heating Generator IHG 120CU, can be extrapolated from the measurements realized for calculating the LwA, according with the directive 2005-88-CE.

The acoustic pressure level measured in normal working conditions (work duty cycle 50%) at 1 m of distance and at 1.4 m of height from the ground on the whole perimeter of the Induction Heating Generator IHG 120CU is either equal to or lower than 84 dB (A).

The indicated level is that of pondered instantaneous acoustic pressure during the Induction Heating Generator IHG 120CU power using peaks. The daily or weekly exposure of the workers must be anyway determined, as previously said, in the real use conditions and generally results to be lower than the previously indicated values. Anyway, the use of ear protection-guards is recommended.

2.2 GENERAL DESCRIPTION

The Induction Heating Generator IHG 120CU (see Figure 2.2), consists of four main components, as here following indicated:

- generator (a/1);
- coil (c);
- remote control (b/2);
- power cables (d/7).

The coil (c), according with the requested appliance, can be of four types:

- standard clamp coil (c/3);
- pair of external ring coils (c/4);
- pair of internal ring coils (c/5).
- heavy duty clamp coil (c/6).



a. Generator



b. Remote control

LEGEND

- 1 - Generator
- 2 - Remote control

*Figure 2.2 - Induction Heating Generator IHG 120CU configuration
(Sheet 1 of 2)*

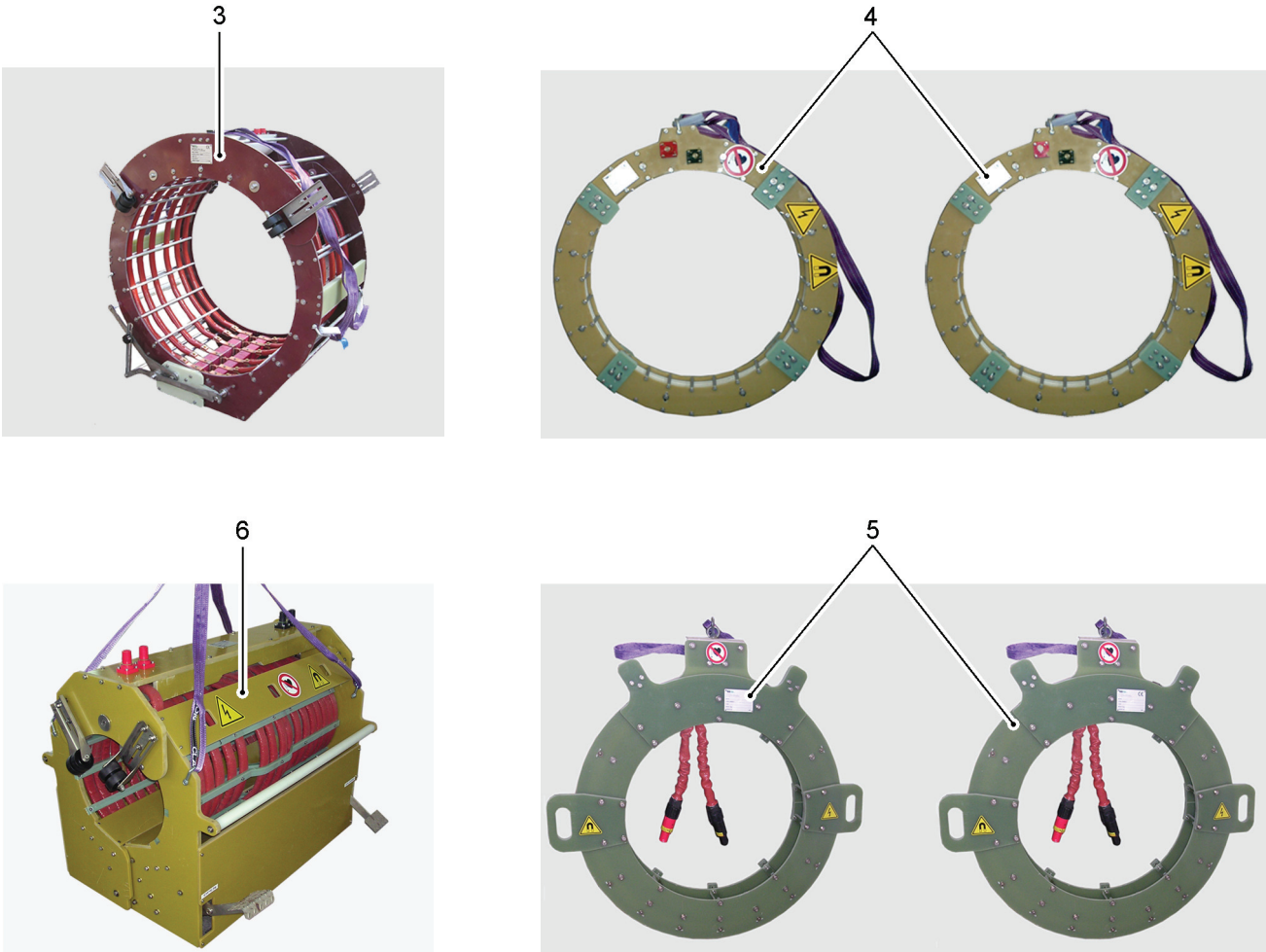

c. Coil (Standard clamp coil, heavy duty clamp coil, external ring coil and internal ring coil)

LEGEND

- 3 - Standard clamp coil
- 4 - Pair of external ring coils
- 5 - Pair of internal ring coils
- 6 - Heavy duty clamp coil
- 7 - Power cables



d. Power cables

Figure 2.2 - Induction Heating Generator IHG 120CU configuration
(Sheet 2 of 2)

2.2.1 GENERATOR

The generator (see Figure 2.3), whose structure is realized in a sturdy metal carpentry, houses it its inside the following main components:

- engine (11);
- batteries;
- air filter (10);
- fuel tank (17);
- generator alternator (30);
- air compressor (38) (optional);
- 120 Vac auxiliary alternator (16) (optional).

On the other hand, in the external front part of the generator structure, the following components are housed:

- command and control panel (2);
- power connectors (22);
- capacitor battery (21);
- battery charger section (27) (optional);
- 120 Vac electric sockets section (29) (optional).

In the front and rear parts, it is possible to notice the doors (4) and (35), which respectively allow to accede to the engine (11) and to the generator alternator (30) for carrying out checks and maintenance interventions.

The access doors (4), are equipped with a handle (7) for opening and closing the same ones; on closing, the over mentioned doors can be locked by means of a purposed padlock (supplied by TeSi s.r.l.).

The opening and closing of the access door (35) to the generator alternator (30) by turning the fastening screws (36) and washers (37).

In the front part, there is the access door (6) which permits accessing to the battery charger section (27) (optional) and to the 120 Vac electric sockets section (29) (optional).

A further access door (8) to the filler cap of the engine fuel tank (17) is located below the access door (6).

On the structure left side, there is the air intake grate (26), having the purpose of facilitating the cooling down inside the structure itself during the engine operation.

Besides, in the right side of the structure, an air exhaust grate (47) of the engine coolant radiator (14) is present.

The grates (26) and (47) are fixed to the structure by means of the screws (23) and relevant washers (24).

In the upper part, the exhaust pipe terminal (34) of the exhaust gases, equipped with a closing lid (33), is situated.

In the front part, a transparent hatch (1), hinged to the upper structure and having a compass-opening, protects the components situated on the command and control panel (2) against any possible bumps and against dust infiltrations. The hatch is equipped with one gas springs for keeping it locked in the maximum opening phase.

The opening and the closing of the transparent hatch (1) is performed by means of the handle (3); on closure, the over mentioned hatch can be locked by means of a purposed padlock (supplied by TeSi s.r.l.).

Under the transparent hatch (1), a door (25) hinged to the structure and provided with lockers, closes the capacitor battery (21) housing compartment.

In upper position, four lifting plates (5) for hoisting the machine, welded to the structure respective corners and provided with suitable holes, allow to handle the generator.

In the lower part, on the other hand, four rails (9), which are, in fact, the stands of the generator itself, can be also used for handling the same one.

LEGEND

- 1 - Transparent hatch
- 2 - Command and control panel
- 3 - Handle
- 4 - Access door (front and rear parts)
- 5 - Lifting plate (1 of 4)
- 6 - Access door
- 7 - Handle
- 8 - Access door to the fuel tank filler cap
- 9 - Rail (1 of 4)
- 10 - Engine air filter
- 11 - Engine
- 12 - Exhaust silencer
- 13 - Engine alternator
- 14 - Engine cooling liquid radiator
- 15 - Engine oil filter
- 16 - 120 Vac auxiliary alternator (optional)
- 17 - Fuel tank
- 18 - Starter engine
- 19 - Battery switch
- 20 - Capacitor contactors
- 21 - Capacitor battery
- 22 - Power connectors
- 23 - Screw
- 24 - Washer
- 25 - Door
- 26 - Air intake grate

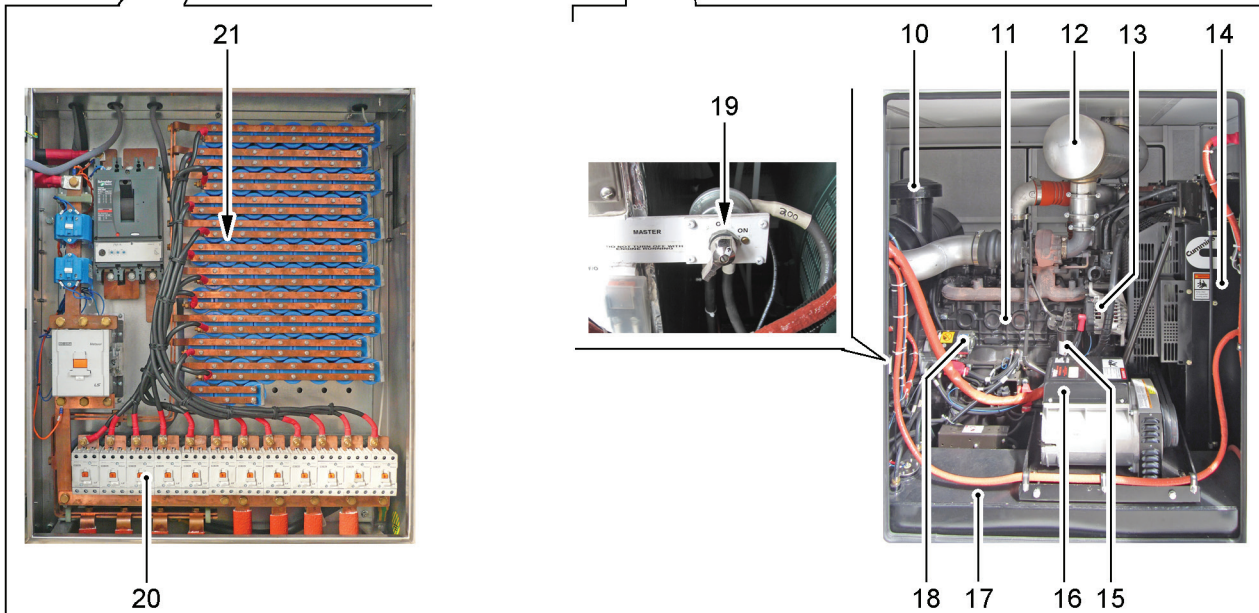
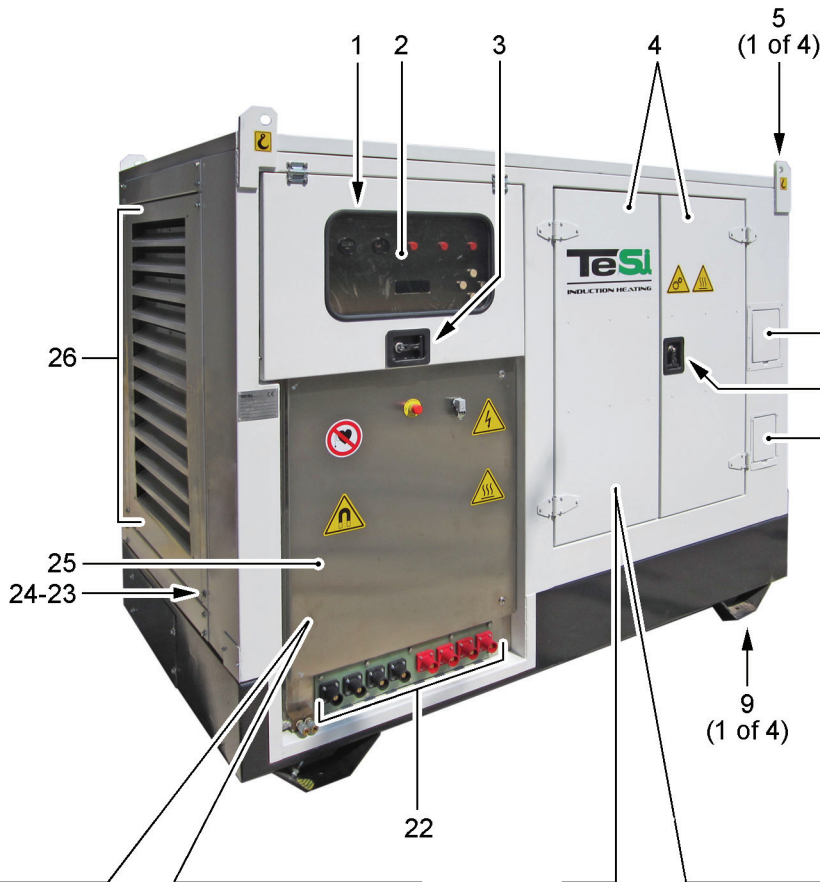

a. Left front view

Figure 2.3 - Displacement of the parts composing the generator
(Sheet 1 of 3)

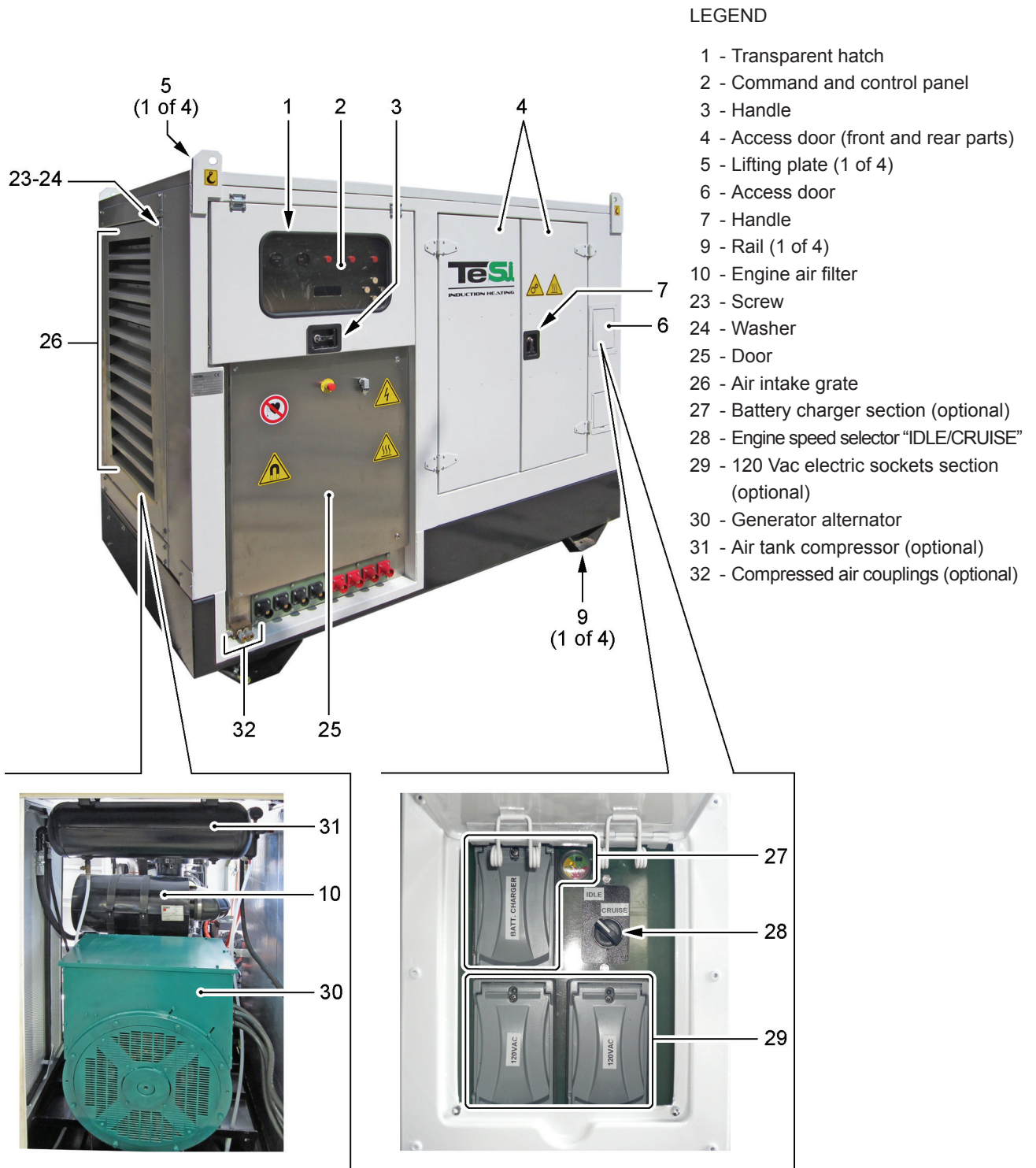
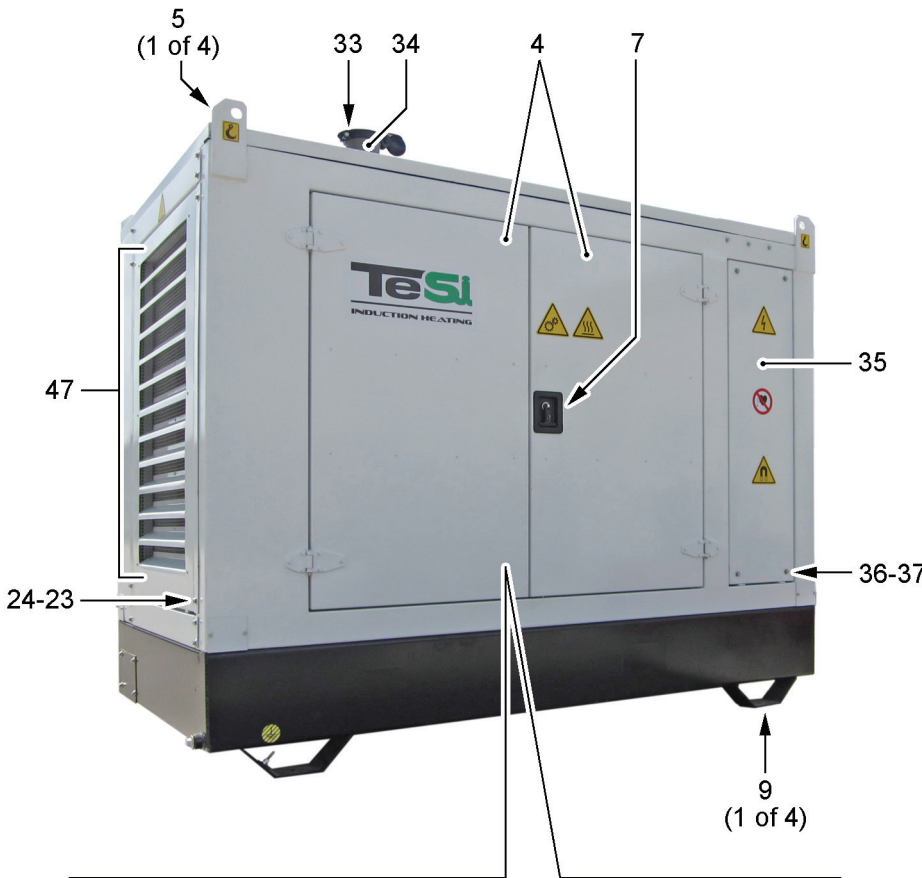
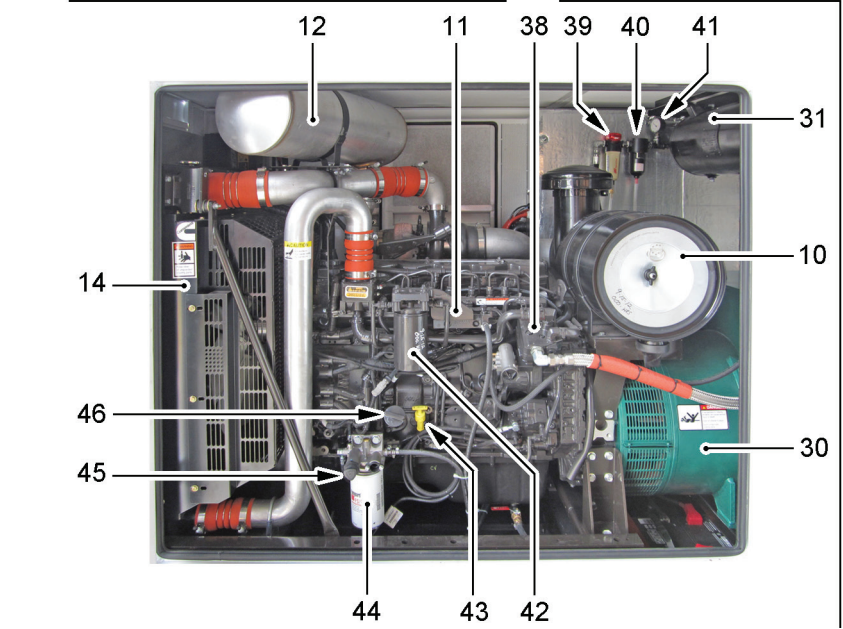

Figure 2.3 - Displacement of the parts composing the generator
(Sheet 2 of 3)

LEGEND



- 4 - Access door (front and rear parts)
- 5 - Lifting plate (1 of 4)
- 7 - Handle
- 9 - Rail (1 of 4)
- 10 - Engine air filter
- 11 - Engine
- 12 - Exhaust silencer
- 14 - Engine cooling liquid radiator
- 23 - Screw
- 24 - Washer
- 30 - Generator alternator
- 31 - Air tank compressor (optional)
- 33 - Closing lid
- 34 - Exhaust pipe terminal
- 35 - Access door (rear part)
- 36 - Screw
- 37 - Washer
- 38 - Air compressor (optional)
- 39 - Air compressor filter (optional)
- 40 - Air compressor desiccator filter (optional)
- 41 - Air compressor pressure gauge (optional)
- 42 - Engine fuel filter
- 43 - Engine oil level dipstick
- 44 - Engine fuel pre-filter
- 45 - Fuel scavenge hand pump
- 46 - Engine oil filler cap
- 47 - Air exhaust grate



c. Right rear view

Figure 2.3 - Displacement of the parts composing the generator
(Sheet 3 of 3)

2.2.1.1 Engine

The CUMMINS manufactured engine (see Figure 2.3/11), model QSB6.7, which the Induction Heating Generator IHG 120CU is equipped with, is a 6 cylinders in-line, common rail injection water-cooled Diesel engine with turbo intercooler, which is used in order to drag the generator alternator (see Figure 2.4).

This engine (see Figure 2.3/11) has such performing characteristics to make its use possible even under extremely heavy conditions, with a minimum maintenance.

**NOTE**

As far as the information relevant to the engine are concerned, reference shall be made to the "Owners Manual - QSB4.5 and 6.7" delivered by TeSi s.r.l. as a Jointed Publication to this manual.

2.2.1.2 Generator alternator

It is the current generator which is dragged, as previously mentioned, by the engine (see Figure 2.3/11).

The power produced by the alternator (see Figure 2.4/1) provides to power supply the coils.

The current produced by the alternator (1) is controlled by the electronic control system, which, in case of anomalies, actuates the proper safety measures (for ex., stop of the heating cycle), and provides to light up the relevant warning lights and to visualize messages on the display; the over mentioned indications are present on the command and control panel (see Figure 2.3/2).

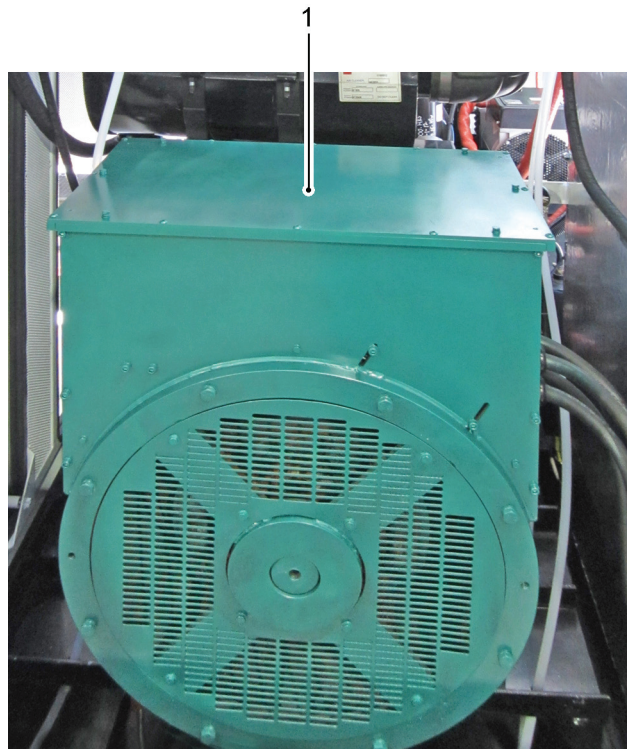
**LEGEND**

1 - Generator alternator

Figure 2.4 - Generator alternator

2.2.1.3 Capacitors

The capacitor battery, present in the generator, allows the power factor correction of the voltage and current produced by the alternator.



WARNING

Pay attention to the capacitor bars, as they aren't insulated.



WARNING

The capacitors may be charged even after the generator was turned off.

The capacitor battery (see Figure 2.5/1) and the twelve capacitors contactors (2) are installed inside the compartment present in the front part of the generator; the compartment is closed by a door (3) hinged to the structure and provided with lockers.

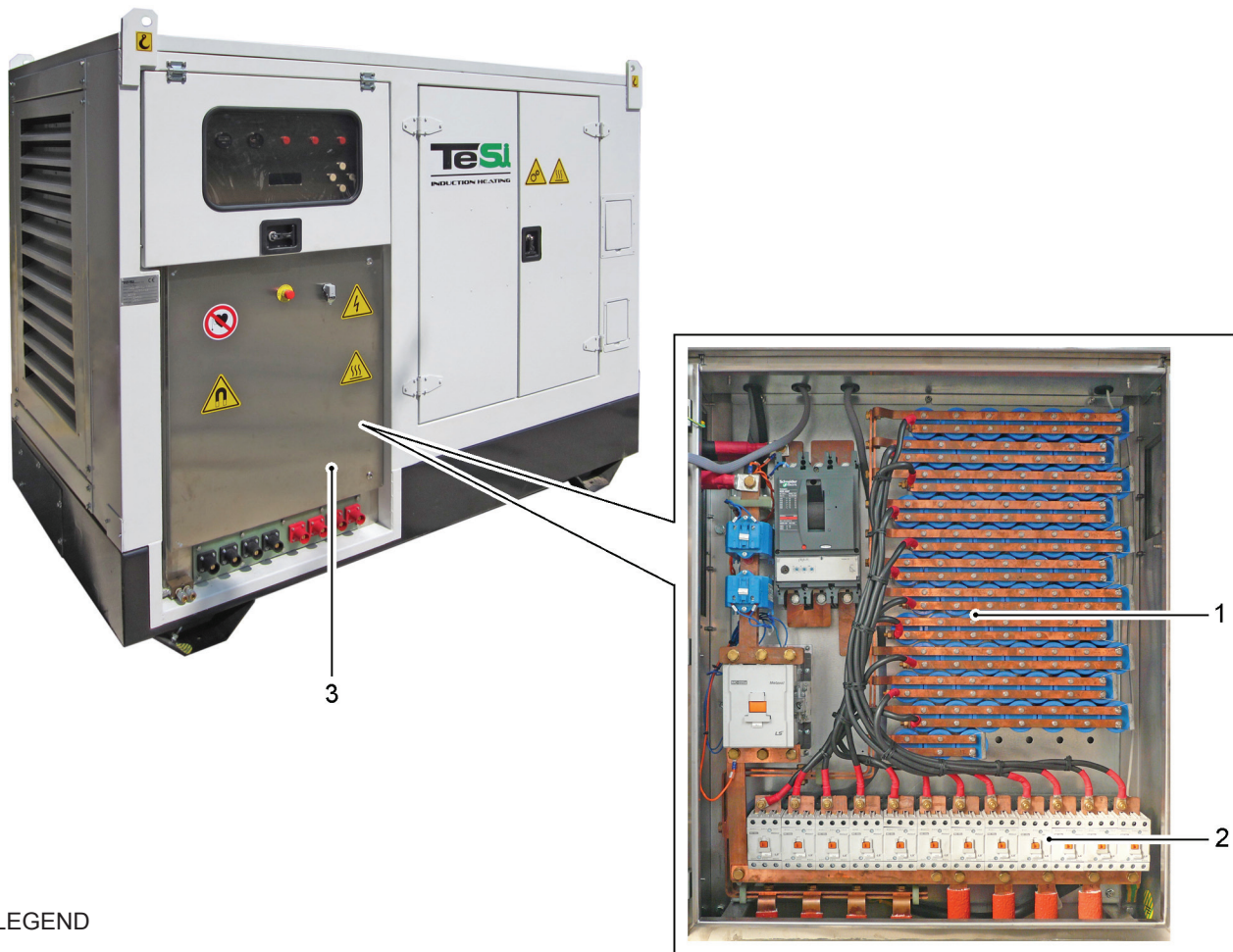

LEGEND

- 1 - Capacitor battery
- 2 - Capacitor contactors
- 3 - Door

Figure 2.5 - Capacitor battery and capacitor contactors

2.2.1.4 Command and control panel

The command and control panel (see Figure 2.6), which is accessible by opening upwards the relevant transparent hatch, allows to carry out all the settings before machine starting, to identify any possible alarm condition and to both actuate and deactivate the operating cycle of the Induction Heating Generator IHG 120CU.

The operating parameters can be visualized on the display (15), which results to be visible even by absence of light, and which is characterized by a good legibility even from quite far distances and grants a regular operation even by extreme temperatures.

On the command and control panel (see Figure 2.6), there is a series of commands and controls, as here following specified:

- Hours meter indicator (1);
- Fuel level indicator (2);
- Engine oil pressure warning light (3);
- Engine high temperature warning light (4);
- Engine alternator fault warning light (5);
- “UP” menu pushbutton (6);
- “ENTER” menu pushbutton (7);
- “DOWN” menu pushbutton (8);
- “ESC” menu pushbutton (9);
- Ignition key (10);
- Remote control connector (11);
- Emergency stop mush-room-head pushbutton (12);
- Heating cycle stop pushbutton (13);
- USB connector (14) (optional);
- Display (15).

	<p>NOTE As far as the detailed description of the commands and controls is concerned, reference shall be made to Paragraph 6.2.</p>
---	--

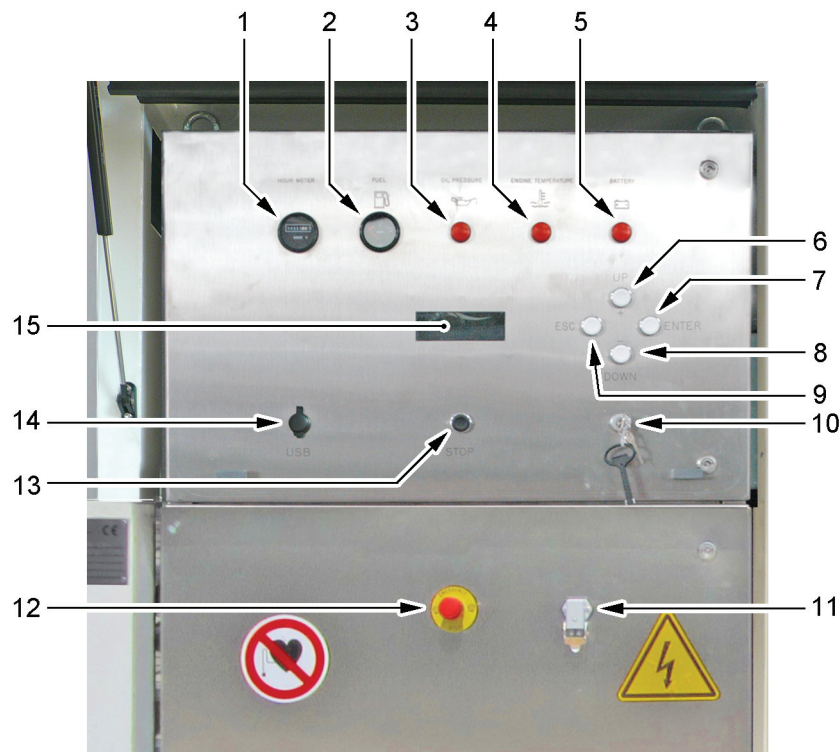

Figure 2.6 - Command and control panel

The electronic board (see Figure 2.7/2), situated inside the structure, and more precisely under the command and control panel (see Figure 2.6), houses all the equipments and the electronic card for operatively controlling both the panel itself and the safety controls.

In detail, in the electronic board the following components can be noticed:

- Display (see Figure 2.7/1);
- CPU control card (2);
- Ground fault switch (4);
- Fuses (3).

**NOTE**

In order to get further information about the electric plant of the Induction Heating Generator IHG 120CU, reference shall be made to the “Wiring Diagrams” delivered by TeSi s.r.l. as a Jointed Publication to this manual.

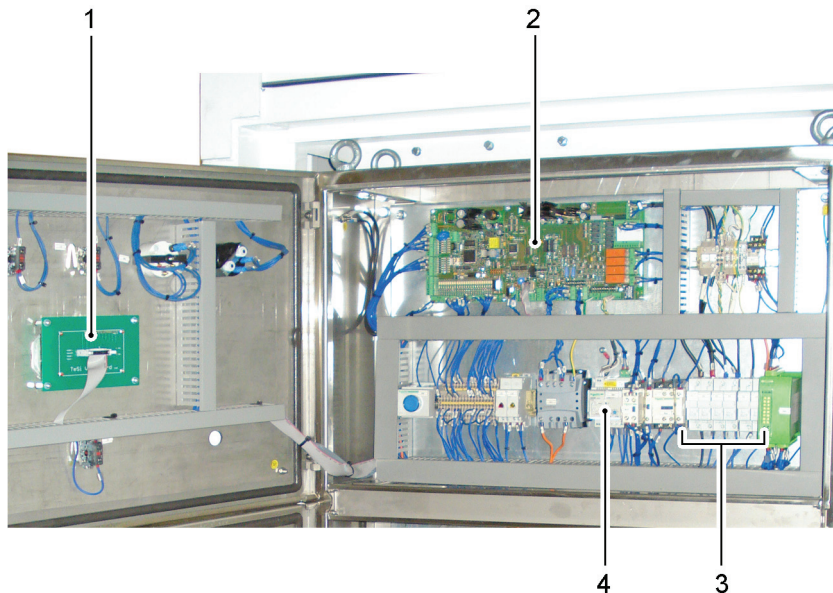
**LEGEND**

- 1 - Display
- 2 - CPU control card
- 3 - Fuses
- 4 - Ground fault switch

Figure 2.7 - Electric board, housing the components representing the control system

2.2.1.5 Output power connectors

On the Induction Heating Generator IHG 120CU front part, under the command and control panel, there are eight power insulated connectors, four of which are red (see Figure 2.8/2) and four black (1), which allow to deliver current to the coils through the relevant power cables realizing the connection between generator and coil.

	<p>PROHIBITION For no reason carry out the disconnection of the power cables during the heating cycle.</p>
---	---

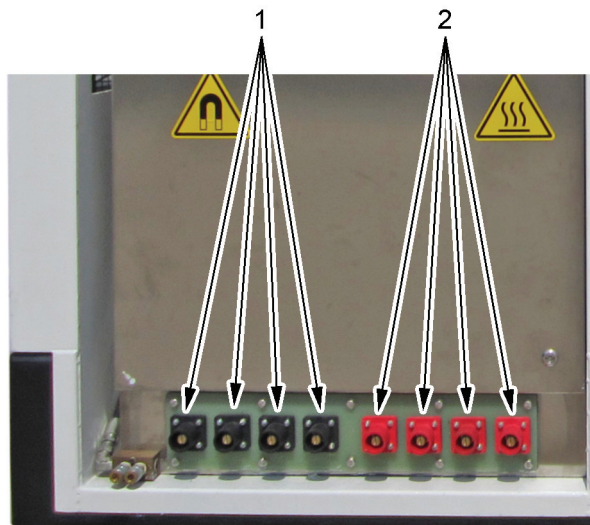

LEGEND

- 1 - Black output power connectors
- 2 - Red output power connectors

Figure 2.8 - Output power connectors, situated on the generator

2.2.1.6 Batteries

The electric plant operates by direct current with a 24V rated voltage delivered by two batteries (see Figure 2.9/4) “sealed” by 12 V, connected in series. The batteries (4), placed inside the engine compartment, provide the power supply for all the control circuits of the generator.

The batteries (4) are housed in an extractable drawer (3), situated outside the generator on the left side, and accessible after removing the screws (1) and relevant washers (2).

	<p>NOTE In order to get further information about the electric plant of the Induction Heating Generator IHG 120CU, reference shall be made to the “Wiring Diagrams” delivered by TeSi s.r.l. as a Joined Publication to this manual.</p>
---	---

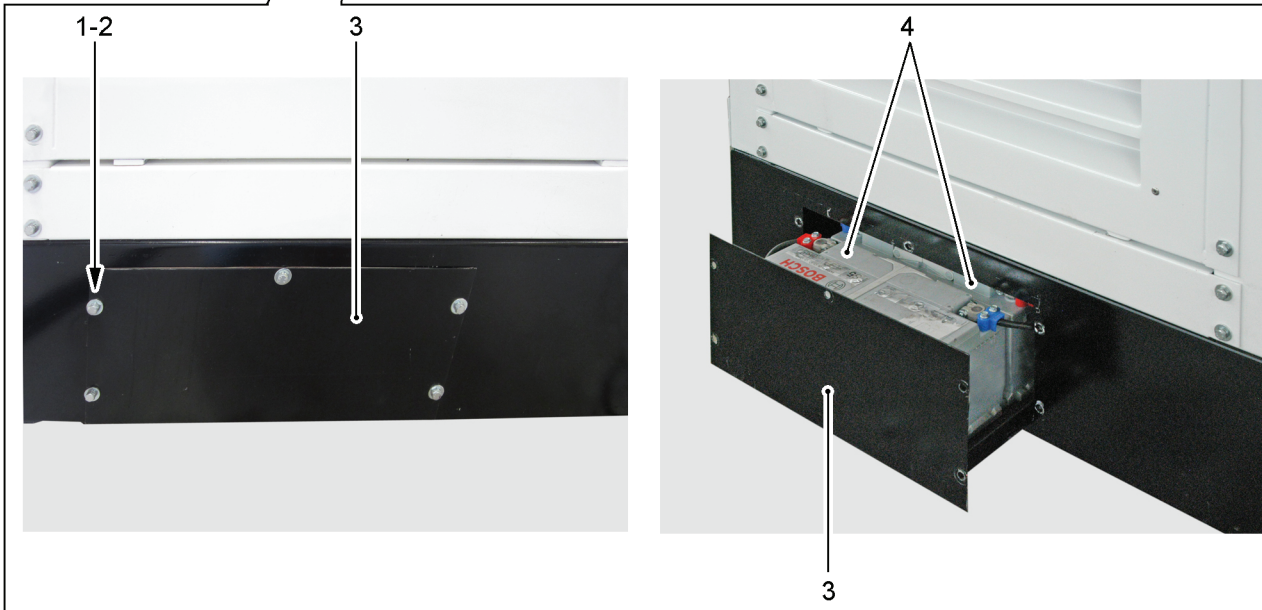

LEGEND

- 1 - Screw
- 2 - Washer
- 3 - Extractable drawer
- 4 - Batteries

Figure 2.9 - Batteries

2.2.2 COILS

The coils were both designed and realized in order to heat the pipe surface before welding and for generating the heating which precedes the laying of protective products against corrosion.

As already previously mentioned, the coils can be subdivided into three categories:

- standard clamp coil (coating) (see Figure 2.10);
- heavy duty clamp coil (coating) (see Figure 2.11);
- pair of external ring coils (before welding) (see Figure 2.12);
- pair of internal ring coils (before welding) (see Figure 2.13).

The over mentioned coils can show different structural characteristics, such as their diameter and their heating length, in order to satisfactorily meet the different requirements of the Customer, but not only, because TeSi s.r.l. can realize modifications to the coils, according with the Technical Specifications supplied by the Customer himself.



PROHIBITION

Never open or remove the coils when the Induction Heating Generator IHG 120CU is in the heating cycle phase.

2.2.2.1 Standard clamp coil

The standard clamp coil (see Figure 2.10) specifically provides to heat the pipes' junction area, before application of the protective products against corrosion. The openable structure is realized in fiberglass.

The main parts composing the standard clamp coil (see Figure 2.10) are the following ones:

- power connectors (1) and (11);
- conductors and inductive turns (10);
- contacts for turns' closure (8).

Externally, on the lower part of the standard clamp coil (see Figure 2.10) structure, a mechanism mainly consisting of a handle (2) and of two hook-levers (9), which, on their turn, get engaged on closing to the relevant pins (7) which are integral to the clamp coil, manually allows to completely open (or close) the standard clamp coil (see Figure 2.10), in such a way that the same one gets wrapped around the pipe on which it is necessary to operate.

On the clamp coil upper part, there are besides four adjustable supports (4), equipped with a wheel (5), purposed for centring the standard clamp coil (see Figure 2.10) on the pipe, when the same one is closed.

Four hooks (6) (two on each side), equipped with proper belts (3), allow not only the properly said handling of the standard clamp coil (see Figure 2.10) when it is closed, but also a fast passage from one junction to the next one by means of simple opening and lifting operations.

a) Power connectors

On the upper part of the standard clamp coil (see Figure 2.10), the two power connectors are situated, one of which is red (1) and the other one black (11), and which allow to power supply the coil itself.

The connection between the over mentioned connectors and those present on the generator, is realized through the purposed power cables.



NOTE

The power connectors situated on the clamp coil can be either two or four, according with the type of coil used.

b) Conductors and inductive turns

Still inside the ring structure of the standard clamp coil (see Figure 2.10), there are the conductors and the inductive turns (10), which are dimensioned in such a way to get the utmost thermal output.

c) Contacts for turns' closure

Internally, in the lower part of the standard clamp coil (see Figure 2.10) structure, there are the contacts for the turns' closure (8), also named blade contacts, which get completely connected only when the clamp coil (see Figure 2.10), is both mechanically and electrically closed.

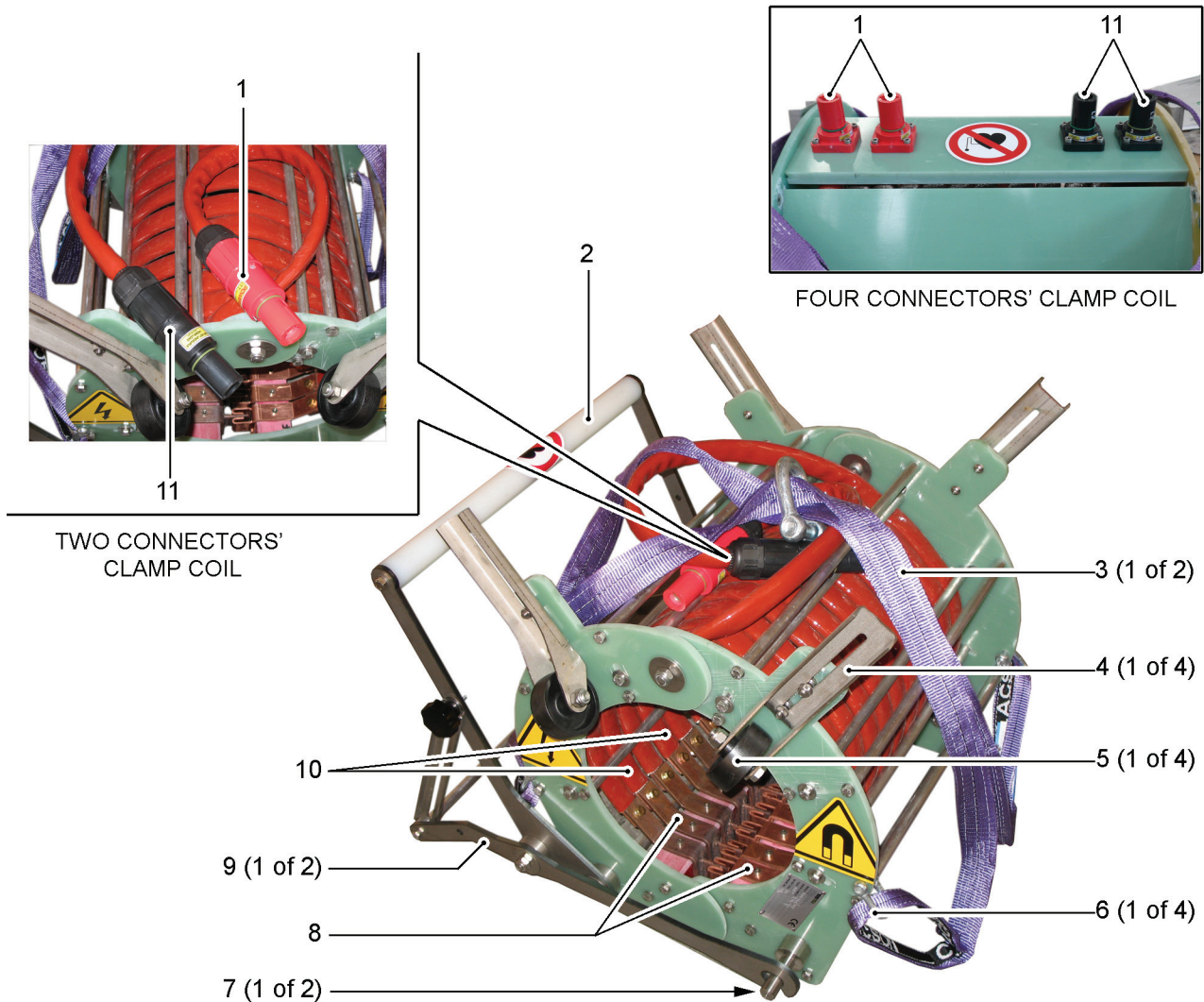

TWO CONNECTORS' CLAMP COIL

FOUR CONNECTORS' CLAMP COIL

LEGEND

- | | |
|---------------------------------|---|
| 1 - Red power connector | 7 - Pin (1 of 2) |
| 2 - Handle | 8 - (Blade) contacts for turns' closure |
| 3 - Belt (1 of 2) | 9 - Hook-lever (1 of 2) |
| 4 - Adjustable support (1 of 4) | 10 - Conductors and inductive turns |
| 5 - Wheel (1 of 4) | 11 - Black power connector |
| 6 - Hook (1 of 4) | |

Figure 2.10 - Standard clamp coil

2.2.2.2 Heavy duty clamp coil

The heavy duty clamp coil (see Figure 2.11) specifically provides to heat the pipes' junction area, before application of the protective products against corrosion. The openable structure is realized in heavy duty fiberglass. The main parts composing the heavy duty clamp coil (see Figure 2.11) are the following ones:

- power connectors (1) and (2);
- conductors and inductive turns (4);
- contacts for turns' closure.

Externally, on the lower part of the heavy duty clamp coil (see Figure 2.11) structure, two control pedals (5) and (7), with relevant mechanism, respectively allow to either open or close the heavy duty clamp coil (see Figure 2.11), in such a way that the same one gets wrapped around the pipe on which it is necessary to operate.

Two handle bars (6), situated on both the sides of the heavy duty clamp coil (see Figure 2.11), facilitate the opening and the closing of the coil on the relevant pipe.

On the clamp coil upper part, there are besides four adjustable supports (9), equipped with four wheels (10), purposed for centring the heavy duty clamp coil (see Figure 2.11) on the pipe, when the same one is closed.

Four hooks (8) (two on each side), equipped with proper belts (3), allow not only the properly said handling of the heavy duty clamp coil (see Figure 2.11) when it is closed, but also a fast passage from one junction to the next one by means of simple opening and lifting operations.

a) Power connectors

On the upper part of the heavy duty clamp coil (see Figure 2.11), the four power connectors are situated, two of which are red (1) and the other two black (2), and which allow to power supply the coil itself.

The connection between the over mentioned connectors and those present on the generator, is realized through the purposed power cables.

b) Conductors and inductive turns

Still inside the ring structure of the heavy duty clamp coil (see Figure 2.11), there are the conductors and the inductive turns (4), which are dimensioned in such a way to get the utmost thermal output.

c) Contacts for turns' closure

Internally, in the lower part of the heavy duty clamp coil (see Figure 2.11) structure, there are the contacts for the turns' closure, also named blade contacts, which get completely connected only when the clamp coil (see Figure 2.11), is both mechanically and electrically closed.

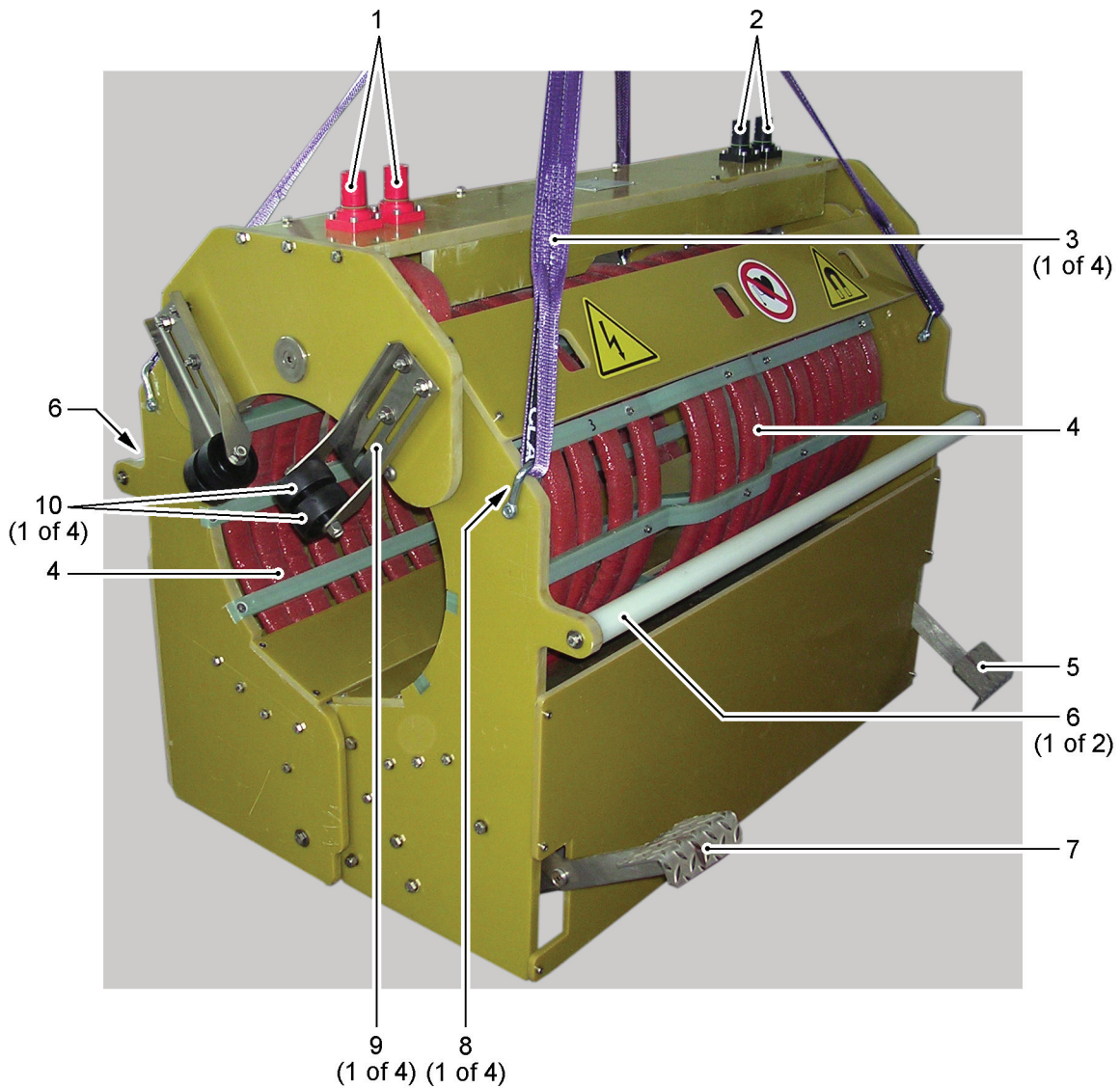

LEGEND

- | | |
|------------------------------------|---------------------------------|
| 1 - Red power connector | 6 - Handle bar (1 of 2) |
| 2 - Black power connector | 7 - Closing control pedal |
| 3 - Belt (1 of 2) | 8 - Hook (1 of 4) |
| 4 - Conductors and inductive turns | 9 - Adjustable support (1 of 4) |
| 5 - Opening control pedal | 10 - Wheel (1 of 4) |

Figure 2.11 - Heavy duty clamp coil

2.2.2.3 Pair of external ring coils

The external ring coil (see Figure 2.12), on the other hand, is used for heating the pipes' ends before the welding process. Its structure is realized in plastic reinforced by fiberglass and aluminium.

Every external ring coil is equipped with two power connectors, one of which is red (1) and the other one black (4), for power supplying the coil itself, and with a hook (2) with belt (3) for its handling.

The delivery consists of a pair of external ring coils, which can be simultaneously connected to the generator.

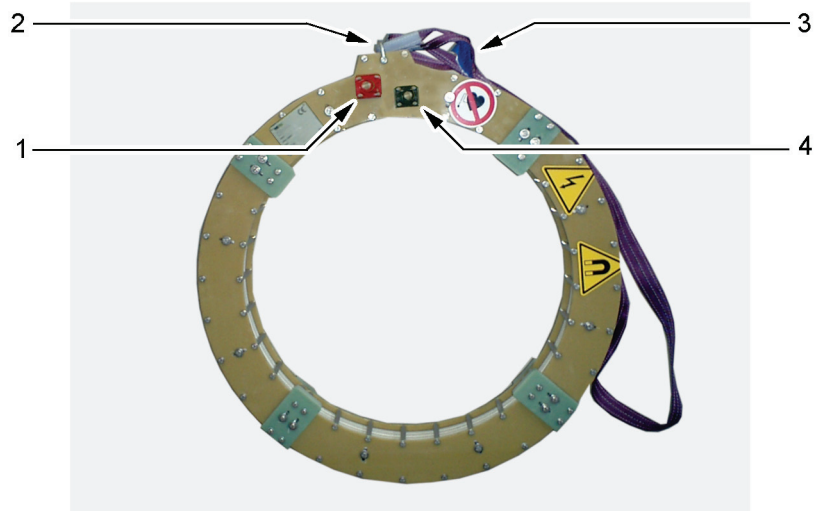

LEGEND

- 1 - Red power connector
- 2 - Hook
- 3 - Belt
- 4 - Black power connector

Figure 2.12 - External ring coil

2.2.2.4 Pair of internal ring coils

The internal ring coil (see Figure 2.13), on the other hand, is used for heating the pipes' ends before the welding process. Its structure is realized in plastic reinforced by fiberglass and aluminium.

Every internal ring coil is equipped with two power connectors, one of which is red (1) and the other one black (4), for power supplying the coil itself, and with a hook (3) with belt (2) for its handling.

The delivery consists of a pair of internal ring coils, which can be simultaneously connected to the generator.

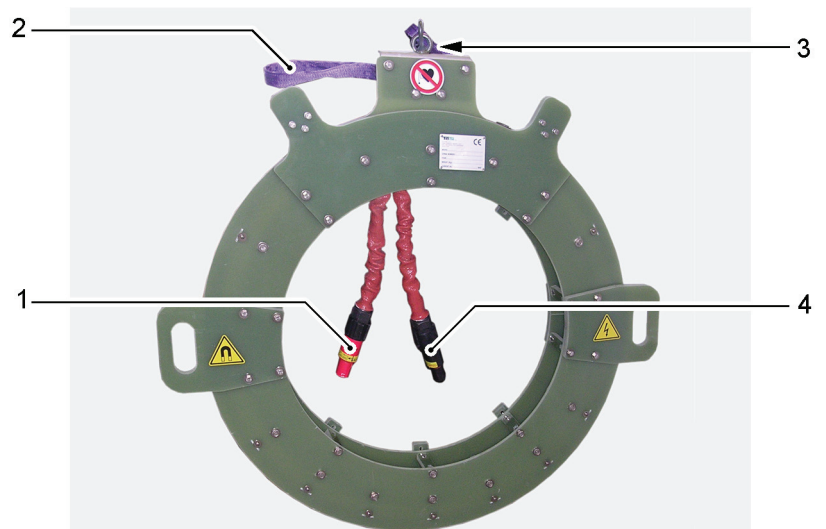

LEGEND

- 1 - Red power connector
- 2 - Belt
- 3 - Hook
- 4 - Black power connector

Figure 2.13 - Internal ring coil

2.2.3 REMOTE CONTROL

The remote control (see Figure 2.14), which can be connected through cable (2) equipped with connector (1) to the corresponding connector situated on the command and control panel, is used by the operator for the usual operation of the Induction Heating Generator IHG 120CU.

Shaped in such a way to be easily held, the remote control (see Figure 2.14) is equipped on its front side with the following commands and controls:

- a pushbutton for starting the heating cycle (START) (3);
- a mushroom-head emergency stop pushbutton (4);
- a heating in progress warning light (5);
- a pushbutton for stopping the heating cycle (STOP) (6).

**NOTE**

The Induction Heating Generator IHG 120CU only operates, provided that the remote control is connected to the purposed connector situated on the command and control panel.

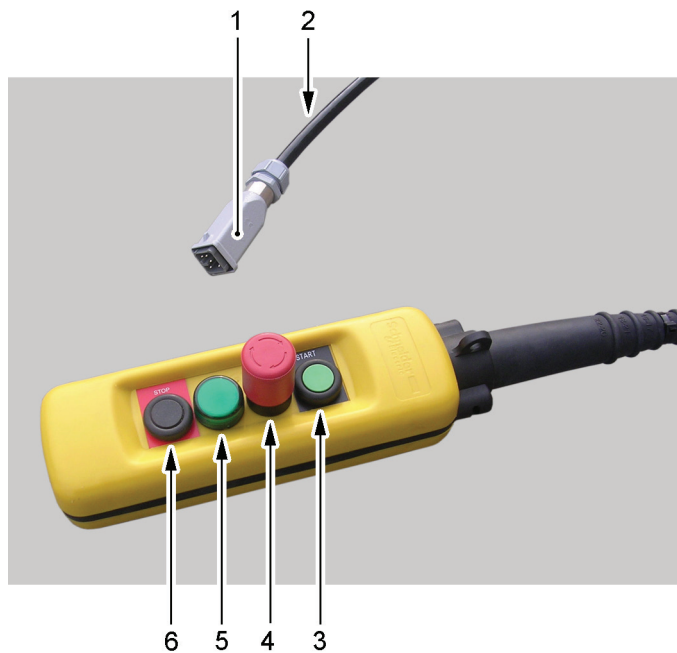
**LEGEND**

- 1 - Connector
- 2 - Connecting cable
- 3 - Heating cycle start pushbutton (START)
- 4 - Mushroom-head emergency stop pushbutton
- 5 - Heating in progress warning light
- 6 - Heating cycle stop pushbutton (STOP)

Figure 2.14 - Remote control

2.2.4 POWER CABLES

The power cables (see Figure 2.15/1), as already previously mentioned, allow to connect the generator to the coil. Every cable is equipped, at the relevant ends, with power connectors (2) of the same colour, either red or black, in such a way to make the connections between the parts easier.

The delivery consists of two pairs of power cables.



LEGEND

- 1 - Power cables
- 2 - Power connector

Figure 2.15 - Power cables

2.2.5 COMPRESSED AIR SYSTEM (OPTIONAL)

On the Induction Heating Generator IHG 120CU a system for generating compressed air may be installed as optional (see Figure 2.16).

Said system essentially consists of:

- an air compressor (2), directly installed on the engine (1), with a flow rate of 17 CFM at 2400 rpm engine speed (28.9 m³/hour at 2400 rpm engine speed);
- an air tank (6), with a capacity of 10 Gallons (37.9 ltrs);
- a pressure gauge (5);
- an air filter (3);
- a desiccator air filter (4);
- two air couplings for compressed air (7).



NOTE

The flow rate of 17 CFM for the compressor can be achieved only and exclusively with the engine (1) in “CRUISE” speed (see Figure 2.17/3).

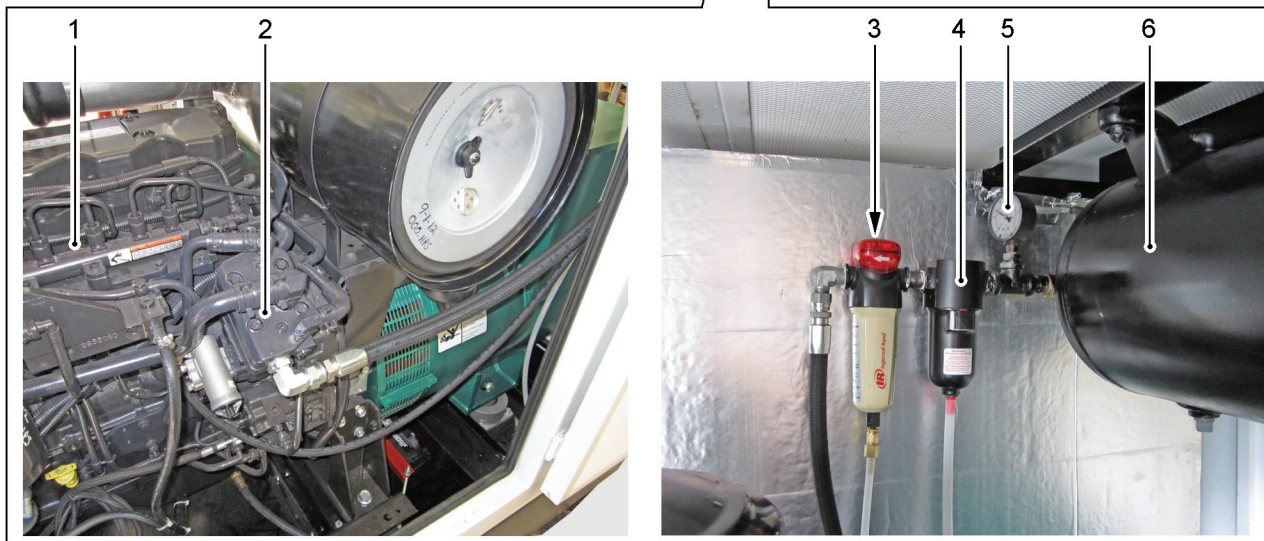

a. Internal arrangement of the components

LEGEND

- 1 - Engine
- 2 - Air compressor
- 3 - Air filter
- 4 - Desiccator air filter
- 5 - Pressure gauge
- 6 - Air tank

Figure 2.16 - Compressed air system (Optional)
(Sheet 1 of 2)



LEGEND

7 - Compressed air couplings

b. External arrangement of the components

Figure 2.16 - Compressed air system (Optional)
(Sheet 2 of 2)

2.2.6 120 VAC AUXILIARY GENERATOR (OPTIONAL)

On the Induction Heating Generator IHG 120CU a 120 Vac electric power generator may be installed as optional (see Figure 2.17).

That system essentially consists of:

- a 120 Vac auxiliary alternator, 60 Hz, 9 kW (2);
- an engine speed selector "IDLE/CRUISE" (3);
- two 120 Vac electric sockets (5).

The engine speed selector IDLE/CRUISE (3), when positioned on "CRUISE", permits that the engine (1) reaches its maximum speed.

When the engine operates at its maximum speed (CRUISE speed), it is possible to connect some service accessories to the two 120 Vac electric sockets (5), located inside the relevant covers (4).



WARNING

Use the 120 Vac electric sockets (5) exclusively when the engine (1) is operating at its maximum speed (CRUISE speed).

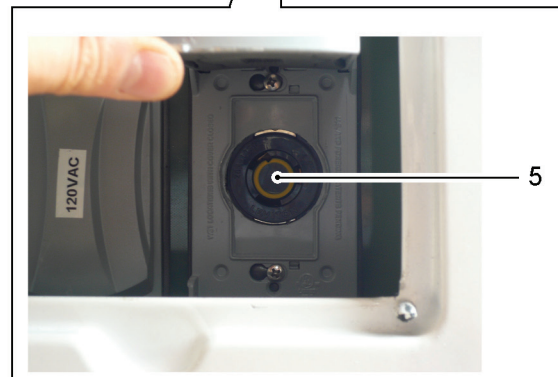
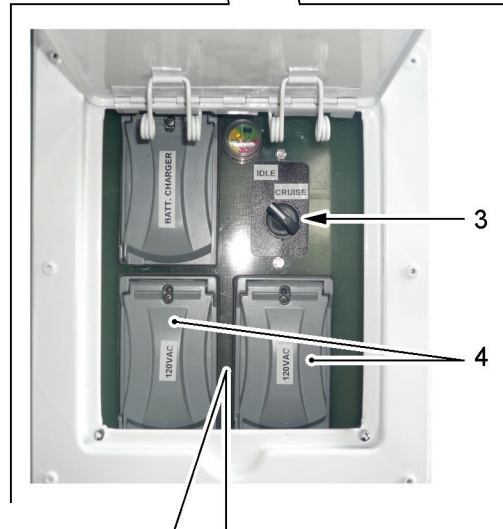
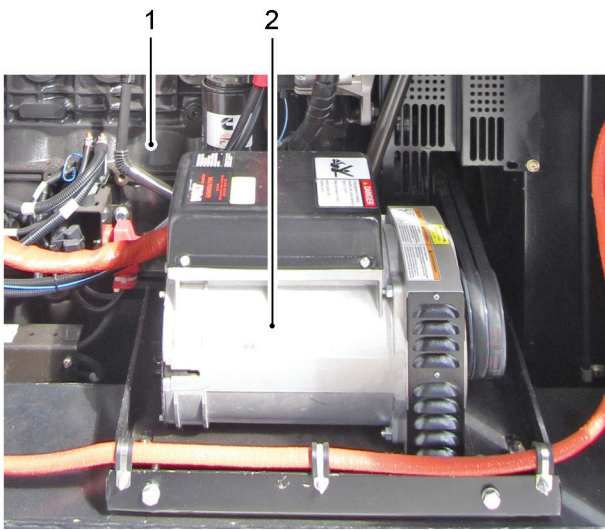

LEGEND

- 1 - Engine
- 2 - 120 Vac auxiliary alternator
- 3 - Engine speed selector "IDLE/CRUISE"
- 4 - Cover
- 5 - 120 Vac electric sockets

Figure 2.17 - 120 Vac auxiliary generator (Optional)

2.2.7 BATTERY CHARGER (OPTIONAL)

On the Induction Heating Generator IHG 120CU a battery charger (see Figure 2.18) may be installed as optional. The activation of the battery charger can be effected by simply connecting a 120 Vac socket to the electric plug (1) located inside the cover (2).

On the battery charger is also present an indicator (3) of the batteries charge state.

	<p>WARNING Do not power the command and control panel of the generator when the battery charger (see Figure 2.18) is operating.</p>
---	--

LEGEND

- 1 - Electric plug
- 2 - Cover
- 3 - Batteries charge state indicator

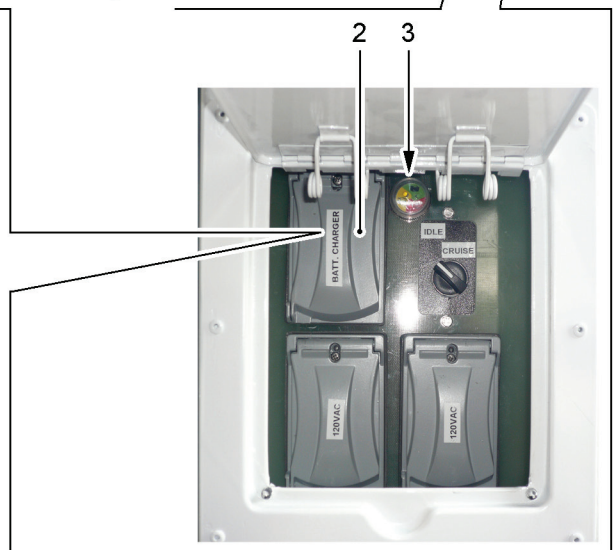
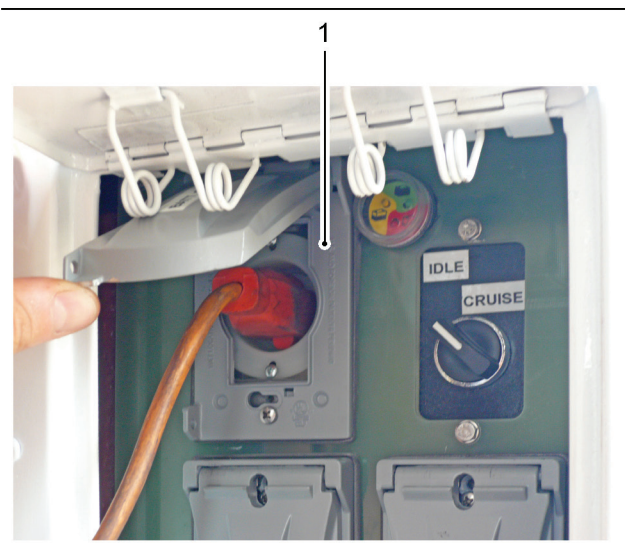

Figure 2.18 - Battery charger (Optional)

2.3 INDUCTION HEATING GENERATOR IHG 120CU TECHNICAL DATA

2.3.1 GENERATOR DIMENSIONS AND WEIGHT

- Length	2440 mm
- Width	1310 mm
- Height	2110 mm
- Weight	2400 kg



NOTE
Dimensions are expressed in mm.

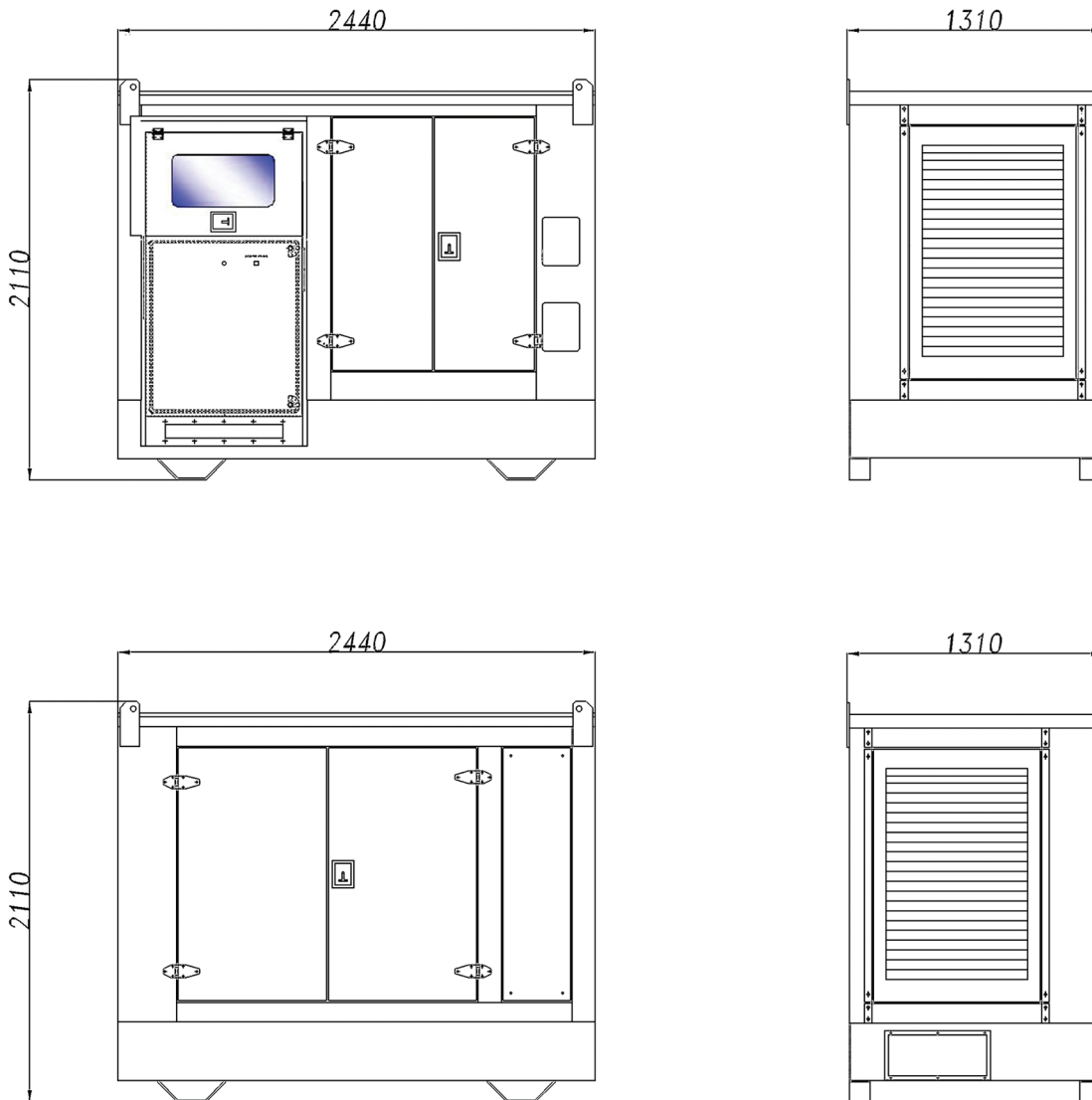

Figure 2.19 - Generator overall dimensions

2.3.2 MECHANICAL CHARACTERISTICS

2.3.2.1 Engine

- Manufacturer **CUMMINS**
- Model..... **QSB6.7**
- Type of Cycle..... **Diesel - Common rail, water-cooled with turbo intercooler**
- Cylinders' No. and arrangement..... **6 in-line**
- Maximum power (at 2400 rpm) **142 kW**

2.3.2.2 Compressed air system (Optional)

- Air compressor type **1 cylinder, water cooled**
- Air compressor flow (at 2400 rpm engine speed)..... **17 CFM (28.9 m³/hour)**
- Max pressure..... **110 PSI (758 kPa = 7.58 bar)**

2.3.3 ELECTRIC CHARACTERISTICS

- Generator
 - Maximum output voltage **165 V single-phase**
 - Frequency **480 Hz**
 - Power **120 kVA continuous, cosφ = 0.9, ambient temperature = 20 °C**
150 kVA at peak, duty cycle 50%, max ON 20', cosφ = 0.9, ambient temperature = 20 °C
- Batteries
 - Type..... **12 V - 100Ah - 830 A**
 - No..... **2**
 - Connection **in series**
- 120 Vac Auxiliary generator (Optional)
 - Output voltage (at 2400 rpm engine speed)..... **120 V, 60 Hz**
 - Max output power (at 2400 rpm engine speed)..... **9 kVA**

2.3.4 COILS' DIMENSIONS AND WEIGHT

	<p>NOTE The dimensions and weights relevant to the coils depend on the type of coil used. Consequently, reference shall be made to the identification plate applied on the same ones.</p>
---	--

2.3.5 POWER CABLES DIMENSIONS AND WEIGHT

- Standard length **15 m**
- Weight (standard length) **~ 100 kg**

2.3.6 PACKINGS' DIMENSIONS AND WEIGHT

2.3.6.1 Wooden base

- Length **~ 2700 mm**
- Width **~ 1450 mm**
- Weight **~ 100 kg**

2.3.6.2 Wooden crate

- Length~ 2700 mm
- Width~ 1450 mm
- Height~ 2700 mm
- Weight~ 500 kg

2.3.6.3 Pallet

- Length x width euro size
- Weight~ 15 kg

Chapter

3

SAFETY RULES

Any working machine can represent a possible danger.

3.1 SAFETY GENERAL PRINCIPLES

As far as it was possible, **TeSi s.r.l.** lavished the utmost efforts in designing the **Induction Heating Generator IHG 120CU** by making it intrinsically safe.

Besides, they equipped it with all the protection and safety devices held to be necessary, and, finally, they accompanied it with the sufficient information for allowing its safe and correct utilization.

If the Induction Heating Generator IHG 120CU is employed by observing the use instructions and is regularly subjected to the required maintenance, the user can be sure to operate on safe conditions; on the contrary, the inobservance of the use and maintenance rules, makes the Induction Heating Generator IHG 120CU dangerous both for the operator and for the other people.

**WARNING**

Before using the Induction Heating Generator IHG 120CU, carefully read the instructions supplied in this manual and follow the here reported indications.

It is besides absolutely necessary that the operator observes the safety indications relevant to the yard in which he is working.

If a warning message can't be fully understood, ask TeSi s.r.l. for the relevant explanations.

For safety purposes, it is anyway not sufficient to carefully observe the safety warnings; for the whole utilization time of the Induction Heating Generator IHG 120CU, it is necessary to foresee all the possible dangers and to make every effort in order to prevent them.

Never begin any work without having before ascertained that both his own and other people' safety are safeguarded.

Never undervalue his own doubts, and, if any uncertainty exists about the Induction Heating Generator IHG 120CU or about the work to be performed, get addressed to somebody competent.

Should any leaks or anomalous situations be noticed, it is obligatory to immediately stop the Induction Heating Generator IHG 120CU and to urgently inform either the yard foreman or the competent mechanisms about the event.

Always act with:

PRUDENCE - ATTENTION - PRECAUTION**CAUTION**

As far as all the possibly required explanations are concerned, please contact TeSi s.r.l..

3.2 SAFETY INFORMATION

The following recommendations are here supplied in order to reduce the risks of danger for people and things either when the Induction Heating Generator IHG 120CU is either operating or out of service.

	<p>WARNING Presence of high magnetic fields near the generator, the coil and the power cables realizing the connection between coil and generator.</p>
	<p>The most intensive presence of high magnetic fields can be found near the coil.</p>
	<p>People with pacemaker must pay attention and keep themselves at a proper distance. It is possible to have electromedical devices' failures.</p>

	<p>PROHIBITION Never use the Induction Heating Generator IHG 120CU beyond the limits defined in its planning phase; to exceed those limits can be dangerous and can cause damages to the Induction Heating Generator IHG 120CU itself. Don't try to improve the Induction Heating Generator IHG 120CU performances by applying any unapproved modifications.</p>
--	---

- The operator shall have all the required qualifications for using the Induction Heating Generator IHG 120CU.
- It is here reminded to the operators to adopt, during the Induction Heating Generator IHG 120CU utilization, an attentive and careful behaviour, in order to improve his own safety level, as well as that of other people and of the Induction Heating Generator IHG 120CU itself.
- The Induction Heating Generator IHG 120CU can't be used for any applications different from those stated by **TeSi s.r.l.**
- Neither connect the coil to the power connectors situated on the generator, nor start the same one if any signs of damages are noticed.
- Make sure that the environmental conditions fully correspond to the indicated ones.
- Execute several idle manoeuvres, being assisted by skilled personnel, in order to acquire the required sensibility for operating in fully safe conditions.
- DON'T tamper in any case the command and control panel.
- DON'T leave the protective hatch of the command and control panel open during the normal use of the Induction Heating Generator IHG 120CU, as that would sensibly and dangerously reduce the protection degree against external agents.
- Periodically check for the efficiency of the commands and controls present on the command and control panel as well as on the remote control.
- In case of an EMERGENCY, press the red mushroom-head pushbutton situated on the command and control panel or on the remote control; absolutely avoid resetting the red mushroom-head pushbutton before the engine has completely stopped.
- In case of a fire, extinguish it by using a powder extinguisher, **NEVER** by using water.
- Stretch the power cables, realizing the connection between generator and coil, far away from any mechanical moving mechanisms or from any sharpened objects.
- Exclusively entrust the connecting operations of the power cables, realizing the connection between generator and coil, to qualified personnel.
- Exclusively entrust the connecting operations of the grounding cable between the generator and the pipe on which it is necessary to operate to qualified personnel.
- Before starting the engine of the Induction Heating Generator IHG 120CU, make sure that the front and rear doors are closed; if not so, don't start the engine.
- Cut off the power supply to the generator before operating on the inner components, by acting on the red

- mush-room-head pushbutton, removing the ignition key and switching OFF the batteries switch.
- Don't use the Induction Heating Generator IHG 120CU when you are under the effect of some drugs or alcoholic drinks which could either alter or reduce your reactive quickness.
 - Always keep the Induction Heating Generator IHG 120CU clean, in particular as far as the command and control instruments are concerned.
 - Always when working on the Induction Heating Generator IHG 120CU, act with the utmost prudence and attention. Make every effort in trying to prevent any possible danger.
 - In order to contribute to a fully safe utilization of the Induction Heating Generator IHG 120CU, the operator can suitably integrate the information supplied by **TeSi s.r.l.** with additional working instructions, which shall obviously be complying with the instructions supplied in this manual.
 - The inobservance of the safety instructions reported on the transfer printings can lead to accidents. Keep the transfer printings clean and replace the ones become illegible or the lacking ones, before starting the working cycle. Make sure that the spare parts are equipped with the possible safety transfer printings.
 - The operator's concentration shan't be in any way either disturbed or interrupted during the Induction Heating Generator IHG 120CU operating cycle.
 - **NEVER** leave the command and control place during the operating cycle; this, in order to be in a position to promptly intervene in case of any anomalies on the Induction Heating Generator IHG 120CU.
 - The operator shall make sure that the working place is well illuminated and that it doesn't show any possibly dangerous condition. Should the illumination be scarce, provide to install the suitable artificial light devices.
 - It is absolutely forbidden to smoke, to drink or to eat during the Induction Heating Generator IHG 120CU operating cycle.
 - The access to the Induction Heating Generator IHG 120CU area of action is absolutely forbidden to the unauthorized personnel, consequently it is recommended to signal both visually and, possibly, acoustically the observance of that rule. Always fully observe all the safety rules in force for the Induction Heating Generator IHG 120CU user, and/or those in force in the country where it is used.
 - The Induction Heating Generator IHG 120CU **ISN'T** equipped with an extinguisher. It shall be a Customer's care to provide to get installed a suitable extinguisher on the working place, as well as to take care that the same one will be regularly checked by qualified personnel.
 - A defective Induction Heating Generator IHG 120CU can cause accidents, hurting both the operator and other people possibly present. Never use the Induction Heating Generator IHG 120CU on trouble conditions or if some of its parts are lacking. Before starting the work, make sure that all the maintenance procedures foreseen in this manual were completed.
 - It is absolutely forbidden to get near the engine when it is operating. For this reason, it is obligatory to keep the access doors to the engine compartment closed.

PROHIBITION

It is forbidden to open the access doors to the engine compartment, while the engine is operating. For that purpose, on the access doors there is a padlock. Such padlocks must be locked, while the engine is running, and the relevant key must be preserved by the person appointed to that task.

Only the appointed person can consciously authorize the opening of the access doors to the engine compartment.

TeSi s.r.l. held themselves as being exonerated from any responsibility if any accidents due to inobservance of the here indicated rules should take place.

- Don't intervene on the engine while it is still hot. Let it cool down before opening the access doors and, anyway, always wear the proper protective gloves.
- As the engine emits some exhaust gases harmful for the health, it was equipped with an exhaust pipe suitable for expelling the gases upwards, without that they can concern the operator's working area. It is therefore absolutely forbidden to let the engine operate without the relevant exhaust pipe.
- Use the adequate personal safety means near the engine exhaust pipe, which can reach high temperatures, and don't lean either inflammable substances or materials to that part when it is hot.
- If the Induction Heating Generator IHG 120CU is used in an indoor ambient or by reduced ventilation condi-

tions, foresee a proper intake for the exhaust gases.

- The engine produces vibrations. In order to prevent them from being transmitted to the whole structure, the engine was elastically insulated from the frame.
- Refuelling shall be always carried out by absence of free flames, and during that operation it is absolutely forbidden to smoke.
- All fuels and the majority of the oils are inflammable. Consequently, avoid getting them spread on hot surfaces or on electric components.
- Make sure that the maximum current value of the coil which is going to be used corresponds to that specified on the identification plate of the same one.

	<p>PROHIBITION Never set a current higher than the 50% of that indicated on the relevant identification plate applied on the coil.</p>
---	---

- The power connectors for the connection of the coils can be under voltage, and, even if insulated, because of their characteristics they mustn't be used in any different way than the foreseen one. The connection must be exclusively realized by using the relevant power cables.

	<p>PROHIBITION Don't introduce either objects or your fingers into the power connector which is integral with the generator, and into the connectors of the power cables, when an end of the same ones results being connected to the generator.</p>
---	---

	<p>CAUTION If necessary, clean the power connectors by using compressed air, and, in their external part, by using a dry wiping cloth.</p>
--	---

- Periodically check that the hooking points foreseen for hoisting the coil and the relevant belts don't show any signs of deterioration.

	<p>PROHIBITION Never open or remove the coils when the Induction Heating Generator IHG 120CU is in the heating cycle phase. Danger of:</p> <ul style="list-style-type: none"> - electric shock; - damages to the generator.
---	--

	<p>PROHIBITION For no reason carry out the disconnection of the power cables during the heating cycle. Danger of:</p> <ul style="list-style-type: none"> - electric shock; - damages to the generator.
---	---

- Use the 120 Vac electric sockets exclusively when the engine is operating at its maximum speed (CRUISE speed).
- Do not power the command and control panel of the generator when the battery charger is operating.

3.3 EMERGENCY BEHAVIOURS

It is extremely important to very carefully read the following information. Make sure that the personnel charged with the plant maintenance perfectly knows the here supplied information.

Should any wrong behaviour cause an accident situation, immediately request the intervention of personnel qualified in supplying first aid. While waiting for the first aid personnel to arrive, the following general instructions are here supplied in order to lend the first assistance.

3.3.1 FIRE

**CAUTION**

It shall be a Customer's care to get installed a proper fire-fighting system in the yard or, in particular, near the Induction Heating Generator IHG 120CU.

Extinguish the fire by using either carbon dioxide, dry chemical substance or powder extinguishers. Never use water: by doing so, you could increase the fire or get fulminated, if the fire was originated by electricity. Immediately call the firemen.

3.3.2 LUBRICANTS

The lubricant is toxic. Handle the lubricant as little as possible, and protect the skin by using purposed creams and gloves.

Every time it is necessary to move some lubricant, it will be required to observe the best care and hygiene rules both referred to the person and to the factory.

Never stock lubricants in open containers or in containers not countermarked by the proper label.

The lubricants' elimination must be performed in full compliance with the relevant rules in force.

Don't keep oil-drenched clothes in your pockets.

Wash the dirty garments before using them again.

Throw away the lubricant-drenched shoes.

3.3.2.1 Lubricants' first aid

Eyes: in case of contact with the eyes, abundantly rinse the eyes with water for 15 minutes: if the inflammation persists, have recourse to the medical aids.

Swallowing: don't provoke the vomit and have recourse to the medical aids.

Skin: carefully wash by using water and soap, or use a special detergent.

Using a nails' brush can help.

Never use gasoline, diesel fuel or paraffin for performing the washing.

3.3.3 SCALDS

1) Extinguish the flames on the scalded person garments by using:

- a water flood;
- a powder extinguisher, by avoiding to address the jet on the victim face;
- some blankets to be thrown on the victim or by rolling the victim itself on the ground.

2) Don't detach any fabrics' tatters adhering at the skin.

3) In case of scalds caused by liquids, remove quickly but cautiously the wet garments.

4) Cover the scald with a purposed anti-scald packet or by using a sterile bandage.

3.3.4 CARBON MONOXIDE INTOXICATIONS

The carbon monoxide contained inside the engine exhaust gases is odourless and dangerous, both because it causes intoxication and because it creates, by getting into contact with the air, an explosive mixture.

In an indoor ambient, the carbon monoxide is very dangerous, because it can reach the critical concentration within a quite short time.

In case of first aid to the victim of a carbon monoxide intoxication in an indoor ambient, immediately proceed to ventilate the room, in order to reduce the gas concentration.

When acceding to the room, the helper shall hold his breath, don't light flames, switch on lights or actuate electric bells or phones, in order to prevent any explosion.

Carry the victim of the carbon monoxide intoxication into a ventilated place in the open air, laying him on his side, if he is unconscious.

3.3.5 CORROSIONS

The corrosion to the eyes is provoked both by the lubricating oil and by the water and cement powder mixture.

Rinse the eye with water for at least 20 minutes, by keeping the eyelids open, in order to allow the water to flow along the eye contour and by moving the eye in every direction, having then immediately recourse to the medical aids.

3.3.6 FULGURATIONS

The fulguration can be provoked by:

- external electric wirings;
- electric equipments.

In both cases, the voltage value causes the passage of high currents through the human body.

In case of a short circuit provoked, for example, by a metal tool, some flooding could arise, causing scalds.

In those cases, try by every mean to cut out the current before touching the victim.

Shouldn't this be possible, remember that any other attempt is highly dangerous also for the succourer; consequently, the rescue attempt must be performed by using fully insulating means.

3.3.7 WOUNDS AND FRACTURES

The vastness of the possible cases and the specificity of the interventions necessarily requires the intervention of the medical structures.

In case of bleeding, press the wound from the outside, up to the succourers' arrival.

In case of a fracture, don't move the part of the body concerned by the fracture itself, and, only if absolutely necessary, displace the victim with the utmost care.

3.3.8 ELASTOMERIC MATERIALS

The elastomeric materials which were subjected to temperatures higher than 300° C must be handled by observing the following procedure. Wear heavy rubber gloves and special protective glasses.

- 1) Remove the material and put it into plastic bags.
- 2) Wash the polluted area by using an alkaline solution.
- 3) Then wash by using water and some cleansing agent.
- 4) Put all the polluted material used in this operation into plastic bags and eliminate them according with the relevant laws in force.

**PROHIBITION**

Don't burn any fluoroelastomeric materials.

3.3.8.1 First aid

In case of contamination of skin or eyes, immediately and abundantly rinse either in clean water for at least 15 minutes, having then immediately recourse to the cares of a doctor.

3.4 SAFETY IN MAINTENANCE**WARNING**

Before intervening on any component, either mechanical or electrical, the maintenance liable technician must remove the ignition key, switch OFF the batteries switch for a better safety and preserve on himself the key until the maintenance intervention is over, and only after that he can restore the operation normal conditions, for carrying out the check on the Induction Heating Generator IHG 120CU.

That, in order to prevent anybody from restarting the Induction Heating Generator IHG 120CU without informing the personnel carrying out the maintenance intervention.

Besides, a warning notice shall be applied on the Induction Heating Generator IHG 120CU, informing that the same one is presently subjected to a maintenance intervention.

The maintenance liable technician is the main liable person for any possible accident which could occur during these operations; it is therefore recommended to execute the above described procedure, in order to prevent every possible serious and unpleasant inconveniences.

- The maintenance technician shall have carefully read this manual before carrying out any operation on the Induction Heating Generator IHG 120CU.
- The maintenance must be performed by qualified personnel. Before starting to perform the maintenance operations, make sure that the Induction Heating Generator IHG 120CU is on safety conditions.
- When it is necessary to intervene on the Induction Heating Generator IHG 120CU in order to execute any maintenance operation, the maintenance technician shall ascertain to operate by a good visibility (by possibly using external illuminating equipments), in order to prevent any possible risk of getting hurt because of the scarce visibility.
- The maintenance technician shall be sure that no possible dangerous conditions are present.
- Cleaning the metal parts by using inadequate solvents can cause corrosion. Exclusively use detergents and solvents of adequate type.
- Don't clean the components of the command and control panel by using any corrosive agents, but only by using a dry wiping cloth.
- Don't try to carry out either repairs or any other maintenance operation without having previously asked the TeSi s.r.l. personnel for advice.
- Unauthorized modifications can lead to hurts or damages; before carrying out any modification on the Induction Heating Generator IHG 120CU, contact the TeSi s.r.l. personnel.
- When some metal pins are either driven or extracted, it is possible to be hurt by metal splinters: always wear protective glasses and use a soft mallet or drift.
- Before either connecting or disconnecting an electric component, attentively analyse the electric circuit: a wrong connection can lead to hurts and/or damages.

- When the batteries are handled, it is necessary to prevent the electrolyte from coming into contact with the hands. Therefore, use the suitable protective gloves. All possible sparks or flames near the batteries must be absolutely avoided, therefore also smoking is forbidden.
- Don't use any flammable fluids during the cleaning operations.
- The maintenance must be carried out by Induction Heating Generator IHG 120CU turned off, after having removed the ignition key from the command and control panel and switched OFF the batteries switch.
- A scarce communication level can lead to accidents. If one or more persons are working on the Induction Heating Generator IHG 120CU, make sure that each of them is informed about the work the other ones are performing. By not adopting the above mentioned precautions, the possibility is left open to very serious accidents and even to death.
- By not constantly wearing the adequate garments, there is still the possibility of serious accidents: fluttering garments can get caught into the machine parts. Always wear the adequate protective garments, complying with the kind of work you are performing, as, for example: helmet, safety shoes, protective glasses, properly-sized overalls, ears-protections and gloves for industrial use; button the cuffs, don't wear ties or scarves and keep long hair dressed in a pony-tail.
- Gaskets and O-Rings incorrectly mounted, damaged or worn out can provoke leaks and accidents: if not otherwise established, immediately replace the damaged components. Don't use either trichloroethylene or thinners for paints near the O-Rings and the gaskets.
- Some gaskets or oil seals may contain elastomeric material like Viton, Fluorel and Technoflon. The elastomeric materials exposed to high temperature can produce highly corrosive acids.

**WARNING**

The acids produced by elastomeric materials subjected to high temperatures can cause serious scalds.

- The new components kept at ambient temperature can be handled without any particular precaution.
- The elastomeric components which were exposed to 300°C temperatures don't need to be handled with any special precautions. If there are some marks of decomposition (for example, burnings), get referred to Paragraph 3.3 "Emergency behaviours".

**PROHIBITION**

Don't touch either the component or the surrounding area.

**CAUTION**

It is here pointed out that, inside the Induction Heating Generator IHG 120CU there are some materials which, if dispersed in the environment, can create serious ecological damages (for example, lubrication grease, fuel, auxiliary cleaning material, greasy wiping clothes or fuel drenched ones, etc.).

It is reminded that the collection and the elimination of the exhausted oils and of the over enlisted components are regulated by relevant laws.

Deliver all the over mentioned residuals to the authorized collecting centres.

It is severely forbidden to get rid of the residuals by depositing them in abusive dumps or, even worse, by discharging them into the rivers or into the sewerage.

The relevant laws in force, exactly defined for every country, foresee heavy penalties for the transgressors.

TeSi s.r.l. decline every responsibility in case the here enlisted safety and use instructions shouldn't be strictly observed.

3.5 SAFETY DEVICES

The Induction Heating Generator IHG 120CU is equipped with safety systems purposed either to safeguard the operator's safety or to prevent damages to the components of the generator itself.

3.5.1 EMERGENCY PUSHBUTTON

This red mushroom-head pushbutton (see Figure 3.1), which is situated both on the command and control panel and on the remote control, must be pressed every time the operator identifies a dangerous situation; by pressing it, the Induction Heating Generator IHG 120CU instantaneously determines the following conditions:

- immediate stop of the engine;
- immediate shut off of the power supply to the coils.



a. Command and control panel

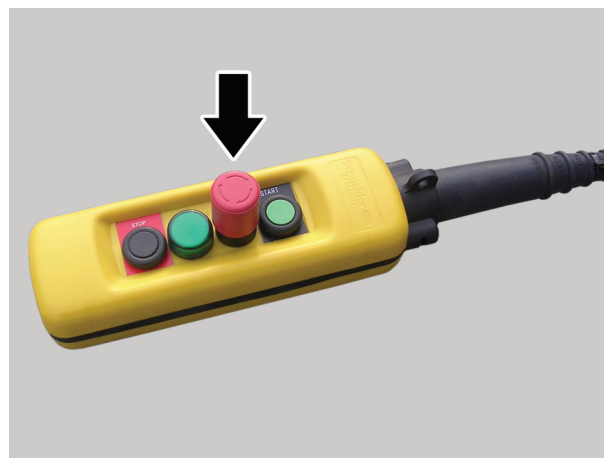

b. Remote control

Figure 3.1 - Emergency pushbutton

3.5.2 HOISTING ACCESSORIES

In order to allow its handling and a correct use during the whole working cycle, the coil was equipped with some accessories (belts), allowing to get hold of it by using a usual crane (see Paragraph 4.4.1).

During the properly said transport phases, the hoisting belts present on the coil must be fastened on the same one in such a way not to hinder the operations, and besides, both the generator and the coil must be fastened to the vehicle platform by means of suitable slings, ropes, tie rods etc., in order to prevent any sudden and unexpected load side skids.

As far as the Induction Heating Generator IHG 120CU installation is concerned, carefully observe the indications reported in Chapter 5 "Installation".

3.5.3 ELECTRIC PLANT

The electric plant was realized in such a way to prevent, if used within a range of temperatures comprehended between -15 °C and +45 °C, any risk due to the electric power, as defined by the Machinery Directive (98/37/CE).

**NOTE**

If requested by the Customer, TeSi s.r.l. can supply versions with a temperatures' range comprehended between -40 °C and +50 °C.

All the used components are self-extinguishing.

Warning lights, situated on the command and control panel, signal any possible anomaly or emergency situation; as soon as a signaling lights up, immediately check for the problem gravity, and, if the situation requires it, stop the Induction Heating Generator IHG 120CU and don't start it up again until the problem hasn't been solved.

3.5.4 ELECTRIC SAFETY DEVICES

The Induction Heating Generator IHG 120CU is equipped with an electronic system, which constantly performs the following checks:

- generator maximum output voltage;
- alternator maximum output current;
- alternator maximum temperature;
- (clamp) open coil;
- leakage to ground;
- engine oil low pressure;
- battery charge level;
- engine high temperature.

As the above mentioned anomalies can prove harmful for the operator during use of the Induction Heating Generator IHG 120CU, they are automatically signalled through the warning lights present on the command and control panel, and, in case of particularly serious anomalies, the safety devices get actuated, which impede the occurrence of conditions which would be dangerous even for the efficiency of the Induction Heating Generator IHG 120CU.

3.5.5 COMMAND AND CONTROL PANEL PROTECTIVE TRANSPARENT HATCH

The transparent hatch (see Figure 3.2), provided for protecting the command and control panel, must always be closed during the generator normal operating phases, in such a way to prevent, in first place, any foreign

personnel from accidentally interact on the panel itself, and, in second place, for preventing dust or humidity from damaging both the panel and the relevant components.

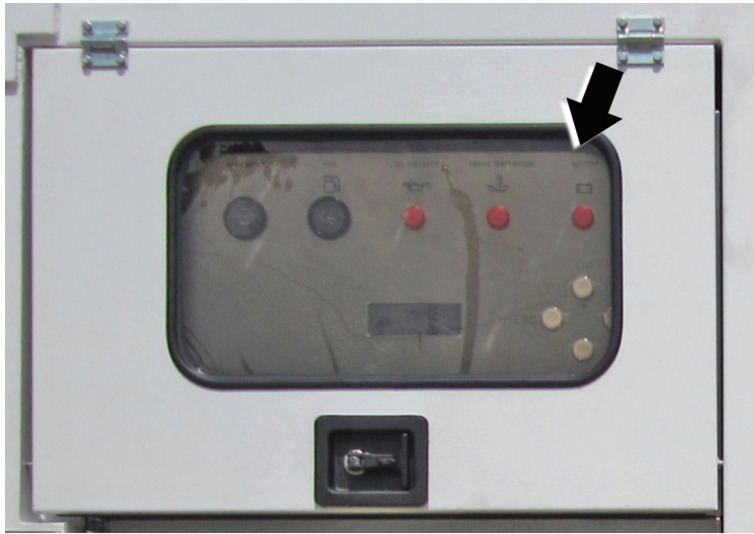

Figure 3.2 - Command and control panel protective transparent hatch

3.5.6 GROUNDING

On the rail, a point is foreseen for the grounding of the generator whole metal mass (see Paragraph 5.4.6). Such point is countermarked by a plate showing the specific grounding symbol (see Figure 3.3).



WARNING

It is obligatory to perform the grounding of the generator, together with the relevant pipe to be treated.



Figure 3.3 - Grounding point

Chapter

4

PACKING, HANDLING, TRANSPORT, RECEPTION, STORAGE AND DISMANTLING

4.1 GENERAL WARNINGS



WARNING

The majority of the accidents on the work place are due to inobservance of the most elementary safety rules. It is absolutely necessary that anybody operating on the Induction Heating Generator IHG 120CU perfectly knows and strictly observes the rules reported both in this publication (see Chapter 3 "Safety Rules") and on the warning plates.

4.2 PRELIMINARY OPERATIONS

Before proceeding to a possible packing, and anyway before transporting the generator, carry out the following preliminary operations:

- 1) Open the access door to the engine (see Figure 4.1/3), situated on the front part, by acting on the relevant handle (1), after having removed the locking padlock and switch OFF the battery switch (2).

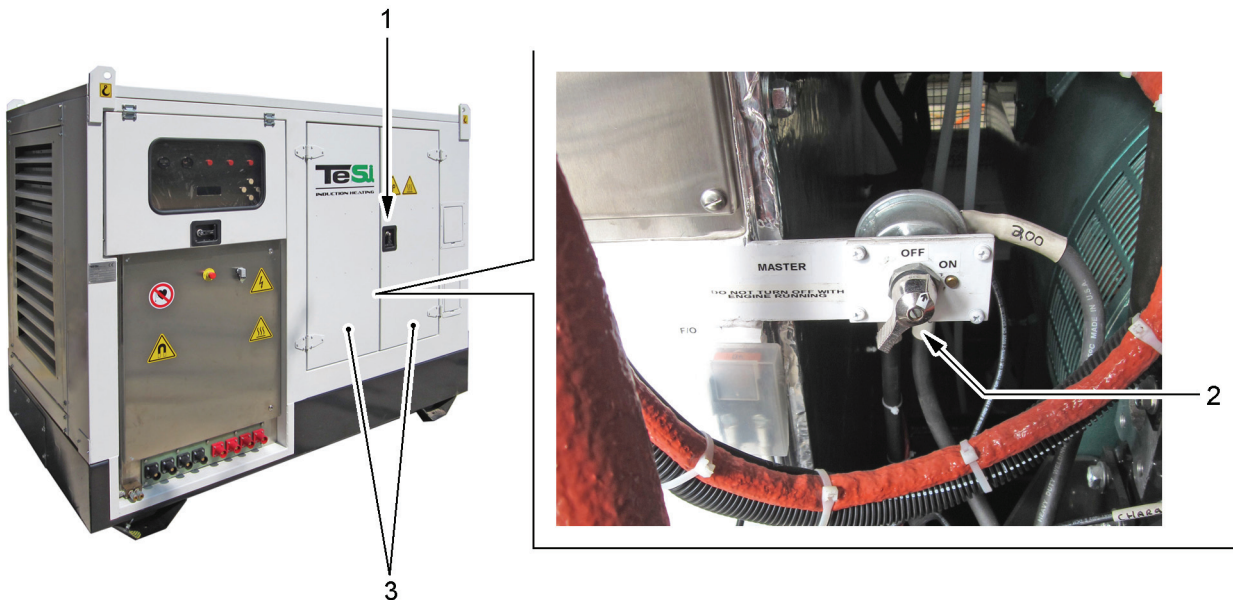

Figure 4.1 - Switch OFF the battery switch

- 2) Unscrew the screws (see Figure 4.2/1) fastening the access cover (3) to the fuel drain cock (5), situated in the generator right side; then remove the screws (1), the washers (2) and the cover (3).
- 3) Position under the drain cock (5) a suitable receptacle, and, by acting on lever (4), slowly drain all the fuel contained inside the tank; then, by acting on lever (4), close the drain cock (5).



WARNING

The operation of draining the fuel from the tank must always be carried out by absence of free flames and by observing the prohibition to smoke.

- 4) Install cover (3) in its seat and lock it there by means of the screws (1) and relevant washers (2).
- 5) Close the access door (see Figure 4.1/3), by acting on the handle (1), and lock it by means of the locking padlock.

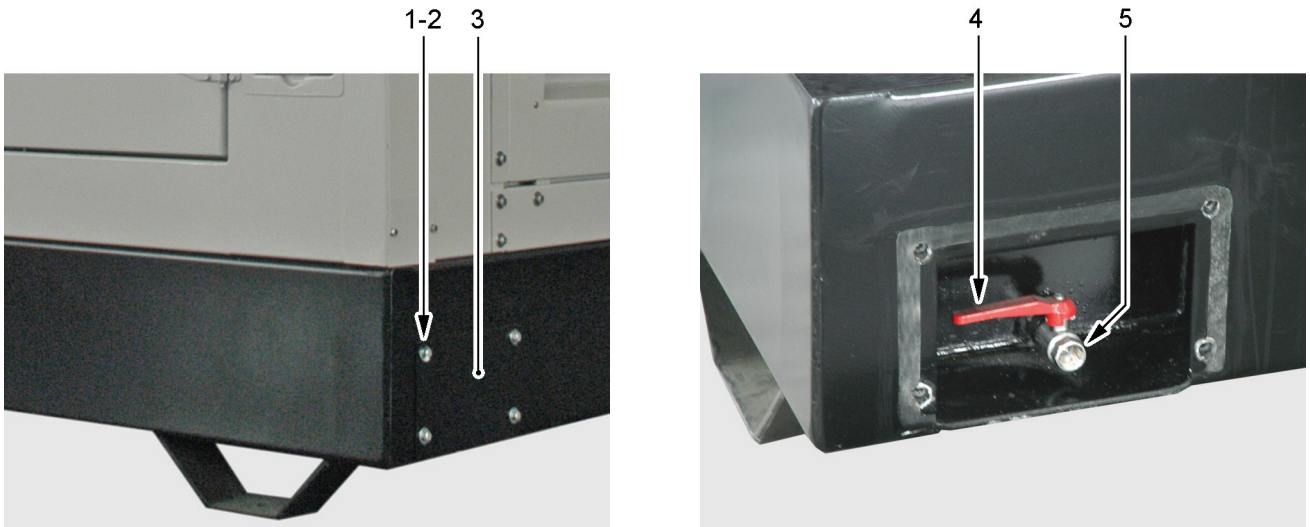

Figure 4.2 - Draining fuel from tank

4.3 PACKING

Insert into a cardboard box the “accessories”, consisting of the remote control and the Engine Owners Manual QSB4.5 and 6.7; seal the box and place it into the engine compartment, as illustrated in Figure 4.3.

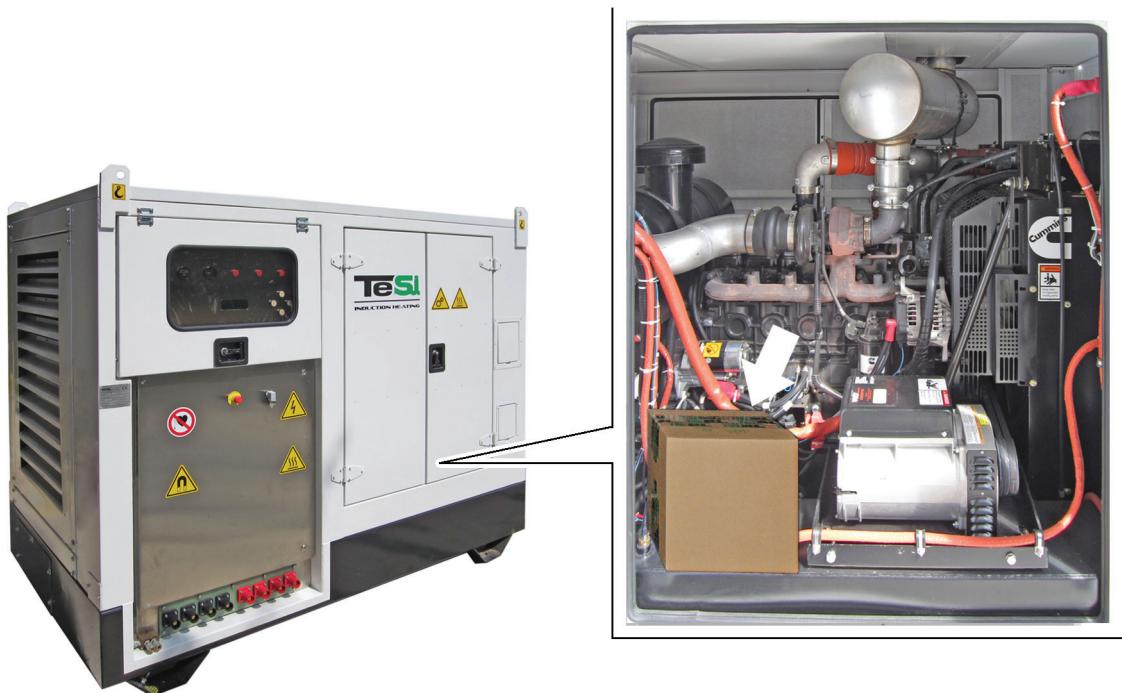

Figure 4.3 - Packing and displacement of the cardboard box containing the “accessories”

The Induction Heating Generator IHG 120CU must be considered as being the assembly formed by two fully distinct parts, the generator and the coil. When it is necessary to transport them, they don't require any particular packing, because they were designed in order to withstand the conditions present in outdoor environments.

Anyway, if requested by the Customer or agreed with Him, they can be packed by using the here following reported modalities:

- polyethylene bubble-pack sheeting for covering the generator and the possibly included coils;
- fastening on a wooden base with optional protective wooden crate (see Figure 4.4a). In this case, the generator shall be fastened to the base through the four rails (or support stands), situated in the structure lower part, while the coils possibly present shall be fixed by purposed tie rods and by using the relevant lifting rings.

The transport and packing of the power cables (see Figure 4.4b) shall be, on the contrary, realized through a (euro sized) pallet, on which the cables themselves shall be arranged and then protected by applying some polyethylene sheets over them.



a. Induction Heating Generator IHG 120CU packing





b. Power cables packing

Figure 4.4 - Packing

4.4 INDUCTION HEATING GENERATOR IHG 120CU HANDLING

Handling the Induction Heating Generator IHG 120CU is a complex operation, and therefore requires the simultaneous intervention of several skilled operators.

	<p>WARNING All the operations relevant to the Induction Heating Generator IHG 120CU must be exclusively performed by skilled personnel and by strictly observing the relevant rules in force both for the user and in the country where the machine will be used.</p>
---	--

	<p>WARNING The handling of the Induction Heating Generator IHG 120CU must take place by full safety conditions: generator turned off, fuel tank empty and coils disconnected. Always consider the generator and the coils as being independent units.</p>
---	--

	<p>WARNING Make always sure about the capacity of the system used for handling the generator, by consulting Table 4.1 which is referred to the weights.</p>
---	--

In Table 4.1, the list of the weights concerning the generator, the coils, the power cables and the possible packing systems is reported, in order to correctly define the most suitable hoisting means to be used, for correctly handling the parts.

Generator and coils may be combined in a single group, when packed in a wooden crate, and therefore the weight to be hoisted will correspond to the sum of the weights relevant to the single components given in the table.

	<p>NOTE In order to know the weight of the different coils according with their diameter, consult the identification plate applied on every coil.</p>
---	--

Table 4.1 - Weights

COMPONENT	WEIGHT (kg)
Generator	2400 kg
Coil	According with the relevant diameter
Packing consisting of a wooden base	~ 100 kg
Packing consisting of a wooden crate	~ 500 kg
Power cables	~ 100 kg
Pallet for power cables	~ 15 kg

The Induction Heating Generator IHG 120CU can be handled by using suitable mechanical means, as here following specified:

- a) using a crane, by acting from above;
- b) using a forklift, by acting from below.



NOTE

For handling the generator and the coils, the use of a crane is recommended, even if, later on, the indications concerning the generator handling by using a forklift truck will be supplied.



NOTE

For handling the power cables, the use of a forklift truck is recommended.

In the following paragraphs, the handling of the generator, of the possibly present coils and of the power cables is taken into consideration without the relevant packings; should, on the contrary, the packings be present, the over mentioned parts shall be handled by using a suitable hoisting means, according with the type of packing adopted.

4.4.1 HANDLING BY USING A CRANE



CAUTION

The handling performed by using a crane must be exclusively carried out by trained personnel, qualified for operating with such means.

4.4.1.1 Hooking procedure

a) Generator



WARNING

Before using the ropes for handling the generator, make sure that the ropes' characteristics fully meet the requirements demanded by the relevant directives in force.

- 1) Hook suitable ropes into the purposed holes (see Figure 4.5/2) machined on the four plates (1) situated on the generator (3) upper part.
- 2) Hook the ropes' other end to the crane block and carefully hoist, by making sure that the generator (3) get correctly lifted.

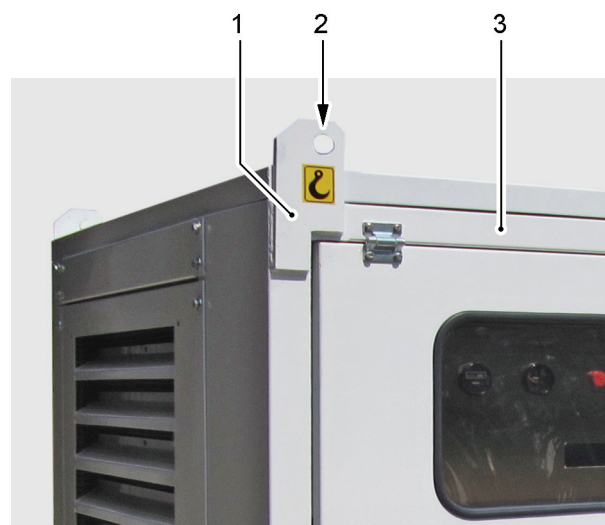

Figure 4.5 - Generator hooking

b) Coils

**NOTE**

The standard clamp coil handling can only and exclusively take place if the same one is closed. If not so, close it by acting on the relevant handle.

**NOTE**

The heavy duty clamp coil handling can only and exclusively take place if the same one is closed. If not so, close it by acting on the relevant closing control pedal.

- 1) Get the purposed belts (see Figure 4.6/3), delivered jointly with the coil (4), hooked to the omega clevis (1).
- 2) Get the omega clevis (1) hooked to the crane block (2), and carefully hoist, by making sure that the coil (4) gets correctly lifted.

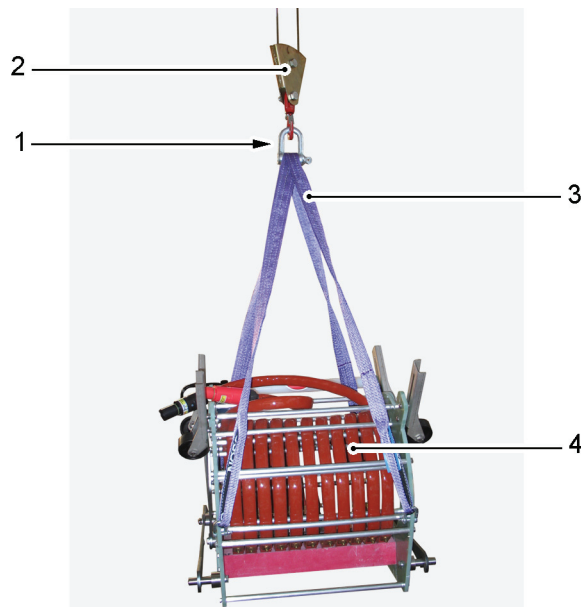

Figure 4.6 - Coil hooking

**PROHIBITION**

DON'T either transit or stay under the generator and/or under the coil during the hoisting and handling operations.

4.4.2 HANDLING BY USING A FORKLIFT TRUCK**NOTE**

By using a forklift truck, the handling is limited to the generator and to the power cables, if these last ones are positioned on a pallet, as the coil isn't equipped with rails for getting the forks inserted in, but only with purposed hoisting belts.

4.4.2.1 Procedure

a) Generator

- 1) Move the forklift truck near the rails (see Figure 4.7/2), situated in the generator (1) lower part, and adjust the distance between the forks in such a way that the same ones get aligned with respect to the rails (2).
- 2) Insert the forks into the four rails (2) (which are usually considered as being the generator stands), for the whole width of the generator (1) and carefully hoist, by making sure that the same one gets correctly lifted.



Figure 4.7 - Generator handling, by using a forklift truck

4.4.2.2 Procedure

a) Power cables

- 1) Get the forklift truck near the purposed seats machined on the pallet (see Figure 4.8) and adjust the distance between the forks, in such a way that the same ones result to be aligned with respect to the pallet seats.
- 2) Insert the forks into the pallet seats for the pallet whole width and carefully hoist, by making sure that the same one gets correctly lifted.



Figure 4.8 - Power cables handling

4.5 TRANSPORT

The motor vehicle to be used for transporting the Induction Heating Generator IHG 120CU must fully meet the capacity requirements, according with what reported in Table 4.1, and be equipped with an antislip loading flatbed with a high friction coefficient.

The generator, the coils and the pallet with the power cables must be anchored to the motor vehicle flatbed by means of slings, ropes, tie rods etc., in such a way not to create any deformations and to prevent any possible load turnover when the motor vehicle takes a curve or by sudden stops. Besides, the motor vehicle must be equipped with a covering sheet.

4.6 CHECK AT GOODS' RECEPTION

At goods' reception, immediately check for the packing integrity (if any packing is present). Should any external damages be noticed, open the packing and extract the generator and the coil, as indicated in Paragraph 5 "Installation", and check for their condition, by also verifying the full compliance with the identification plate data (see Paragraph 1.1), with those specified in the transport freight bill and in the order confirmation.

Should any damages to the components or any irregularities in the delivery be found out, immediately inform both TeSI s.r.l. and the carrier who delivered the goods.

4.7 STORAGE

4.7.1 GENERAL

Should a storage period be foreseen before the installation, with the original packing, observe the instructions reported in Paragraph 4.7.2.

Should the Induction Heating Generator IHG 120CU be stored after its use, for a more or less long period, observe what reported in the following Paragraphs 4.7.2 and 4.7.3.

4.7.2 ENVIRONMENTAL REQUIREMENTS

Storage must be performed in a dry, dust- and condensate-free ambient, with a temperature comprehended

between -40 °C and +50 °C, as inside the generator there are the electronic cards and the batteries for starting the engine.

4.7.3 OPERATIONS TO BE CARRIED OUT BEFORE STORING THE INDUCTION HEATING GENERATOR IHG 120CU

- 1) Switch OFF the battery switch (see Paragraph 4.2).
- 2) Drain all the fuel contained inside the tank (see Paragraph 4.2).



NOTE

If they aren't used for a long period, the batteries allowing to start the engine can possibly get discharged; the most frequent reason leading to a batteries' early discharge are small dispersions inside the electric circuit.

- 3) Carry out all the checks foreseen on the engine, according with the indications reported in the relevant "Owners Manual - QSB4.5 and 6.7", delivered by TeSi s.r.l. as a Joined Publication to this manual.
- 4) It is recommended NOT to leave the generator and the coils directly resting on the ground, but to interpose between them and the ground itself some wooden or similar material beams.

4.8 DISMANTLING

The **Induction Heating Generator IHG 120CU** hasn't any limits to its lifespan, exception made for those due to an excessive wear due to heavy use.

The machine dismantling doesn't create any particular problems. The Induction Heating Generator IHG 120CU can be disassembled and, after having separated the different materials composing it, eliminated. Pay a particular attention to those substances which must be considered as being polluting.

In Table 4.2, the list of the main materials composing the Induction Heating Generator IHG 120CU, is reported.

Table 4.2 - Materials composing the Induction Heating Generator IHG 120CU

MATERIAL	DISPLACEMENT
Acids and bases	Batteries for starting the engine
Inflammable products	Fuel inside the engine tank
Lubricating oil	Inside the engine
Coolant	Inside the engine
Iron	Structure and internal components
Aluminium	Command and control panel, internal components and coils' crosspieces
Steel	Engine components
Copper	Electric conductors and bars for connecting the capacitor battery inside the generator General wirings inside the electric board
Fiberglass	Coils' frame
Wood	Possible transport packing
Polycarbonate	Command and control panel protection

**WARNING**

A particular attention must be applied in eliminating the engine lubricants (such as oil, lubrication grease, etc.) and the electric components (such as battery, etc.), as well as the electronic ones.

Those products must be eliminated by strictly observing the relevant rules in force in the country, where the Induction Heating Generator IHG 120CU is used.

Inobservance of those directives can cause quite serious damages to people, animals and environment.

The operator is held for being liable for the possible faults and for the inobservance of the above mentioned rules.

PAGE LEFT
INTENTIONALLY BLANK

Chapter

5

INSTALLATION

5.1 GENERAL WARNINGS



WARNING

The majority of the accidents on the work place are due to inobservance of the most elementary safety rules. It is absolutely necessary that anybody operating on the Induction Heating Generator IHG 120CU perfectly knows and strictly observes the rules reported both in this publication (see Chapter 3 “Safety Rules”) and on the warning plates.

5.2 REMOVAL OF THE PROTECTIVE PACKINGS AND PRELIMINARY OPERATIONS

The procedure for removing the possible packings from the generator and from the coils is quite simple but very important, in order to prevent the possibility of annoying inconveniences. Therefore, according with the type of packing used, it is recommended to strictly observe the here following reported instructions:

- remove the bubble-packing polyethylene sheets both from the generator and from the coils jointly delivered;
- open the wooden crate and remove the clamps locking the four rails (or support stands), situated in the structure lower part, to the wooden base, while for the coils possibly present, it will be necessary to remove the purposed fastening tie rods from the relevant lifting rings.

As far as the removal of the power cables is concerned, it will be necessary to remove both the polyethylene sheets and the cables themselves from the pallet.



NOTE

If a packing is present, it will be necessary to preserve it during the whole lifespan of the Induction Heating Generator IHG 120CU, in order to have the possibility to use it again, in case of a new machine handling.

Remove from inside the engine compartment the cardboard box (see Figure 4.3), and, after having opened it, extract the remote control and the Engine Owners Manual - QSB4.5 and 6.7.

5.3 HANDLING

As far as the handling of the generator, of the possibly present coils and of the power cables is concerned, reference shall be made to Paragraph 4.4.

5.4 INSTALLATION OF THE INDUCTION HEATING GENERATOR IHG 120CU

5.4.1 MINIMUM DISTANCES TO BE OBSERVED DURING THE GENERATOR INSTALLATION

In Figure 5.1, the minimum distances are illustrated, which must be observed during the generator installation, in order to make it possible for the operator to carry out on the generator all the foreseen use operations and to easily intervene during the execution of some maintenance operations.

The minimum distance to be observed on the generator whole perimeter is of at least 1 meter.



WARNING

In the generator upper part, the exhaust pipe of the engine exhaust gases is situated, which mustn't for any reason be obstructed, and which, when the generator is operating, reaches very high temperatures. It is therefore necessary to foresee, also in the upper part, a sufficient free space for allowing the usual release of the exhaust gases and for preventing any possible contact with foreign bodies, because of a real combustion risk.



NOTE

Dimensions are expressed in mm.

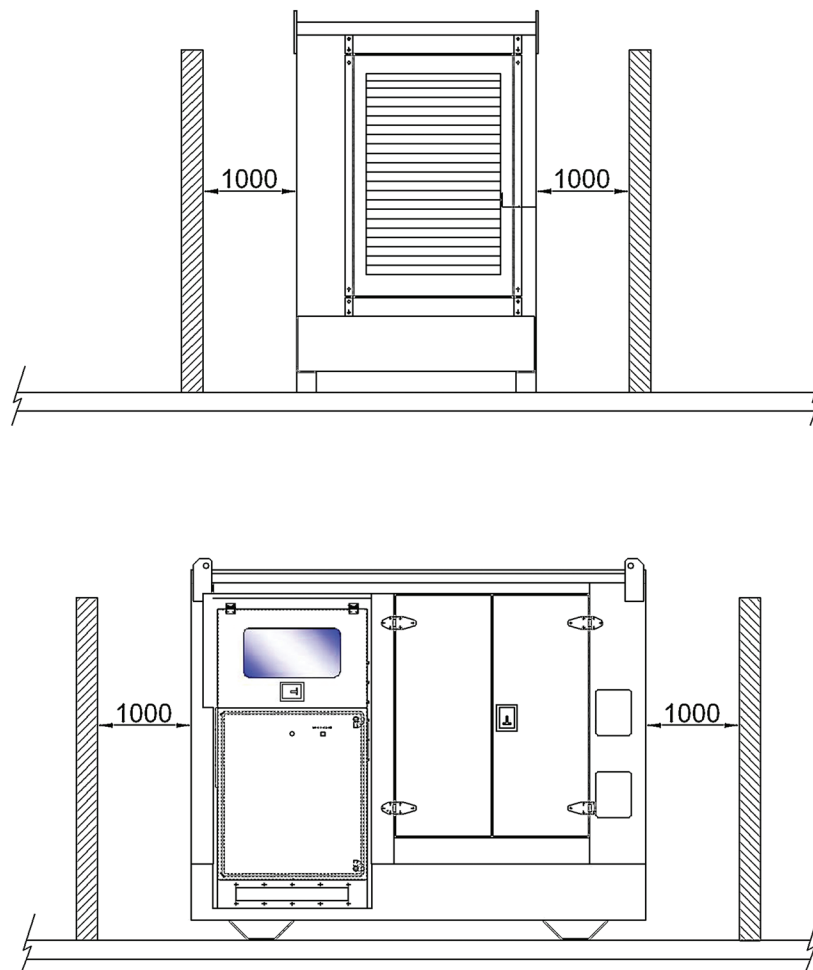

Figure 5.1 - Minimum distances to be observed during the generator installation

5.4.2 SWITCH ON THE BATTERIES SWITCH

Before proceeding to carry out the generator positioning, switch ON the batteries switch, as here following described:

- 1) Open the access door to the engine (see Figure 5.2/3), situated on the front part, by acting on the relevant handle (1), after having removed the locking padlock and switch ON the battery switch (2).

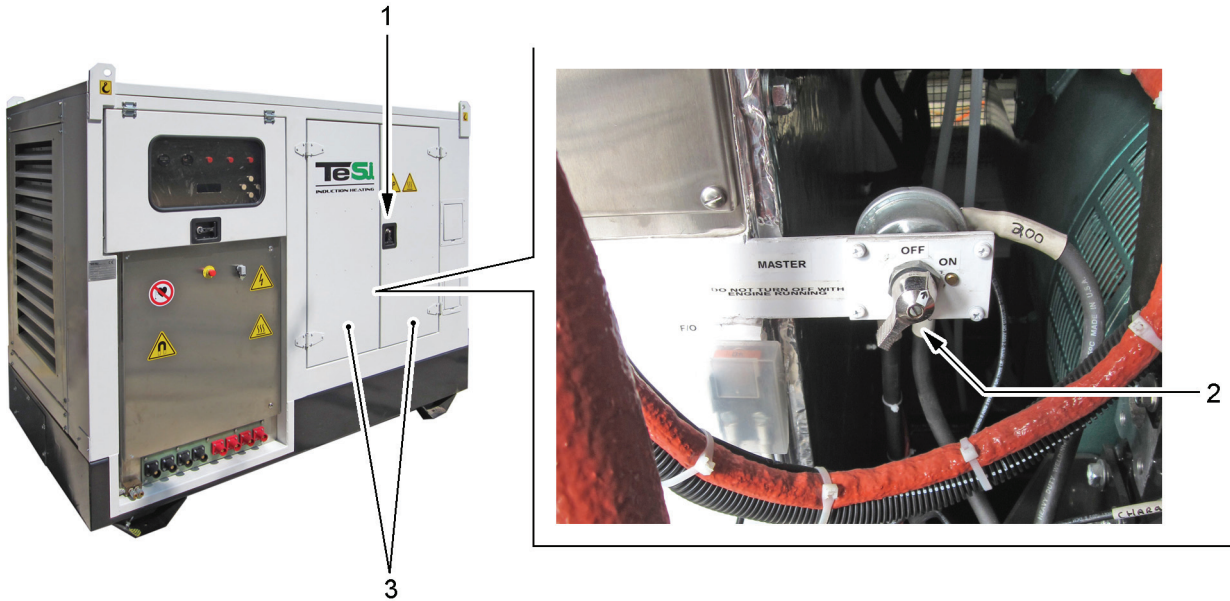

Figure 5.2 - Switch ON the batteries switch

5.4.3 POSITIONING OF THE INDUCTION HEATING GENERATOR IHG 120CU

Besides being possible to position, and then to use, the Induction Heating Generator IHG 120CU installed on suitable motor vehicles (self-propelled motor vehicles belonging to the Customer), having an adequate capacity for supporting, during use, the generator, the coil and the relevant power cables, in some particular cases the Induction Heating Generator IHG 120CU can also be positioned and used in indoor ambients; in this last case, it will be necessary to provide a proper intake for the exhaust gases produced by the operation of the generator engine, by fully observing the relevant rules in force in the country where the generator itself is used.



NOTE

The positioning of the generator on motor vehicles belonging to the Customer shall be carried out by fully observing the possibly existing relevant rules in force, and, anyway, always by providing to adequately fasten the generator to the motor vehicle structure by means of slings, ropes, tie rods etc., in order to prevent any sudden and unexpected side skids of the load.

As far as the positioning of the coils to the motor vehicle mechanical arm is concerned, also that operation must be performed in full observance of the reported instructions, and, anyway, still and exclusively by qualified and properly trained personnel.



CAUTION

The Induction Heating Generator IHG 120CU can operate on very steep slopes, up to a maximum of 40° (see Figure 5.3).

For mobile use on very sloping terrains, possibly place the Induction Heating Generator IHG 120CU crosswise with respect to the vehicle used for its transport.

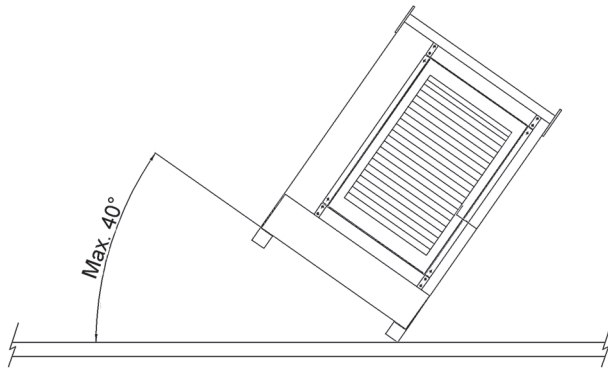

a. Front side max longitudinal gradient

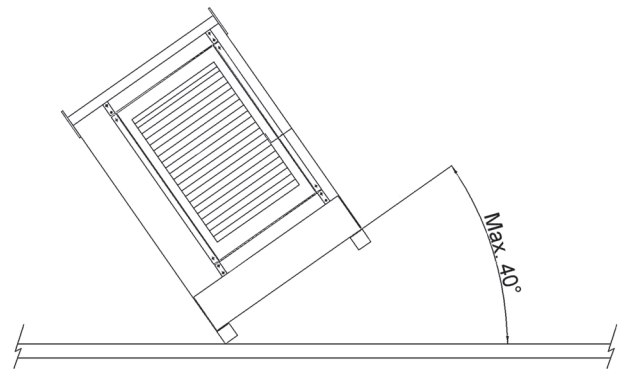

b. Rear side max longitudinal gradient

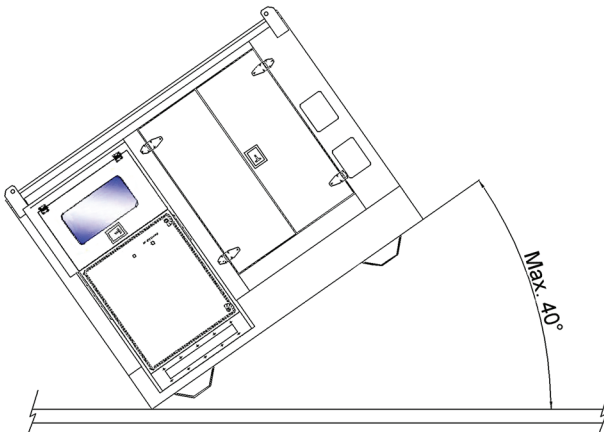

c. Left side max transversal gradient

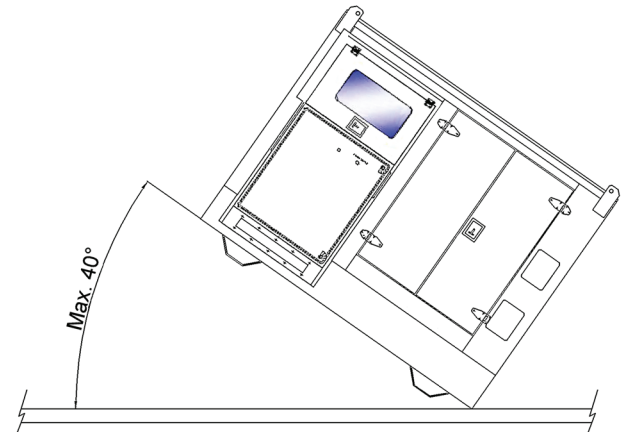

d. Right side max transversal gradient

Figure 5.3 - Max longitudinal and transversal gradients when using the Induction Heating Generator IHG 120CU

In order to get an indication about the values referred to the weights of generator, coils and power cables, for correctly defining the most suitable motor vehicle to be used, reference shall be made to Table 4.1.

**NOTE**

In case of any doubt about the weights to be supported, please contact TeSi s.r.l. Customer Service.

Independently of the motor vehicle used, it will be necessary to consider the generator and the coil as a single unit, and, therefore, to foresee for their handling a motor vehicle capable to reach the work site and then to easily move the coil onto the pipes to be treated.

The motor vehicle shall anyway be equipped with a mechanical arm (properly dimensioned for the used coil), capable to move the coil, by using the purposed belts (supplied on delivery), onto the pipe and to allow the execution of all the required operations.

**NOTE**

In order to facilitate the coil operations through the motor vehicle mechanical arm, it is recommended to use a purposed remote control.

**NOTE**

In order to facilitate all the required operations, the Induction Heating Generators IHG 120CU designed by TeSi s.r.l. are equipped with a remote control, for controlling the start and stop of the heating cycle and the emergency stop.

5.4.4 PRELIMINARY OPERATIONS TO BE CARRIED OUT ON THE GENERATOR

Before proceeding to start the generator, it will be necessary to carry out the following preliminary operations:

- check for the engine oil correct level (see Figure 5.4a) (see Paragraph 7.5.6);
- check for the engine coolant correct level (see Figure 5.4b) (see Paragraph 7.5.7);
- refuelling (see Figure 5.4c).

**NOTE**

In order to get more detailed information, reference shall be made to the engine "Owners Manual - QSB4.5 and 6.7", delivered by TeSi s.r.l. as a Joined Publication to this manual.

**WARNING**

Refuelling must be always carried out by absence of free flames, and during that operation it is absolutely forbidden to smoke.

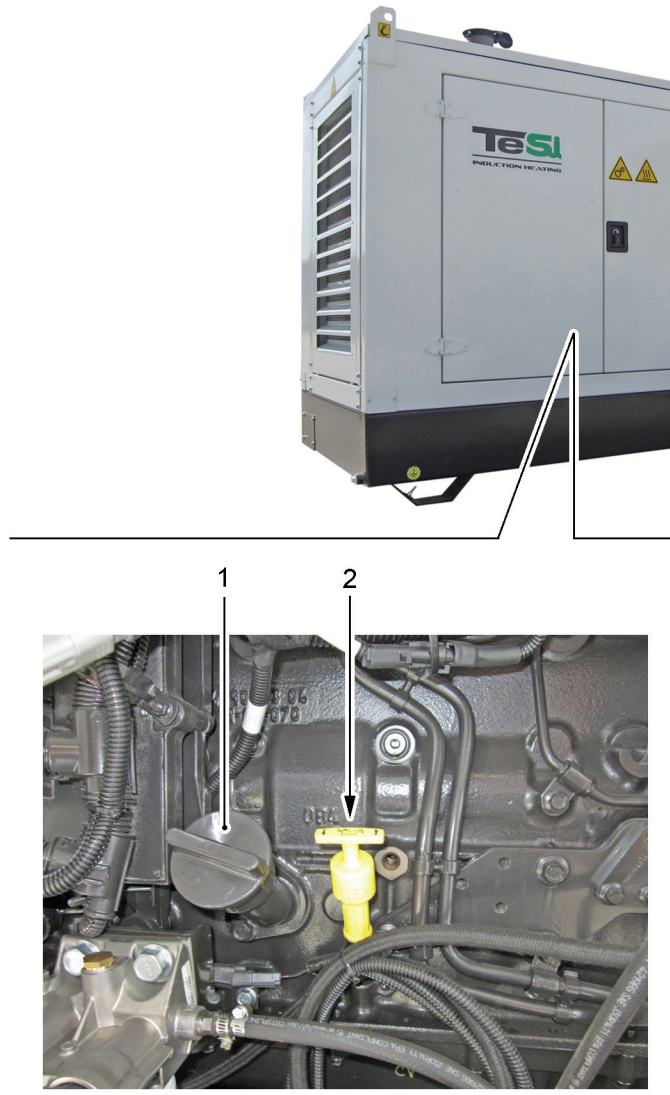

a. Engine oil correct level check

LEGEND

- 1 - Engine oil filler cap
- 2 - Engine oil level dipstick

*Figure 5.4 - Preliminary operations to be carried out on the generator
(Sheet 1 of 2)*



LEGEND

- 3 - Coolant filler cap
- 4 - Coolant level inspection window
- 5 - Access door to the filler cap
- 6 - Fuel filler cap

b. Engine coolant correct level check

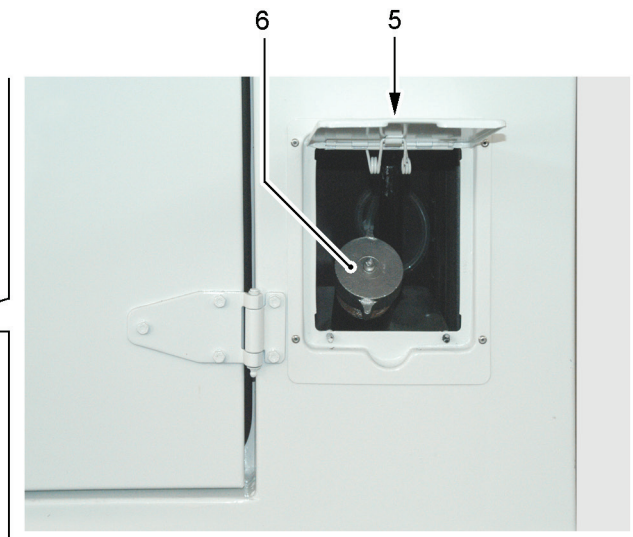

c. Refuelling

Figure 5.4 - Preliminary operations to be carried out on the generator
(Sheet 2 of 2)

5.4.5 ELECTRIC CONNECTIONS BETWEEN GENERATOR AND COIL

The generator (see Figure 5.5/1) and the coil (8) for heating the pipes must be connected the one to the other through purposed cables (5), which are also provided with power connectors (4) and (9), differently coloured (red and black), in order to make their use easier.

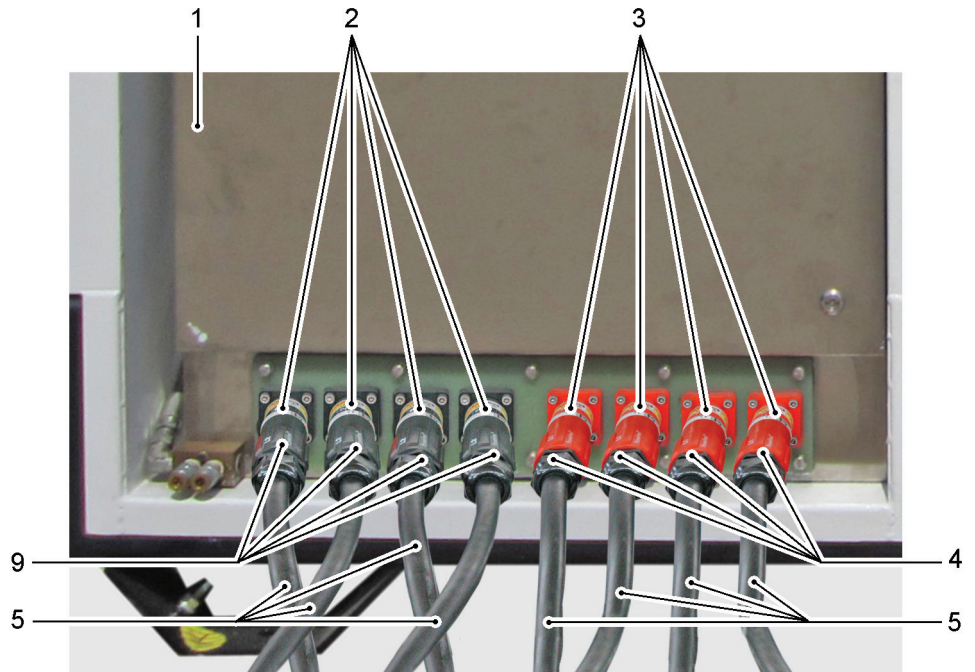

LEGEND

- 1 - Generator
- 2 - Power red connectors (on the generator)
- 3 - Power black connectors (on the generator)
- 4 - Power black connectors (on the cables)
- 5 - Power cables
- 6 - Power red connectors (on the coil)
- 7 - Power black connectors (on the coil)
- 8 - Coil
- 9 - Power red connectors (on the cables)

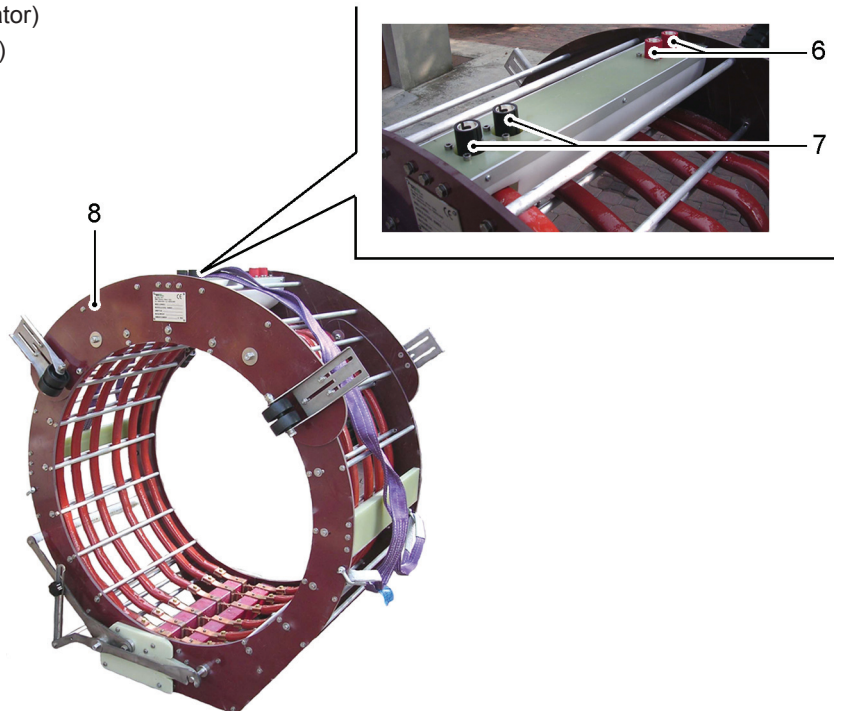



Figure 5.5 - Electric connections between coil and generator

In order to realize the electric connection between the coil (8) and the generator (1), which foresees the use of two or four power cables (5), proceed as here following specified:

	<p>NOTE Even if on the generator eight power connectors are foreseen, the electric connection with the coil is realized by using at most four power connectors (two red and two black ones). The other remaining power connectors keep available for being used in case a possible failure to the power connectors presently used should occur.</p>
---	--



	<p>WARNING The connections between generator and coil through the power cables can only and exclusively take place by turned off generator.</p>
---	--

- connect the power connectors (4) and (9) of the relevant cables (5) to the respective power connectors (3) and (2) situated on the generator (1), by observing the modalities reported in Paragraph 5.4.5.1;
- connect the power connectors situated on the other end of cables (5) to the respective power connectors (7) and (6) situated on the coil (8), by observing the modalities reported in Paragraph 5.4.5.1..

	<p>PROHIBITION For no reason carry out the disconnection of the power cables during the heating cycle.</p>
---	---

	<p>WARNING The connections between generator and coil must take place between power connectors of the same colour (red with red ones and black with black ones).</p>
---	---

	<p>NOTE As far as the disconnection of the power cables from the generator and from the coil, strictly observe the instructions reported in Paragraph 5.4.5.2.</p>
---	---

	<p>WARNING It is suggested to braid the power cables, in order to eliminate the electromagnetic field.</p>
	

	<p>WARNING Make sure the power cables (see Figure 5.6) connecting the generator to the coil are correctly stretched, in order to prevent them from creating any rings.</p>
---	---

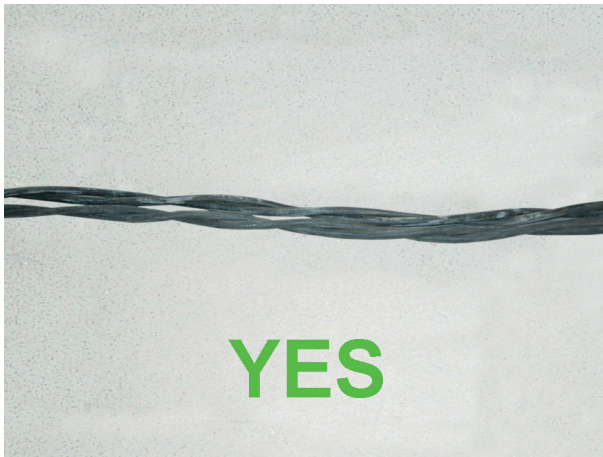

Figure 5.6 - Arrangement of the power cables

5.4.5.1 Coupling of the power connectors



WARNING

The connections between generator and coil through the power cables can only and exclusively take place by turned off generator.

In order to carry out a correct coupling of the power connectors, strictly observe the instructions here following reported:

- get the arrow showing the indication “PUSH”, situated on the power connector (see Figure 5.7/1) of the concerned cable, aligned with the respective arrow present on the power connector (3) of either the generator or the coil;

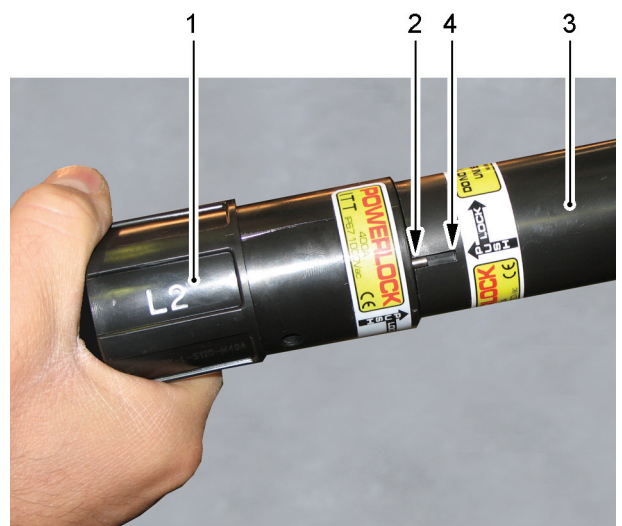
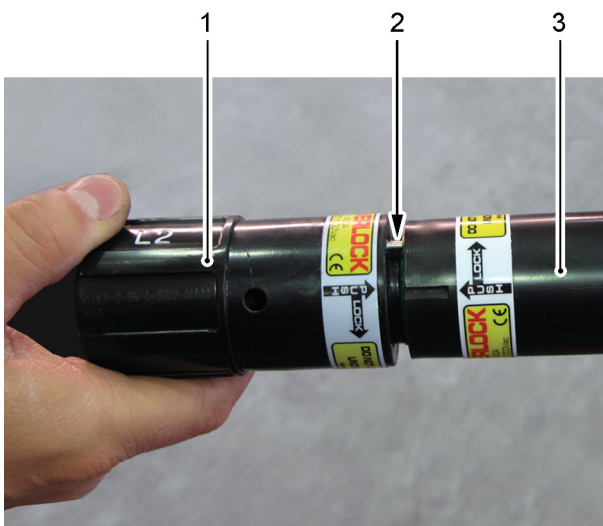

LEGEND

- 1 - Power connector (on the cable)
- 2 - Lockpin
- 3 - Power connector (either on the generator or on the coil)
- 4 - Slot

Figure 5.7 - Coupling of the power connectors

- deeply push the power connector (1), in such a way that the lockpin (2) gets hidden inside the same one;
- turn the power connector (1), by following the indication “LOCK” reported on the arrow (clockwise), in such a way that the lockpin (2), getting out from the relevant seat, get engaged inside the slot (4) machined on the power connector (3) of either the generator or the coil; now the power connector (1) of the concerned cable results to be perfectly connected.

5.4.5.2 Uncoupling of the power connectors

	<p>PROHIBITION For no reason carry out the disconnection of the power cables during the heating cycle.</p>
---	---

In order to carry out a correct uncoupling of the power connectors, strictly observe the instructions here following reported:

- hold the power connector (see Figure 5.8/1) of the concerned cable and position inside the slot, machined on the power connector (4) of either the generator or the coil, the tool (3) supplied on delivery;
- by using tool (3), release the lockpin (2) from the slot, and simultaneously turn counter-clockwise the power connector (1) of the concerned cable;

	<p>NOTE Shouldn't the tool supplied on delivery be available, use a suitable screwdriver, in order to release the lockpin from the slot machined on the power connector of either the generator or the coil.</p>
---	---

- Disconnect the power connector (1) from the respective power connector (4) of either the generator or the coil.

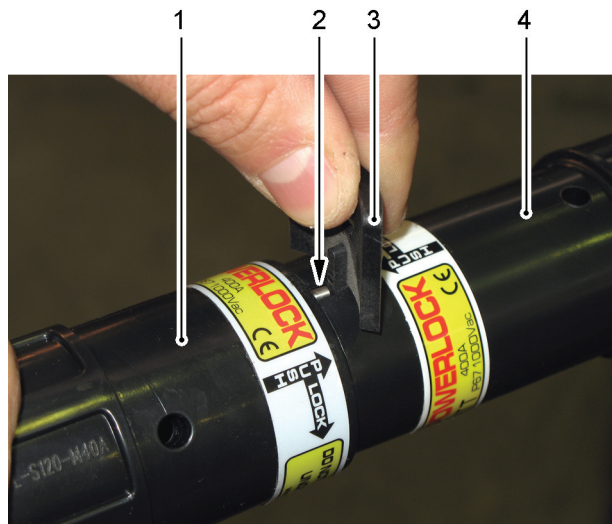

LEGEND

- 1 - Power connector (on the cable)
- 2 - Lockpin
- 3 - Tool (supplied on delivery)
- 4 - Power connector (either on the generator or on the coil)

Figure 5.8 - Uncoupling of the power connectors

5.4.6 GENERATOR GROUNDING

	<p>WARNING It is obligatory to realize the grounding of the generator, together with the relevant pipe to be treated.</p>
--	--

Perform the generator grounding, by carrying out the here following described procedures:

- connect a cable of adequate length and with a section of at least 120 mm², to the threaded pin for the generator grounding (see Figure 5.9), through a nut and relevant washer. Such point is countermarked by a plate showing the grounding specific symbol;
- connect the other end of the cable to the pipe to be treated.

	<p>NOTE Before performing the grounding, eliminate any possible oxidation signs from the connections' contact surface.</p>
--	---

	<p>NOTE The cable for the generator grounding isn't included within the delivery supplied by TeSi s.r.l..</p>
--	--

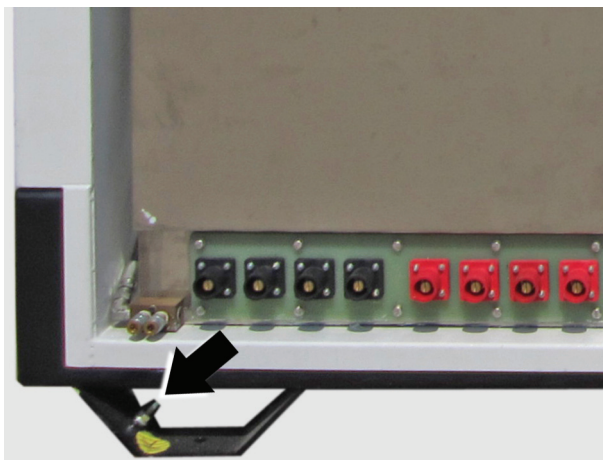

a. Threaded pin for the grounding
(on the generator)

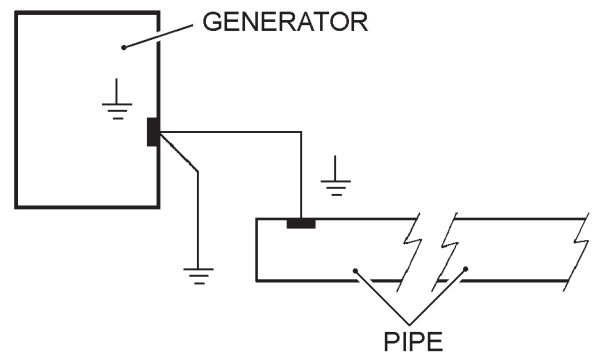

b. Grounding connections

Figure 5.9 - Generator grounding

5.4.7 REMOTE CONTROL ELECTRIC CONNECTION

Get the remote control mobile connector (see Figure 5.10/2) connected to the relevant fixed connector (3), situated on the command and control panel (1).



NOTE

The Induction Heating Generator IHG 120CU only operates, provided that the remote control is connected to the purposed connector, situated on the command and control panel.

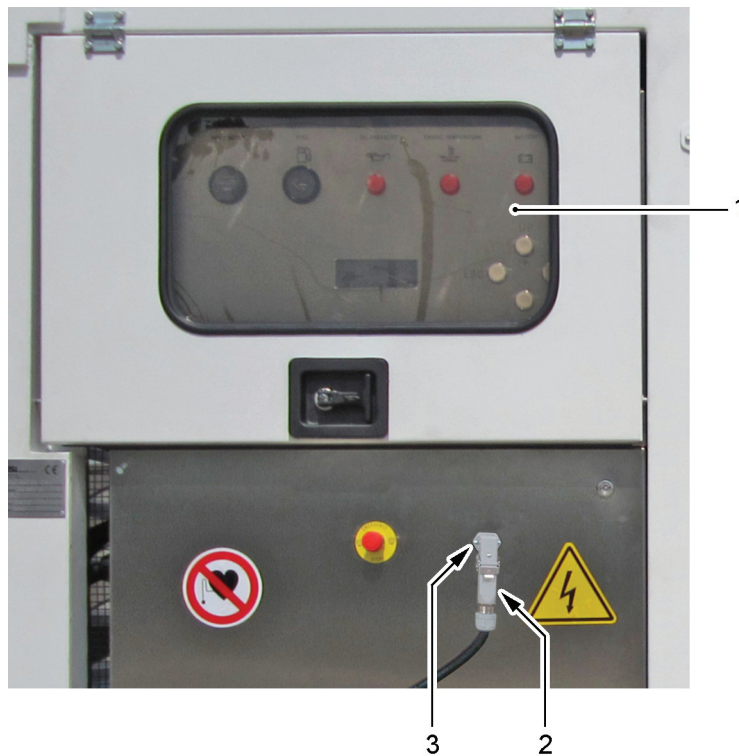

LEGEND

- 1 - Command and control panel
- 2 - Remote control mobile connector
- 3 - Connector for remote control connection

Figure 5.10 - Remote control electric connection

Chapter

6

USE

6.1 GENERAL WARNINGS



WARNING

The majority of the accidents on the work place are due to inobservance of the most elementary safety rules. It is absolutely necessary that anybody operating on the Induction Heating Generator IHG 120CU perfectly knows and strictly observes the rules reported both in this publication (see Chapter 3 “Safety Rules”) and on the warning plates.



CAUTION

Before starting up the Induction Heating Generator IHG 120CU, it is imperative to have carefully learned all the information reported in Chapter 2 “General Technical Information” and in Chapter 5 “Installation”.



CAUTION

Should any discrepancies between the operation described in this Chapter and the real operation of the Induction Heating Generator IHG 120CU be noticed, please contact TeSi s.r.l. in order to get the necessary explanations.



CAUTION

TeSi s.r.l. aren't responsible for any damages either to the Induction Heating Generator IHG 120CU or to any of its parts, if the indications reported in this manual aren't fully observed.

6.2 COMMANDS AND CONTROLS



6.2.1 GENERAL







In this Paragraph, the commands and controls present on the Induction Heating Generator IHG 120CU are described.

6.2.2 COMMAND AND CONTROL PANEL

In Figure 6.1 the front view of the command and control panel is shown, while in Table 6.1 the commands and controls situated on the panel itself are described.

Table 6.1 - Commands and controls situated on the command and control panel

POS.	PLATE	TYPE	FUNCTION
1	HOUR METER 	Indicator	It shows the engine operating hours
2		Indicator	It shows the level of the fuel present inside the tank
3		Red warning light	(If on), it signals the engine oil low pressure

POS.	PLATE	TYPE	FUNCTION
4		Red warning light	(If on), it signals the engine high temperature
5		Red warning light	(If on), it signals the engine alternator low charge voltage
6		White pushbutton	If pressed, it allows to move from one page to another one inside the menu, in ascending direction (UP). If pressed for at least 3 seconds it allows to set the output power of generator (=alternator output current). If pressed together with the pushbutton of pos. 8 for at least 3 seconds, it allows to accede to the machine parameters' setting menu
7		White pushbutton	If pressed while you are in the parameters setting menu you confirm the setting
8		White pushbutton	If pressed, it allows to move from one page to another one inside the menu, in descending direction (DOWN). If pressed for at least 3 seconds it allows to set the output power of generator (=alternator output current). If pressed together with the pushbutton of pos. 6 for at least 3 seconds, it allows to accede to the machine parameters' setting menu
9		White pushbutton	If pressed you ESCAPE from the machine parameters' setting menu
10	-	Ignition key	It allows to start up the engine
11		Connector	It allows to realize the remote control connection
12	EMERGENCY STOP	Red mush-room-head pushbutton	When pressed, it causes: <ul style="list-style-type: none"> - the immediate engine stop - the immediate shut off of the power supply to the coils
13	STOP	Black pushbutton	When pressed, it causes the heating cycle in progress to stop
14	USB (Optional)	USB type socket	Permits connecting a flash memory for downloading LOGGER data from the generator and updating machine firmware

POS.	PLATE	TYPE	FUNCTION
15	-	Display	<p>It allows to control the generator processes. Its functions can be summarized in the following way:</p> <ul style="list-style-type: none"> - monitoring of the parameters relevant to the heating function - monitoring of the generator state and visualization of the possible failures - setting of the generator working and use parameters

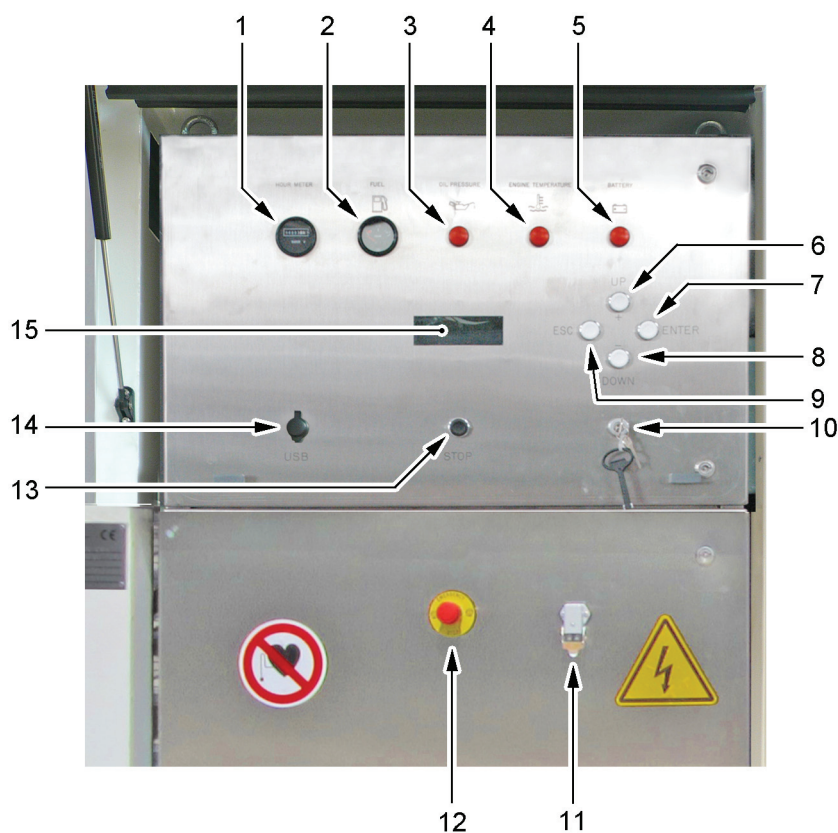

Figure 6.1 - Commands and controls of the command and control panel

6.2.2.1 Display

As already reported in Table 6.1, the display allows to control the processes relevant to the generator. The functions here following enlisted and later on treated more in detail, are:

- monitoring of the parameters relevant to the heating function and visualization of the engine working parameters (see Figure 6.2);
- monitoring of the generator state and visualization of the possible failures;
- setting of the generator working and use parameters.

a) **Monitoring of the parameters relevant to the heating function and visualization of the engine working parameters**



Figure 6.2 - Visualization menu of the parameters relevant to the heating function and to the engine working

 **NOTE**
If the heating cycle wasn't started, the display of the values relevant to the voltage, current and power variables will result to be zero, and the Power Factor will read "*****".

By singularly pressing the pushbuttons UP and DOWN, it is possible to flow the list of all the parameter displays. Having a circular structure, the parameters' list sequence is bidirectional.

b) **Monitoring of the generator state and visualization of the possible failures**

It allows to monitor the generator state during its operation, by visualizing on the DISPLAY the failure or anomaly found out.

The list of the failures, which can be directly visualized on the DISPLAY, is reported in Chapter 8 "Diagnostics".

c) Setting of the generator working and use parameters

The menu relevant to the look-up and to the setting of the generator parameters, which can be visualized on the DISPLAY, is reported in the flow diagram of Figure 6.3.

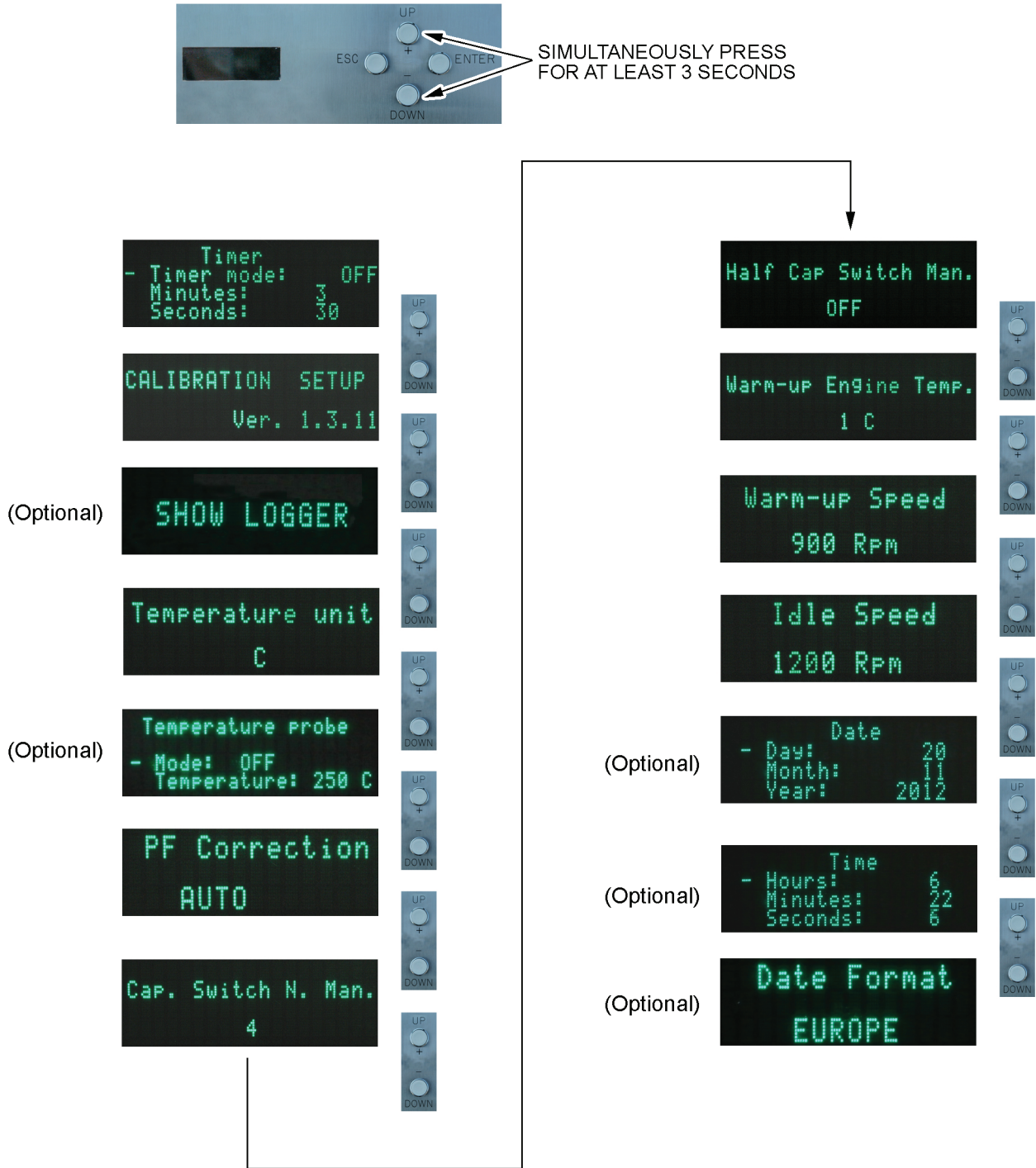

Figure 6.3 - Visualization menu of the generator working and use parameters setting (flow diagram)

	<p>CAUTION The access to that menu is EXCLUSIVELY possible when the heating cycle isn't running and is ONLY recommended to skilled personnel.</p>
---	--

	<p>CAUTION TeSi s.r.l. decline every responsibility for damages or failures due to incompetence or negligence.</p>
---	---

The access to the generator parameters' setting menu is possible by simultaneously pressing the pushbuttons UP and DOWN for at least 3 seconds. After that, the first display with the first parameter will appear.

By singularly pressing the pushbuttons UP and DOWN, it is possible to flow the list of all the generator parameters, and, with them, immediately the value presently set.

Having a circular structure, the parameters' list sequence is bidirectional.

1) Parameters' list

The list with the relevant parameters is illustrated in the flow diagram of Figure 6.3 and reported in Table 6.2.

Table 6.2 - List of the parameters to be visualized on the display

PARAMETER	DESCRIPTION	PARAMETER RANGE/STEP	DEFAULT VALUE
Timer mode	When this parameter is turned ON the heating cycle will automatically STOP after the time set in this page.	ON - OFF	OFF
Calibration Setup	Access to the calibration menu. The access is only and exclusively allowed to the technicians of the TeSi s.r.l. "After-Sales Technical Service".	-	-
SHOW LOGGER (Optional)	Access to the logger. Press Enter to entry into the logger.	-	-
Temperature unit	With this parameter you can choose between Celsius and Fahrenheit temperature scale. In order to change this parameter it could be necessary to enter the password.	°C - °F	°C
Temperature Probe (Optional)	When the parameter "Mode" is ON the heating cycle will automatically STOP when the temperature is reached. In order to change these parameters it could be necessary to enter the password.	ON - OFF	OFF

PARAMETER	DESCRIPTION	PARAMETER RANGE/STEP	DEFAULT VALUE
PF Correction	<p>Selection of the system operating mode for the “PF” automatic correction (see Paragraph 6.4.5).</p> <p>When set on “AUTO”, the generator, during subsequent heating cycles, calculates the number of capacitors for keeping the “PF” as near as possible to 1.0.</p> <p>When the parameter is set on “MAN”, during the heating cycle the number or capacitor banks indicated in parameter “Cap. Switch N. Man” is inserted into the circuit + the half capacitor bank if the “Half Cap Switch Man” is ON.</p> <p>In order to change this parameter it could be necessary to enter the password.</p>	MAN - AUTO	AUTO
Cap. Switch N. Man	<p>Setting of the capacitor bank number to be inserted in the circuit with “PF Correction” parameter set on “MAN” (see Paragraph 6.4.5).</p> <p>In order to change this parameter it could be necessary to enter the password.</p>	1 - 11	4
Half Cap Switch Man.	<p>Setting of the half capacitor bank to be inserted in the circuit with “PF Correction” parameter set on “MAN” (see Paragraph 6.4.5).</p> <p>In order to change this parameter it could be necessary to enter the password.</p>	ON - OFF	OFF
Warm-up Engine Temp.	<p>With this parameter it is possible to set the temperature below which heating cycle is not enable and engine rotates at the speed set by the parameter “Warm-up Speed”.</p> <p>In order to change this parameter it could be necessary to enter the password.</p>	-50° C - 100° C	1° C
Warm-up Speed	<p>With this parameter it is possible to set the engine speed in order to bring it to the temperature defined by the parameter “Warm-up Engine Temp.”</p> <p>In order to change this parameter it could be necessary to enter the password.</p>	500 - 5000	900
Idle Speed	<p>With this parameter it is possible to set the engine speed when the heating cycle is not active.</p> <p>In order to change this parameter it could be necessary to enter the password.</p>	500 - 5000	1000
Date (Optional)	<p>With these parameters it is possible to set the current date.</p> <p>In order to change these parameters it could be necessary to enter the password.</p>	-	-

PARAMETER	DESCRIPTION	PARAMETER RANGE/STEP	DEFAULT VALUE
Time (Optional)	With these parameters it is possible to set the current time. In order to change these parameters it could be necessary to enter the password.	-	-
Date Format (Optional)	With these parameters it is possible to set the date format: - EUROPE, day/month/year; - USA, month/day/year; - JAPAN, year/month/day. In order to change this parameter it could be necessary to enter the password	EUROPE USA JAPAN	EUROPE

2) Display and setting of the value of a parameter

In order to modify from the display the value of a parameter of the setting menu, proceed as here following specified, by using like a reference also the flow diagram illustrated in Figure 6.4:

- select the parameter to be modified and press the “ENTER” pushbutton; the system gets predisposed to modify the parameter value. By pressing the “ESC” pushbutton, it is possible to leave the menu and the display gets back to the operative mode;
- modify the parameter value by using the two pushbuttons UP and DOWN;
- when the parameter wished value is reached, press the “ENTER” pushbutton.
- press the pushbutton ESC to leave generator parameters’ setting menu and back to operative mode.

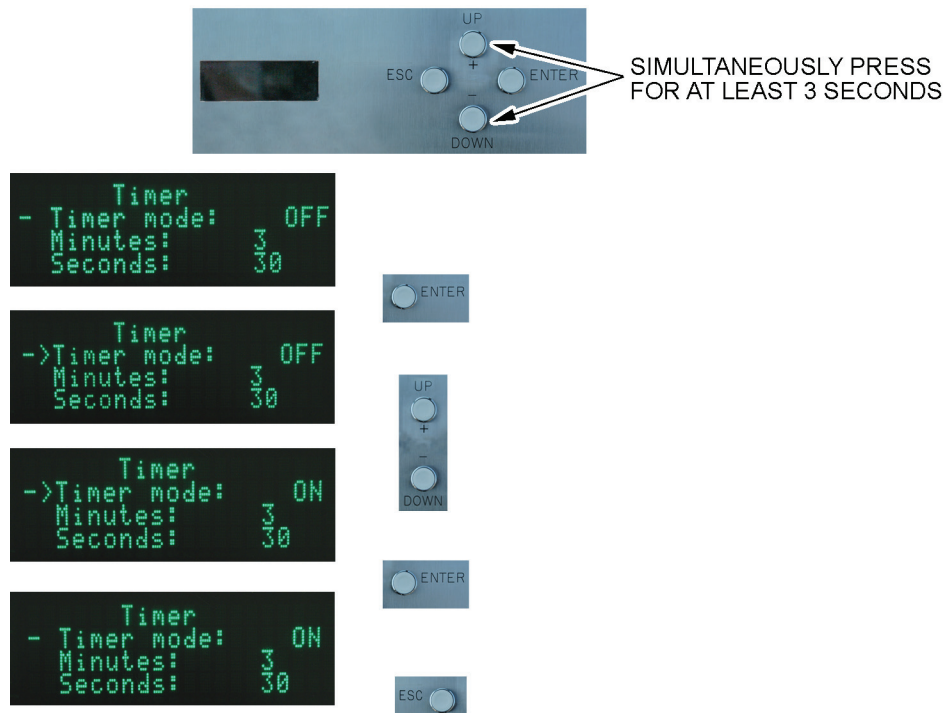

Figure 6.4 - Visualization and setting menu of the value of a parameter (flow diagram)

3) Display and setting of the value of a password protected parameter

Some parameters may be protected by a password. In order to modify the value of a parameter of the setting menu from the display, proceed as here following specified, by using like a reference also the flow diagram illustrated in Figure 6.5:

- select the parameter to be modified and press the “ENTER” pushbutton;
- the system will ask to enter the password;
- insert the password and press the “ENTER” pushbutton; the system gets predisposed to modify the parameter value. By pressing the “ESC” pushbutton, it is possible to leave the menu and the display gets back to the operative mode;
- modify the parameter value by using the two pushbuttons UP and DOWN;
- when the parameter wished value is reached, press the “ENTER” pushbutton;
- press the pushbutton “ESC” to leave generator parameters’ setting menu and back to operative mode.



Figure 6.5 - Visualization and setting of the value of a password protected parameter (flow diagram)

6.2.3 REMOTE CONTROL

In Figure 6.6 the front view of the remote control is shown, while in Table 6.3 the commands and controls present on the remote control itself are described.

Table 6.3 - Commands and controls present on the remote control

POS.	PLATE	TYPE	FUNCTION
1	-	Connector	It allows to realize the connection with the connector situated on the command and control panel
2	START	Pushbutton	When pressed, it causes the heating cycle to start.
3	-	Red mush-room-head pushbutton	When pressed, it causes: <ul style="list-style-type: none"> - the immediate engine stop - the immediate shut off of the power supply to the coils
4	-	Green warning light	(If on), it signals that the heating cycle is in progress.
5	STOP	Pushbutton	When pressed, it causes the heating cycle in progress to stop

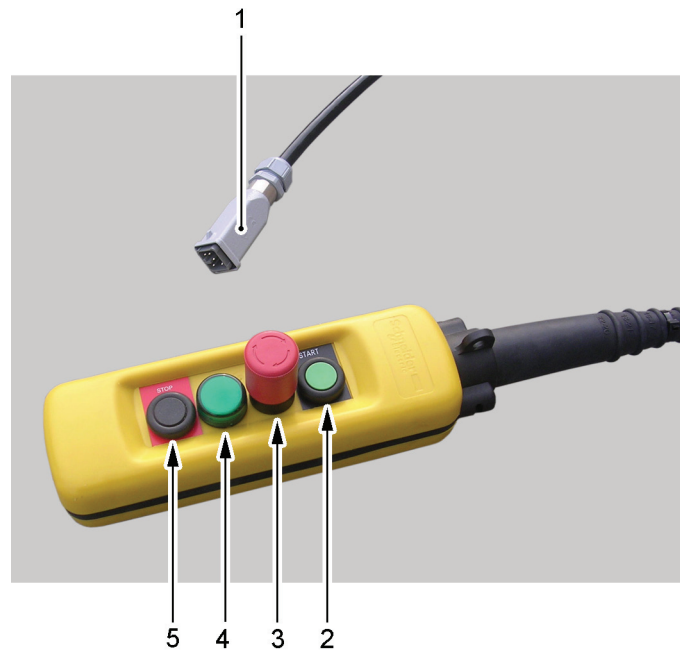

Figure 6.6 - Commands and controls present on the remote control

	<p>NOTE The Induction Heating Generator IHG 120CU only operates, provided that the remote control is connected to the purposed connector, situated on the command and control panel.</p>
---	---

6.3 PRELIMINARY CHECKS

After having complied with the instructions reported in Chapter 5 “Installation”, and, anyway, still by Induction Heating Generator IHG 120CU powered off, it will be necessary to carry out the here following reported further checks, in order to prevent any possible malfunctions or damages to the generator itself from taking place:

- visually check that the air intake grate (see Figure 6.7/1) isn't obstructed. If it is, carefully clean it (see Paragraph 7.5.1);
- visually check that the air exhaust grate (see Figure 6.7/2) isn't obstructed. If it is, carefully clean it (see Paragraph 7.5.2);



PROHIBITION

Never obstruct the air intake and exhaust grates, situated on the generator structure, which allow the cooling down of the structure inside, as well as the intake and the down flow of the hot air during engine operation.

An obstruction, even if only partial, would lead to a quick overheating of the generator inside and to the consequent, heavy damages.



LEGEND

- 1 - Air intake grate (left side)
- 2 - Air exhaust grate (right side)

Figure 6.7 - Air intake and exhaust grates

- visually check that the commands and controls (see Figure 6.8), situated on the command and control panel, are free from any dirt. If not so, carefully clean them (see Paragraph 7.5.4).



Figure 6.8 - Command and control panel

6.4 USE

	<p>CAUTION The Induction Heating Generator IHG 120CU can operate on very steep slopes, up to a maximum of 40° (see Figure 6.9). For mobile use on very sloping terrains, possibly place the Induction Heating Generator IHG 120CU crosswise with respect to the vehicle used for its transport.</p>
	<p>PROHIBITION Never open or remove the coils when the Induction Heating Generator IHG 120CU is in the heating cycle phase.</p>
	<p>PROHIBITION For no reason carry out the disconnection of the power cables during the heating cycle.</p>
	<p>WARNING Presence of high magnetic fields near the generator, the coil and the power cables realizing the connection between coil and generator.</p>
	<p>The most intensive presence of high magnetic fields can be found near the coil.</p>
	<p>People with pacemaker must pay attention and keep themselves at a proper distance. It is possible to have electromedical devices' failures.</p>

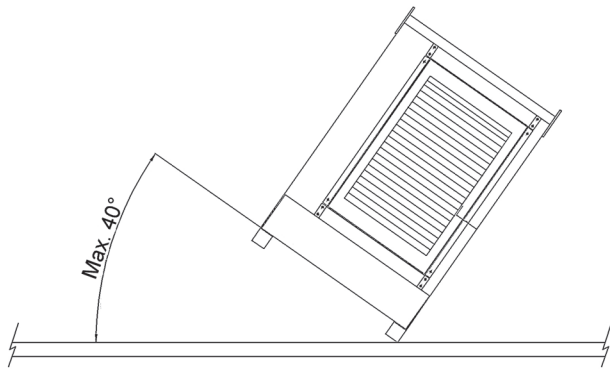

a. Front side max longitudinal gradient

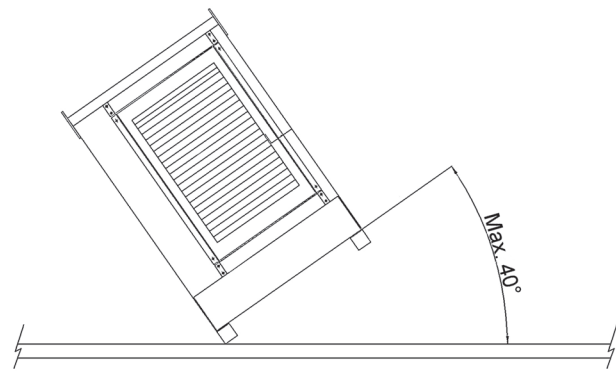

b. Rear side max longitudinal gradient

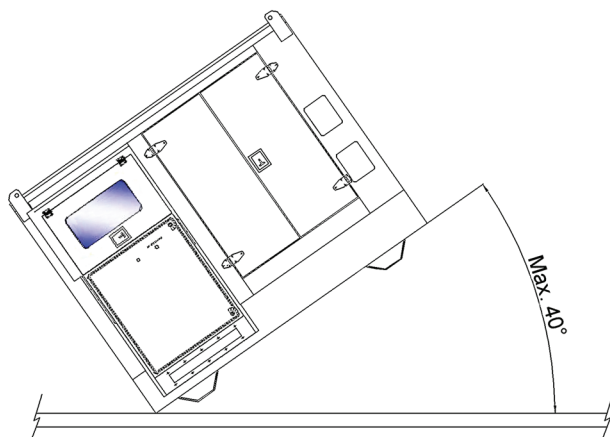

c. Left side max transversal gradient

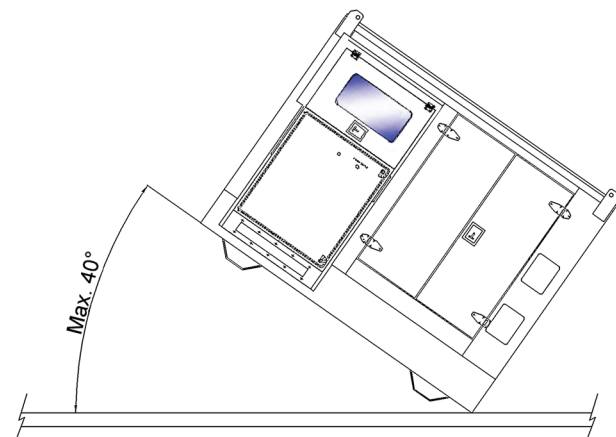

d. Right side max transversal gradient

Figure 6.9 - Max longitudinal and transversal gradients when using the Induction Heating Generator IHG 120CU

6.4.1 PRELIMINARY OPERATIONS TO BE CARRIED OUT BEFORE STARTING THE ENGINE

Proceed to power supply the generator, by carrying out the here following specified preliminary operations:

- 1) Open the access door to the engine (see Figure 6.10/3), situated on the front part, by acting on the relevant handle (1), after having removed the locking padlock and switch ON the battery switch (2).

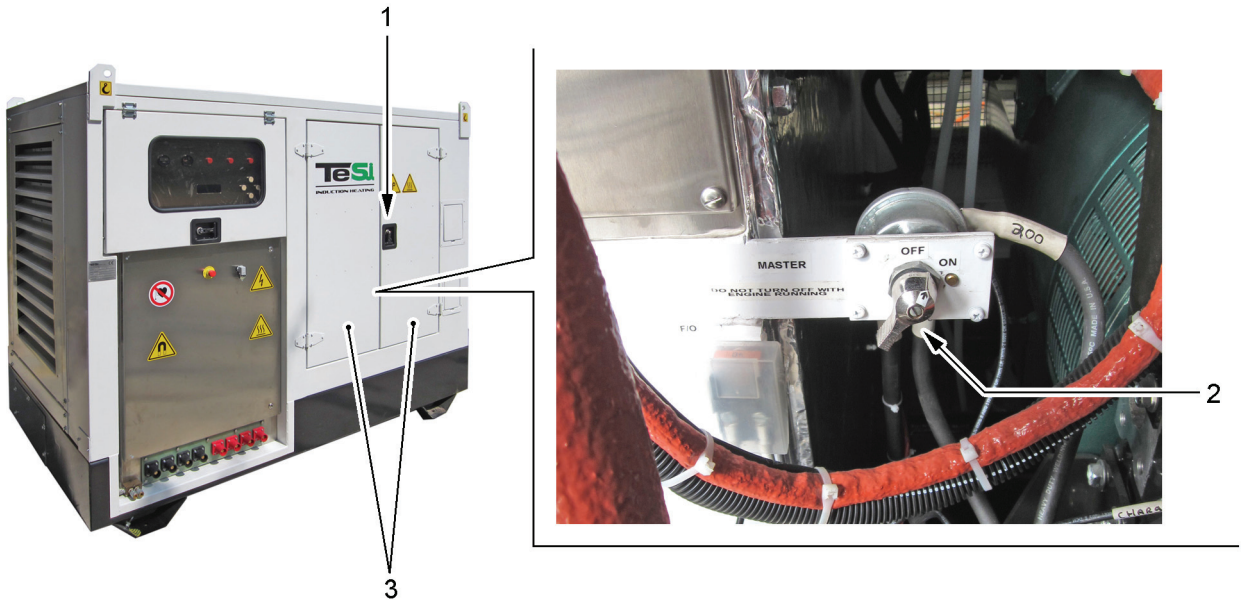

Figure 6.10 - Batteries switch

- 2) By acting on the relevant handle (see Figure 6.11/1), after having removed the locking padlock (if present), open the transparent hatch (2), provided for protecting the command and control panel.



Figure 6.11 - Transparent hatch opening and locking

- 3) Insert the key (see Figure 6.12/5) into the ignition commutator situated on the command and control panel (1) and turn it clockwise, up to notice the first click.

On the command and control panel (1), the following signalings light up:

- the engine alternator warning light (4);
- the display (2).

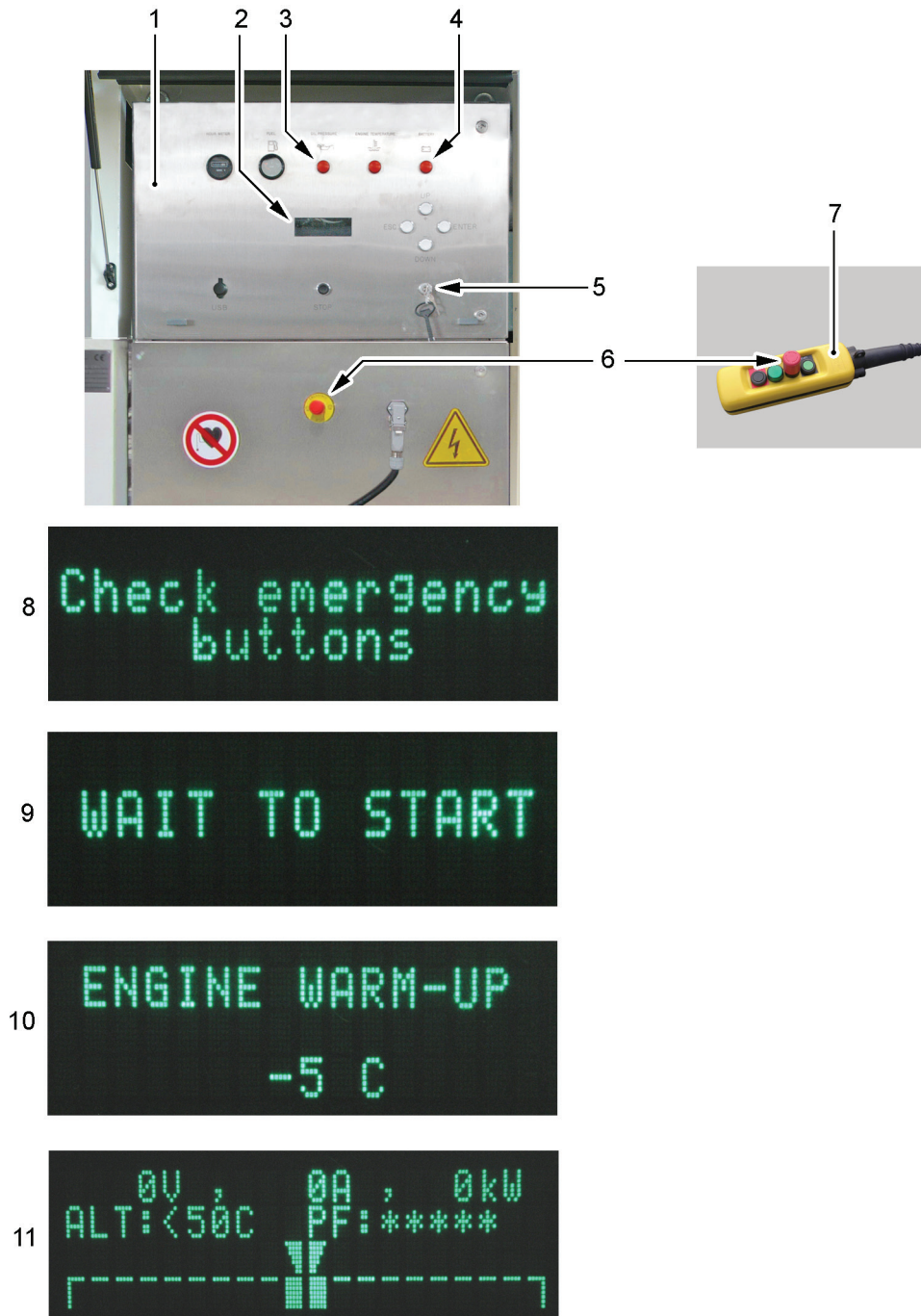

Figure 6.12 - Preliminary operations

- 4) The display will show the message **“Check emergency buttons”** (see Figure 6.12/8). Check that the **“EMERGENCY STOP”** (6) present on the command and control panel (1) and on the remote control (7), respectively, are not actuated.

**WARNING**

If the remote control (7) is not connected, the message “Check emergency buttons” remains on the display (1) and the engine cannot be started.

- 5) If the ambient temperature is cold the display will show the message **“WAIT TO START”** (see Figure 6.12/9). At the subsequent display it is possible to start the engine.
- 6) If the engine temperature is lower than the value set in the parameter **“Warm-up Engine Temp.”** the engine will rotate at the **“Warm-up Speed”** disabling the possibility of starting the heating cycle (see Figure 6.12/10).
- 7) After the previous step the display will show the page with the induction heating function parameters (see Figure 6.12/11).

6.4.2 ENGINE STARTING

Proceed to the engine starting, by carrying out the here following reported operations:

- 1) Perform the preliminary operations to be carried out before starting the engine, indicated in Paragraph 6.4.1.
- 2) Carry out the next steps a. ÷ c. only on the engine first starting, or anytime the pump is emptied. Otherwise, go directly to step 3):
 - a. Open the access door to the engine (see Figure 6.13/1), situated on the generator rear part, by acting on the relevant handle (2), after having removed the locking padlock.

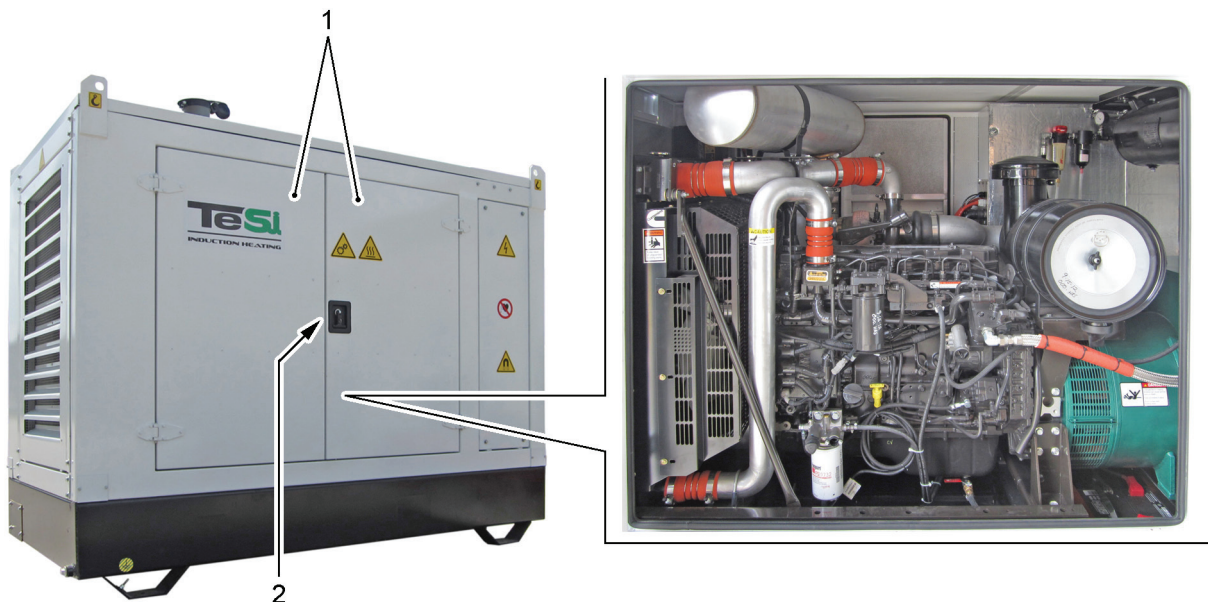

Figure 6.13 - Opening of the access door to the engine (rear part)

- b. Exert 4 or 5 manual pressures on the hand pump (see Figure 6.14) situated on the engine, in order to cause the fuel to return and to bleed the plant.

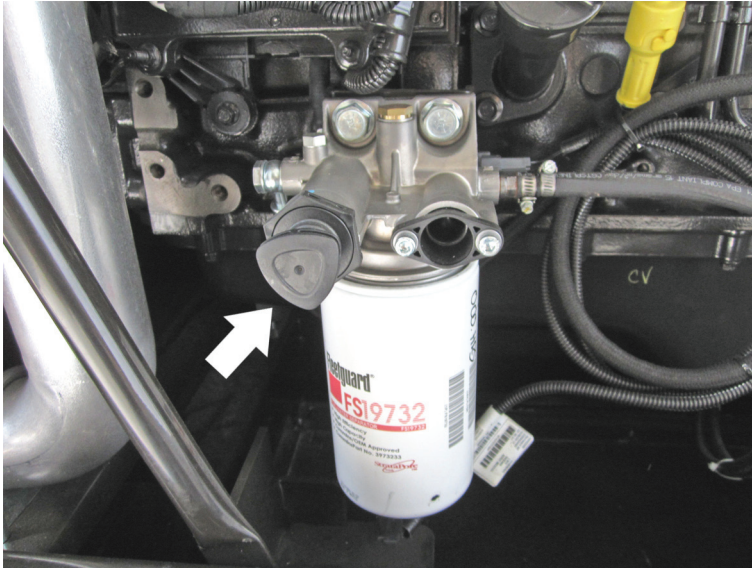

Figure 6.14 - Fuel scavenge hand pump

- c. Close the access door to the engine (see Figure 6.13), by acting on the handle (2) and lock it by means of the locking padlock.



NOTE

In order to get further information, reference shall be made to the engine “Owners Manual - QSB4.5 and 6.7”, delivered by TeSi s.r.l. as a Joined Publication to this manual.

- 3) Turn again the key (see Figure 6.12/5) clockwise and start the engine. By idle-running engine, the following signalings must get off:
- engine alternator warning light (4);
 - engine oil low warning light (3).



CAUTION

If the engine doesn't start, carry out the steps a. ÷ c. indicated at step 2).



NOTE

When the engine has been started, make sure that from the exhaust pipe terminal the exhaust gases get regularly out. If not so, immediately turn off the engine and provide to eliminate the found out anomaly (see Paragraph 7.5.5).

- 4) After having started up the generator, check that on the command and control panel (see Figure 6.12/1), no type of alarm message is displayed, particularly those coming from the engine control system, that signal:
- engine oil low pressure;
 - engine high temperature;
 - engine alternator low charge voltage.

**CAUTION**

Should one of the checks indicated at step 4) result to be beyond the preset limits, reference shall be made to the engine "Owners Manual - QSB4.5 and 6.7", delivered by TeSi s.r.l. as a Jointed Publication to this manual. If the anomaly persists, immediately contact the TeSi s.r.l. "After-Sales Technical Service".

6.4.3 SETTING OPERATIONS

6.4.3.1 General

Before that it is possible to use the Induction Heating Generator IHG 120CU for production purposes, it is necessary to carry out the here following indicated setting operations, consisting of:

- a) setting of the heating time;
- b) setting of the pipe temperature (optional);
- c) setting of the output power (= alternator output current).

**CAUTION**

All setting operations must be performed by idle-running engine.

6.4.3.2 Setting of the heating time

The Induction Heating Generator IHG 120CU is provided with a timer which, if actuated, permits automatically stopping the heating cycle when the preset time expires.

In order to set the heating time, proceed as here following specified, by using like a reference also the flow diagram illustrated in Figure 6.15:

- 1) From the operative mode page (1) press the pushbuttons UP and DOWN for at least 3 seconds;
- 2) From the TIMER page (2) set Timer mode = ON and the heating time. See paragraph 6.2.2.1c "Setting of the generator working and use parameters" to learn how modify working parameters. (Example Figure 6.15/3: Timer mode=ON, Minutes=5 and Seconds=0);
- 3) Press ESC button (4) to go back to the operative mode page (5). Now on the bottom left side there is the message "TIMER ON" that means the hating cycle will automatically stop after the set time.

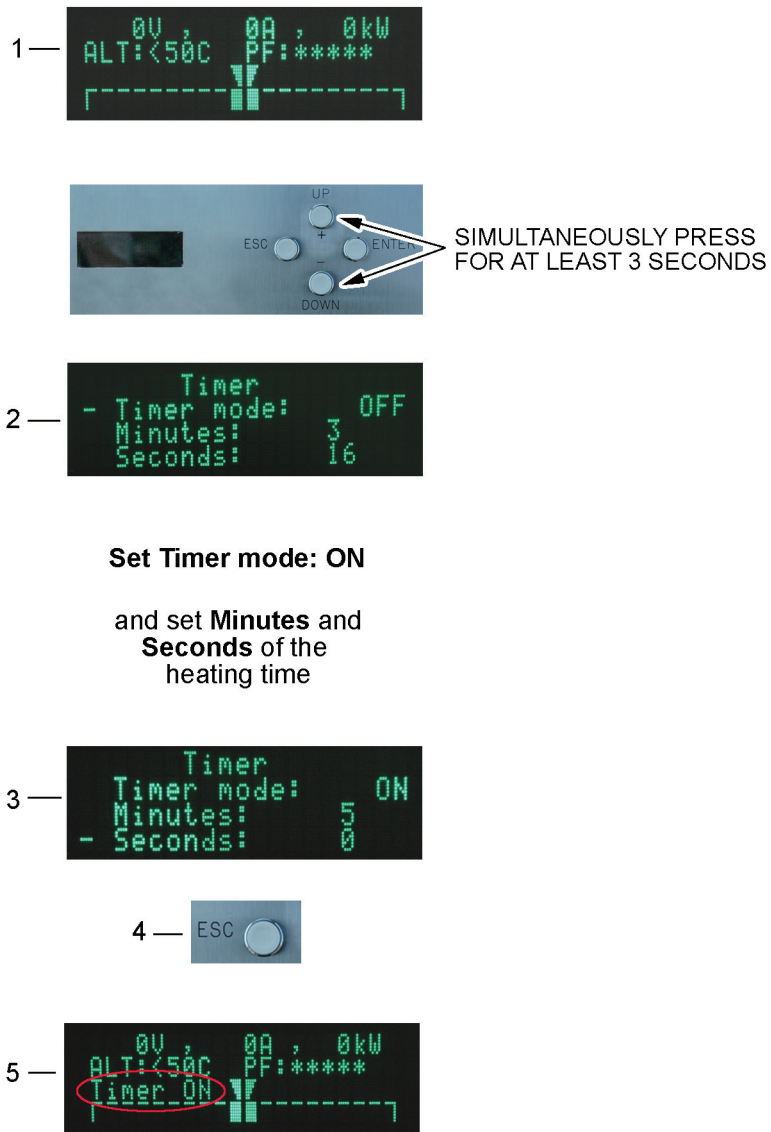

Figure 6.15 - Timer for setting the heating time

6.4.3.3 Setting of the pipe temperature (Optional)

The Induction Heating Generator IHG 120CU may be equipped with an automatic system that stops the heating cycle when the pipe reaches a preset temperature. In order to use this functionality it is necessary to connect to the temperature transducer socket connector (see Figure 6.16/1) a K thermocouple type temperature probe (see Figure 6.17/2). During the heating cycle the temperature probe shall be in contact with the section of the pipe (1) to be heated.

LEGEND

- 1 - Temperature transducer socket connector

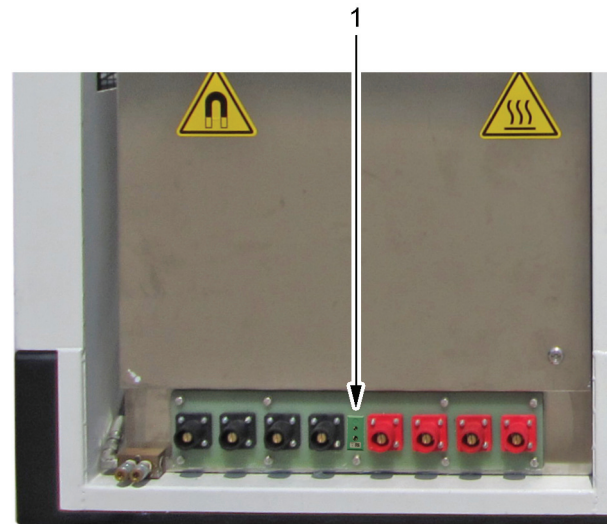

Figure 6.16 - Temperature transducer connector

LEGEND

- 1 - Pipe
- 2 - K thermocouple type temperature probe

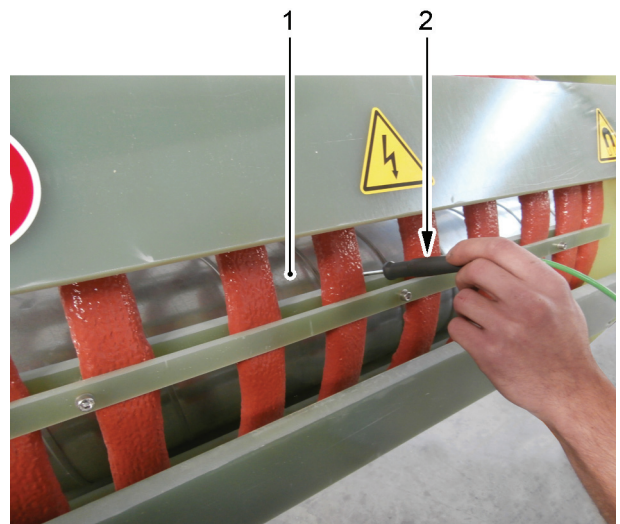

Figure 6.17 - K thermocouple type temperature probe

As far as actuation and setting of this function proceeds as indicated in the diagram of Figure 6.18.

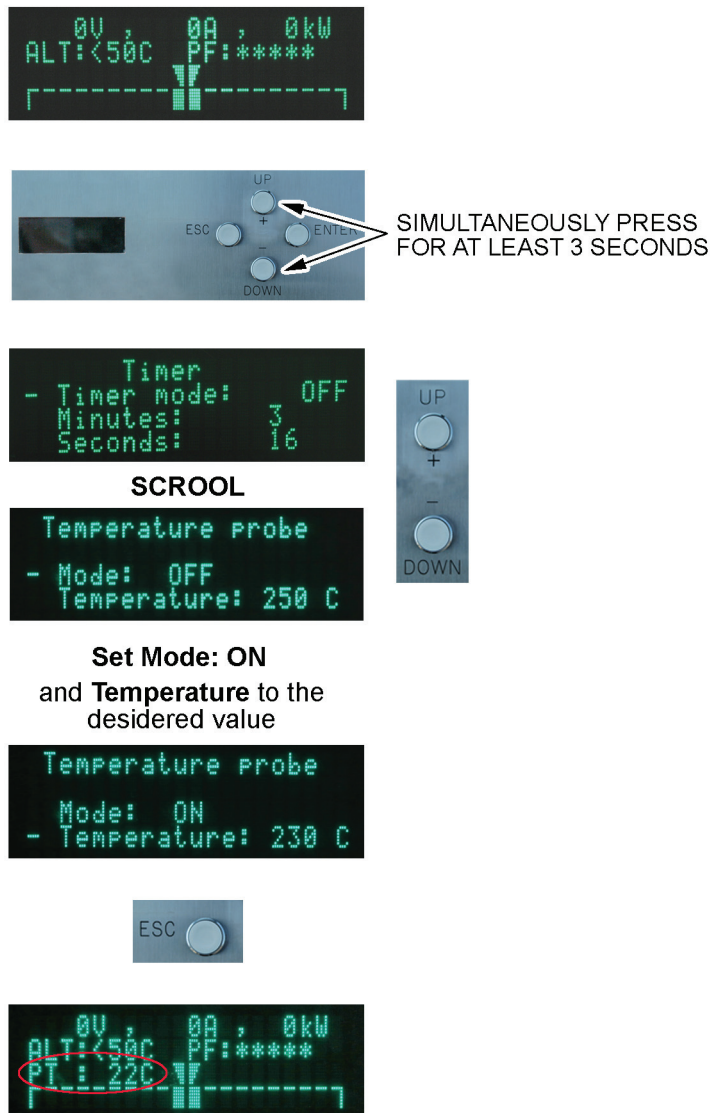

Figure 6.18 - Setting of the pipe temperature (Optional)



WARNING

In some generators the parameters may be protected by a password, then enter the user password each time it is requested.

- 1) From the operative mode page press the pushbuttons UP and DOWN for at least 3 seconds;
- 2) Press the UP or DOWN pushbutton in order to scroll the parameters until reaching the page "Temperature Probe";
- 3) Set "Mode" = ON and the temperature at which the heating cycle should stop. See paragraph 6.2.2.1c "Setting of the generator working and use parameters" for learning how to change the parameters.
- 4) Press ESC pushbutton for returning to the operative page. Now on the bottom left side there is the message "PT : xxC" which means that the heating cycle automatic stopping function, when the preset temperature is reached, is active and the current temperature of the pipe is xx°C.

6.4.3.4 Setting of the generator output power

Setting the power supplied by the generator (see Figure 6.19/2) means setting the current supplied by the alternator (1).

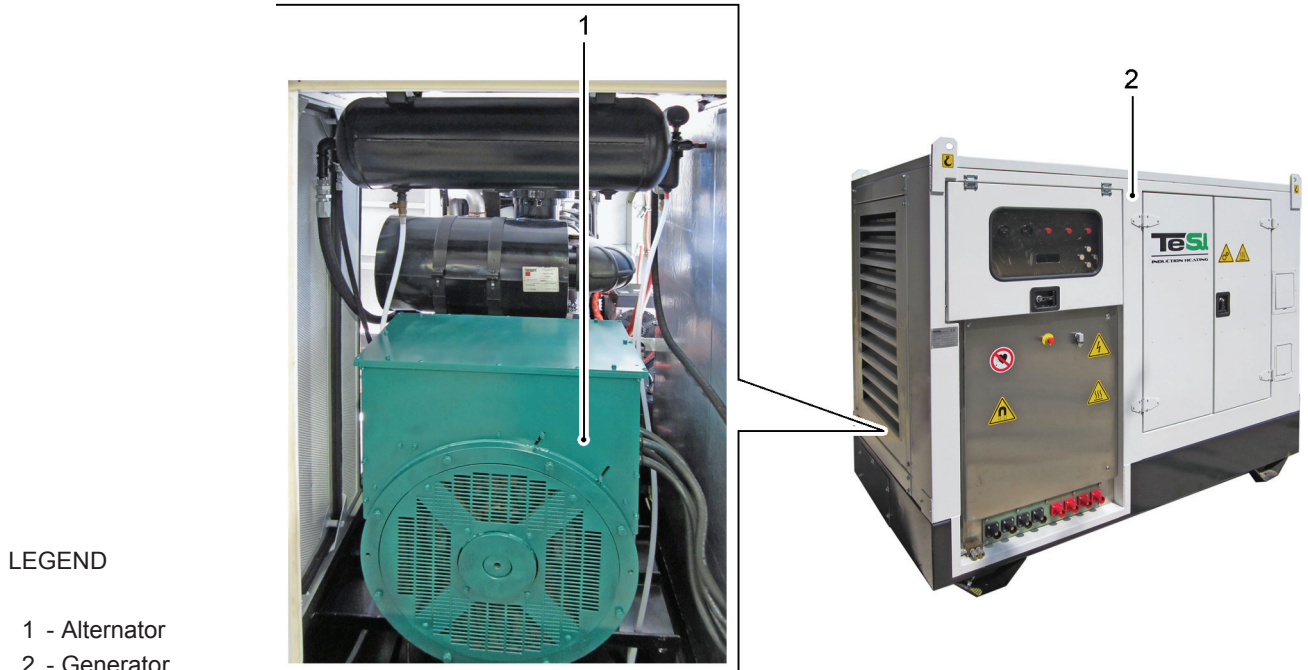

Figure 6.19 - Generator and alternator

The maximum settable value for the various types of coils is reported in the following Table 6.4.

Table 6.4 - Coils identification plate

COIL IDENTIFICATION PLATE	GENERATOR CURRENT SETTING
	<p>Set a current of 350 A max</p>

**NOTE**

As a general rule set the current approximately at a value half the value indicated on the coil plate (see figure in Table 6.4).

In order to set the heating power of the generator press, for at least 3 seconds, one of pushbuttons UP + (see Figure 6.20/3) or DOWN - (4) situated on the command and control panel (1) until entering the following page.



At this point press the pushbutton UP + (3) to increase the alternator output current (=generator output power) or pushbutton DOWN - (4) to decrease the alternator output current (=generator output power) until reaching the desired current value.

At the end of this operation the display (2) will remain on this page for a few seconds and then will return to the main page.

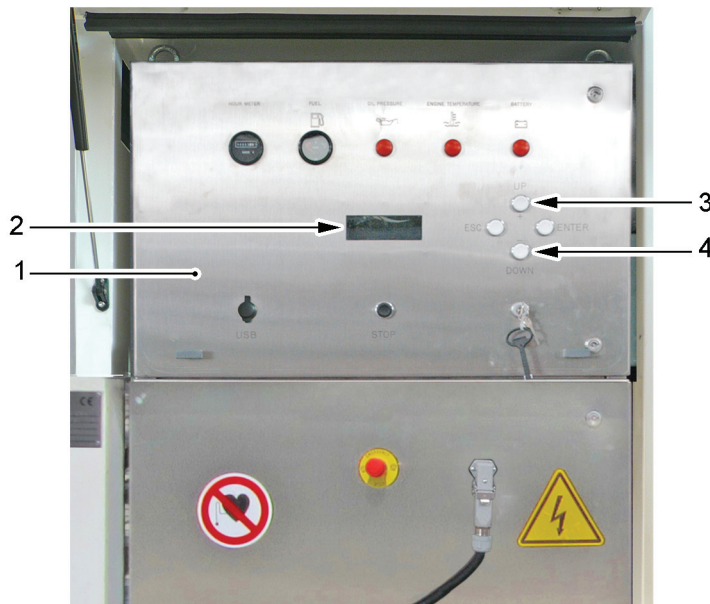

Figure 6.20 - Pushbuttons UP + and DOWN - for setting the generator output power

Higher is the power supplied by the generator higher is the heating rate of the generator pipe.

The heating power can be preset by setting the output current of the generator (settable values span from 200 A to 725 A).

During the heating cycle the generator controller tries to make the alternator supply the current set by the operator without exceeding the alternator maximum voltage, corresponding to 165 Volt. To this matter, it is important to know that the generator output voltage, besides depending on the current supplied by the alternator, even depends on many other factors, such as:

- number of coil turns;
- coil diameter;
- coil heating length;
- distance between coil winding and pipe;
- pipe material;
- etc..

therefore, **when the output voltage will reach the value of 165 V, the generator controller will limit the current to the purpose of not exceeding that value.**

Maybe because of the reached 165 V voltage that the alternator output current visualized on the display during the heating cycle do not correspond to the set value.

6.4.4 COILS' POSITIONING ON THE PIPE

According with the type of coil (standard clamp coil, heavy duty clamp coil, external ring coil or internal ring coil) to be used, proceed to position the selected coil on the pipe, by observing the modalities described in the following Paragraphs.

6.4.4.1 Standard clamp coil

	<p>NOTE The here following described operations must be carried out by two operators standing the one in front of the other, in the standard clamp coil opening sense.</p>
---	---

Carry out the here following reported operations:

	<p>PROHIBITION Never open the standard clamp coil when the Induction Heating Generator IHG 120CU is in the heating cycle phase.</p>
--	--

	<p>PROHIBITION For no reason carry out the disconnection of the power cables during the heating cycle.</p>
---	---

- 1) Loosen the knob (see Figure 6.21/2) releasing/locking the handle (1) for opening/closing the clamp coil (3).

	<p>WARNING By first opening, with the clamp coil hanging from the motor vehicle mechanical arm, a fast and uncontrolled opening of the coil itself will follow. Consequently, pay the utmost attention during the opening manoeuvre.</p>
---	---

- 2) Lower the handle (1) for opening/closing the clamp coil (3), in such a way to release the contacts for the (knife) turns' closing.
- 3) Carry on the lowering phase of the handle (1) for opening/closing the clamp coil (3), up to disengage the two hook levers (4) from the relevant pins (6).

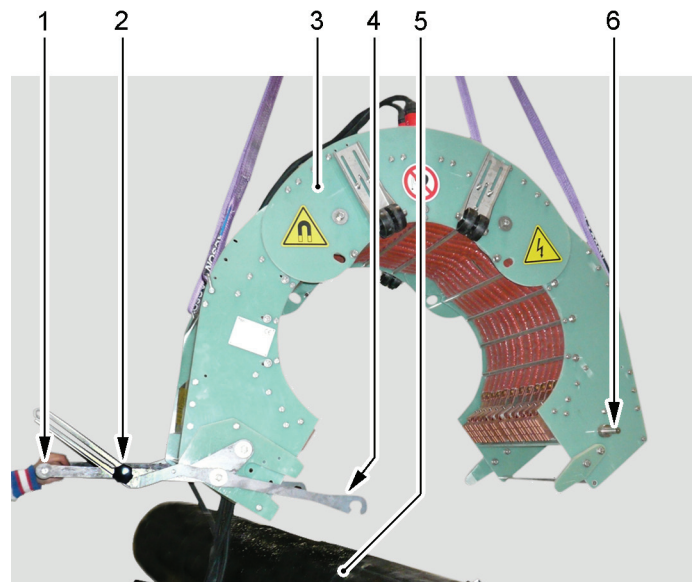

Figure 6.21 - Knob for releasing/locking the handle and release of the hook levers from the clamp coil pins

- 4) By using the motor vehicle mechanical arm, drop the clamp coil (see Figure 6.22/1) onto the pipe (2).

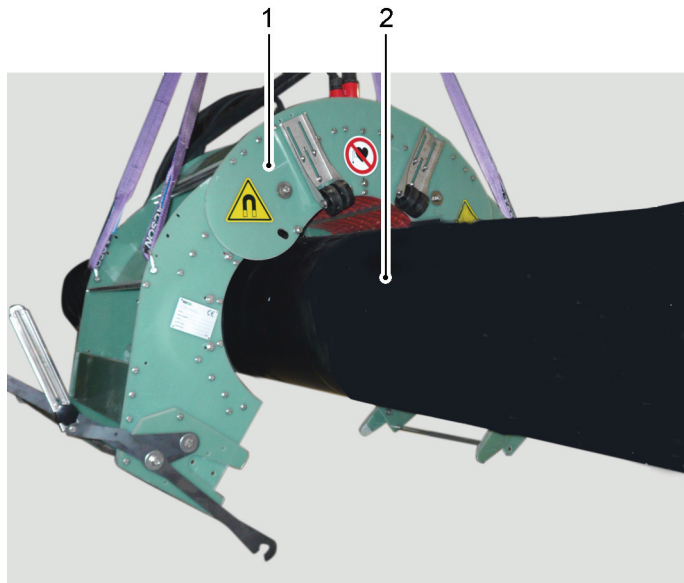

Figure 6.22 - Positioning of the clamp coil onto the pipe

- 5) By acting both from the handle side (see Figure 6.23/1) and from the opposite one, push the two shoulders of the clamp coil (2), until the contacts for the (knife) turns' closing get mutually coupled.



WARNING

During the clamp coil closing, make sure that the contacts for the (knife) turns' closing get mutually coupled in a correct way and without any jamming.

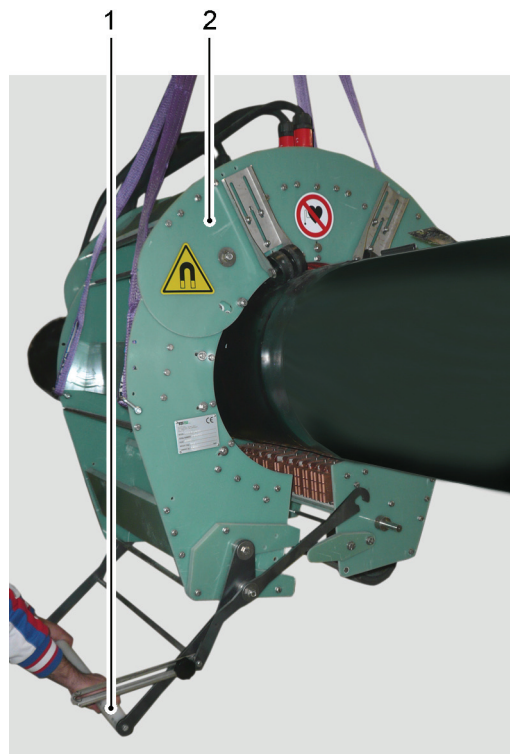

Figure 6.23 - Coupling of the contacts for the (knife) turns' closing

- 6) Get the two hook levers (see Figure 6.24/1) hooked to the pins (3), situated on the clamp coil (2).

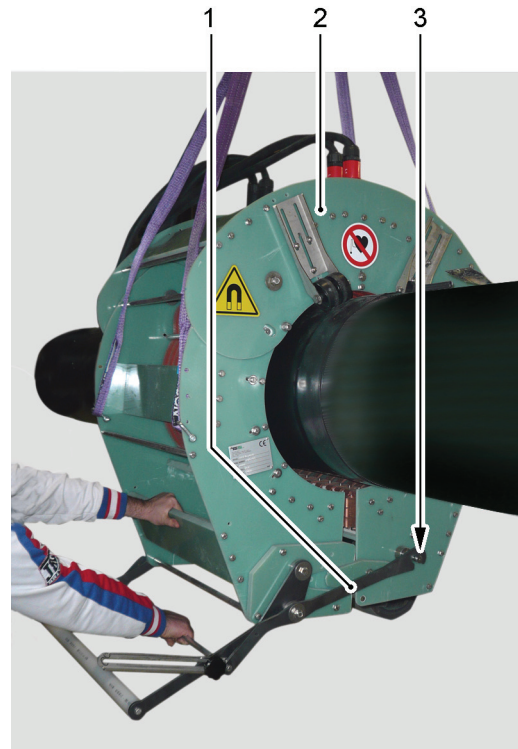

Figure 6.24 - Hooking of the hook levers to the pins

- 7) Fully lift the handle (see Figure 6.25/1) for opening/closing the clamp coil (2).

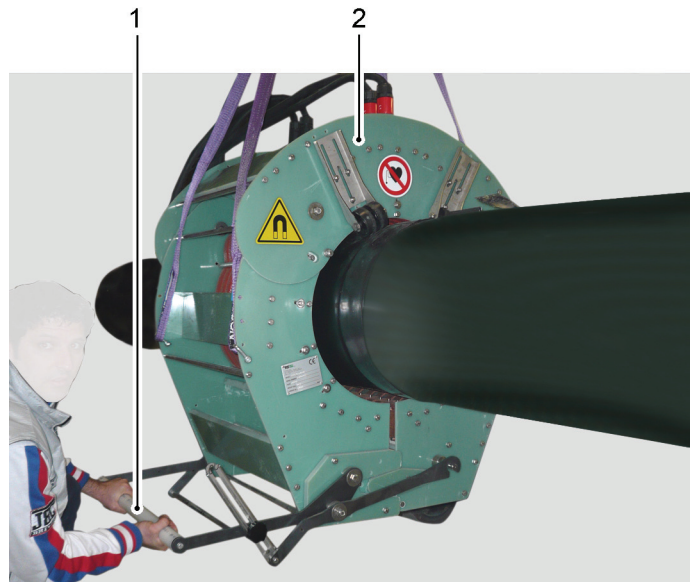

Figure 6.25 - Clamp coil closing

- 8) Lock the handle (see Figure 6.26/1) for opening/closing the clamp coil (3) by means of the knob (2).

**NOTE**

Carry out the next steps 9) and 10) only if the positioning being carried out is the first one.

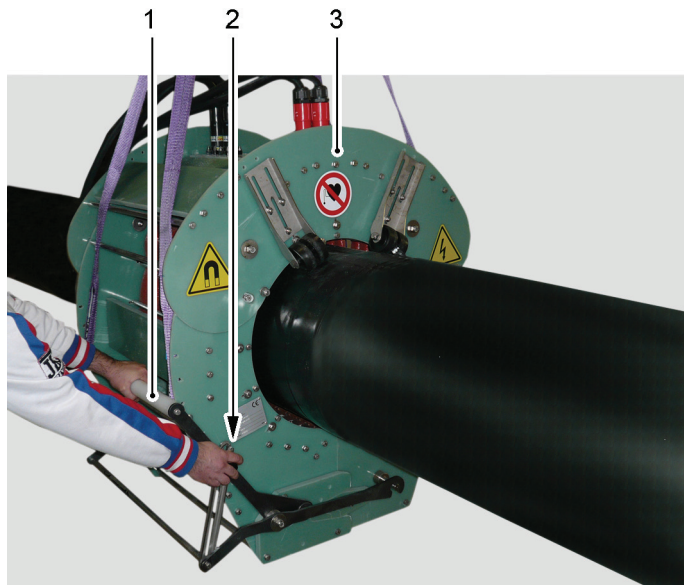

Figure 6.26 - Locking of the handle for opening/closing the clamp coil

- 9) Loosen the screws and the nuts (see Figure 6.27/3) fastening the adjustable supports (2) equipped with wheel (4), which allow to realize the centring of the clamp coil (1) on the pipe (5).
- 10) Get the clamp coil (1) centred on the pipe (5), by acting on the adjustable supports (2); then lock the adjustable supports (2) on position, by means of the screws and relevant nuts (3).
- 11) Remove the clamp coil from the pipe, by carrying out, in reverse order, the procedures described in the previous steps 3) ÷ 1).
- 12) By using the motor vehicle mechanical arm, lift the clamp coil from the pipe.

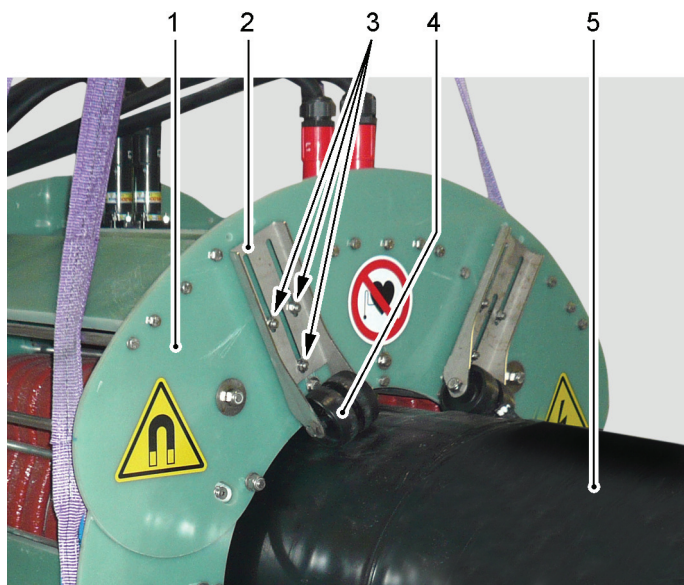

Figure 6.27 - Centring of the clamp coil on the pipe

6.4.4.2 Heavy duty clamp coil

**NOTE**

The here following described operations must be carried out by one operator.

Carry out the here following reported operations:

	<p>PROHIBITION Never open the heavy duty clamp coil when the Induction Heating Generator IHG 120CU is in the heating cycle phase.</p>
---	--

	<p>PROHIBITION For no reason carry out the disconnection of the power cables during the heating cycle.</p>
---	---

a) First opening

	<p>CAUTION The first opening of the heavy duty clamp coil, while lifted with a crane, it could be dangerous due to fast and uncontrolled movement of the clamp coil shoulders. To prevent any injuries or damages please follow the instruction below.</p>
---	---

- 1) A rope (see Figure 6.28/2) should be tied up at an handle bar (1) on one side and then wrapped around the handle bar (1) on the other side. It is suggested, in order to reduce the force needed, to wrap the rope (2) around the two bars at least twice.

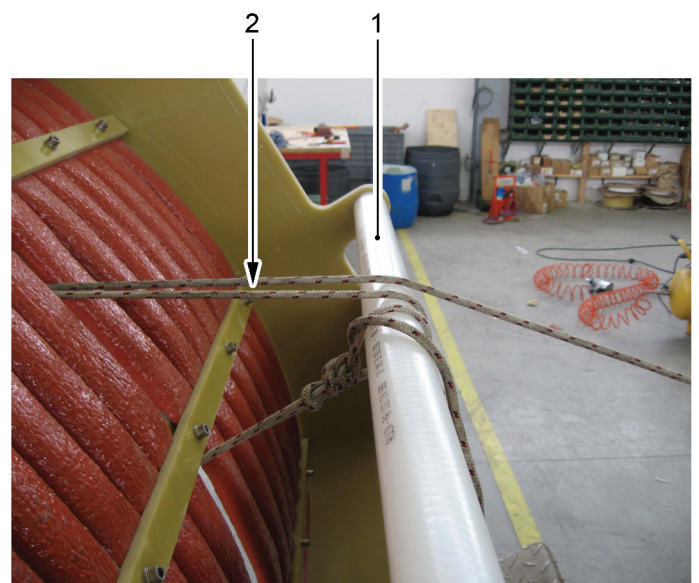
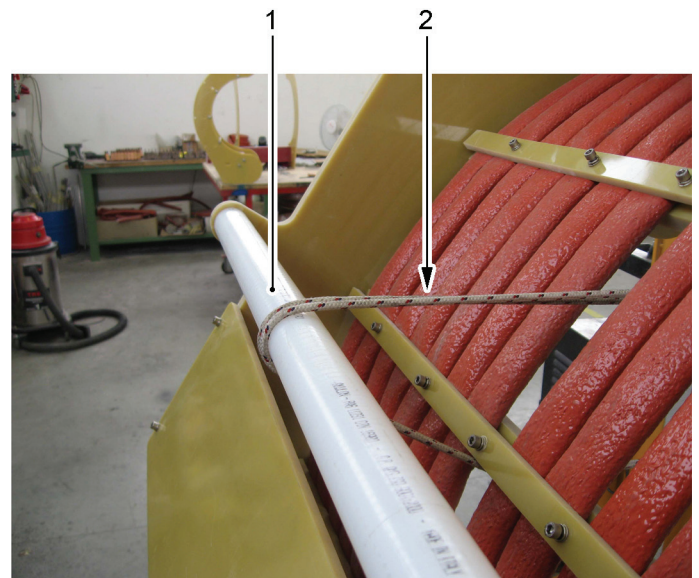

Figure 6.28 - Fastening of the rope to the handle bars

- 2) Hold the rope and press the OPEN pedal (see Figure 6.29) till the end of its stroke.



Figure 6.29 - Opening of the clamp coil through the OPEN pedal

- 3) The closure mechanism is now open and by gently releasing the rope proceed till a complete opening of the clamp coil (see Figure 6.30/1).
- 4) Remove the rope and move the clamp coil (1) onto the pipe.



Figure 6.30 - Complete opening of the clamp coil

b) Closing procedure

- 5) Before to move the clamp coil (see Figure 6.31/2) onto the pipe (1), the four wheels (3) have to be adjusted trying to have the clamp coil (2) centred, so with an even gap between pipe (1) and clamp coil (2) shoulders. This gap, so the wheels (3) position, can be then better adjusted once the clamp coil (2) is on the pipe (1) still lifted with the crane.

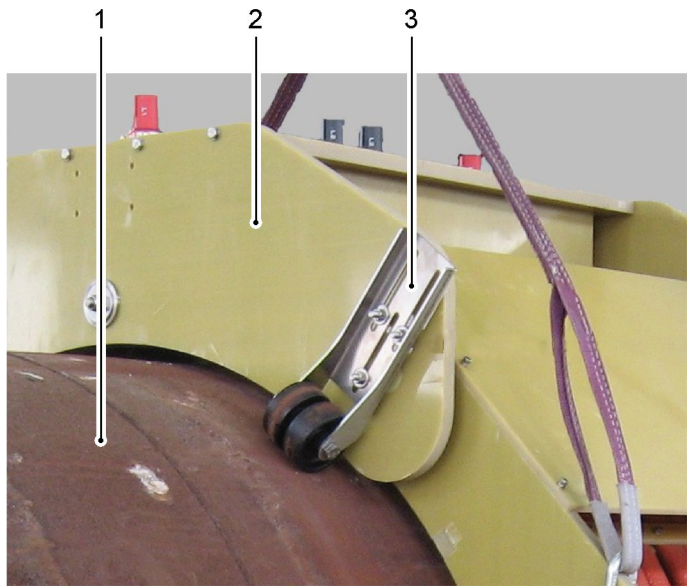

Figure 6.31 - Centring of the clamp coil on the pipe

- 6) Move down the clamp coil (see Figure 6.32/2) onto the pipe (1).

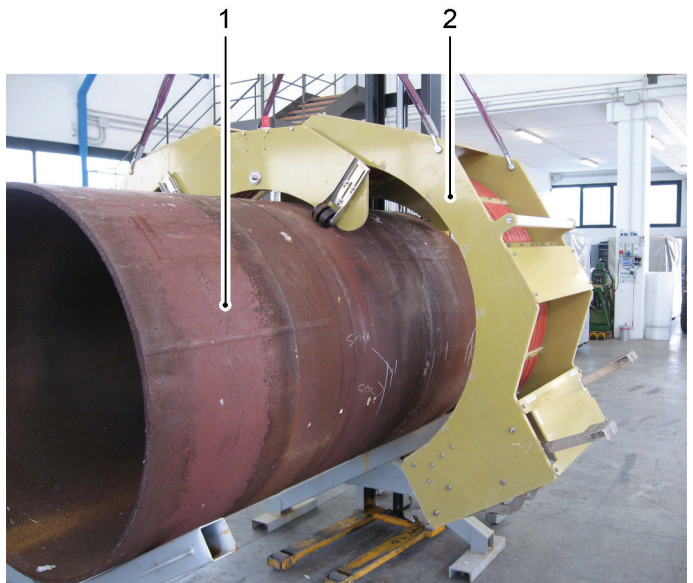

Figure 6.32 - Moving down of the clamp coil onto the pipe

- 7) Proceed by moving the clamp coil (see Figure 6.33/1) down till it'll be closed.

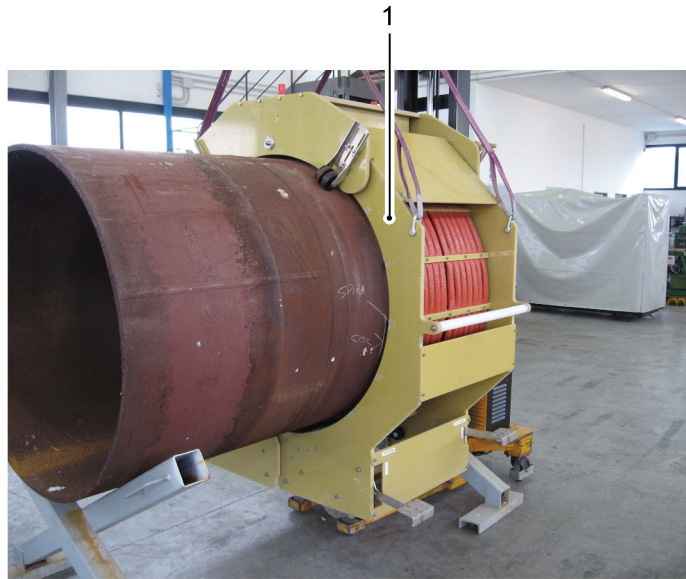

Figure 6.33 - Closing of the clamp coil for its moving down onto the pipe

- 8) The closing mechanism should automatically hook the opposite side of the clamp coil (see Figure 6.34/1). Looking at the bottom of the clamp coil (1) check, on both sides, that the two hooking arms (3) catch the bar (2) on the opposite shoulder.

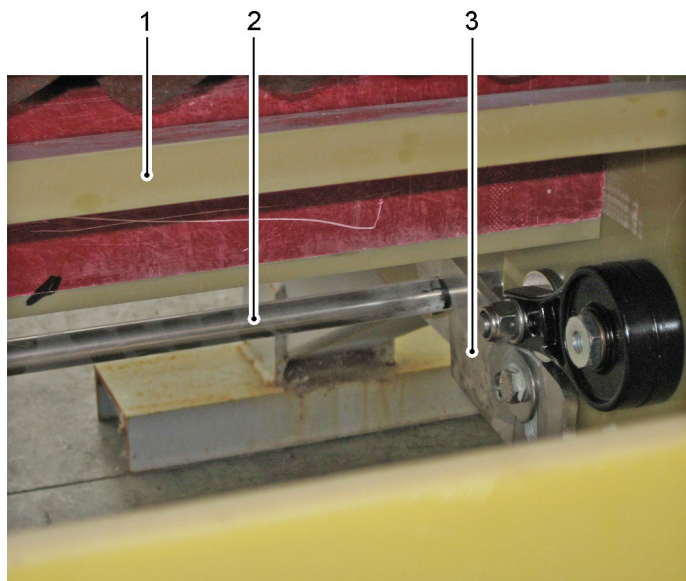

Figure 6.34 - Automatic closing of the clamp coil

- 9) To completely close the clamp coil (see Figure 6.35/1) proceed now pressing the CLOSE pedal. Hold the hand bar and press with adequate force the pedal till the end of its stroke.



Figure 6.35 - Complete closing of the clamp coil through the CLOSE pedal

- 10) In case the hooking arms (see Figure 6.36/3) remain lifted, it could happen in case you partially open the clamp coil (1) and then try to close it, pull the handle bar (2) on the clamp coil (1) shoulder a bit trying to open it. The same result is obtained by lifting a bit the clamp coil (1) with the crane.

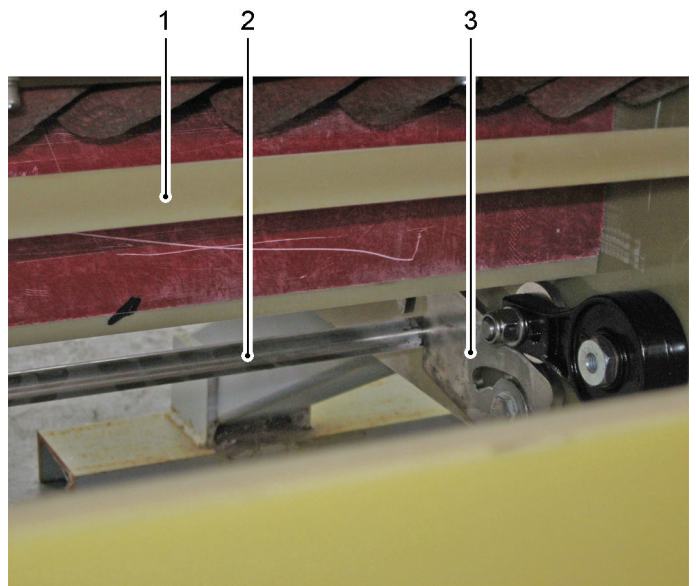

Figure 6.36 - Partial opening of the clamp coil by hooking arms kept lifted

c) Opening procedure

- 11) To open the clamp coil (see Figure 6.37/1), hold the handle bar and press the OPEN pedal till the end of its stroke.



Figure 6.37 - Opening of the clamp coil through the OPEN pedal

- 12) The two hooking arms (see Figure 6.38/2) will release the bar (1) on the opposite shoulder.

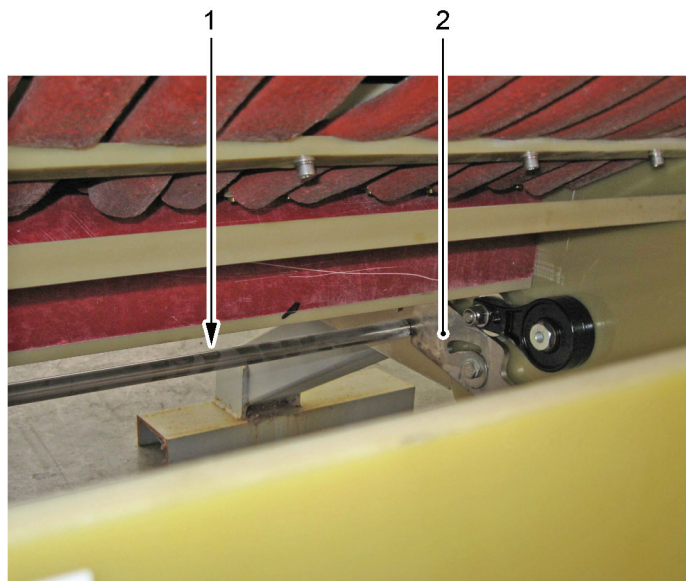

Figure 6.38 - Release of the bar on the opposite shoulder

- 13) Keeping the pedal pressed at the end of its stroke, start to lift the clamp coil (see Figure 6.39/1) by the crane. The pedal can be released once the clamp coil (1) is opened for a few centimetres.
- 14) Proceed now lifting the clamp coil (1) till a complete opening.



Figure 6.39 - Use of the OPEN pedal for the clamp coil complete opening

6.4.4.3 Pair of external ring coils

Carry out the here following indicated operations:

	<p>PROHIBITION Never remove the external ring coil when the Induction Heating Generator IHG 120CU is in the heating cycle phase.</p>
--	---

	<p>PROHIBITION For no reason carry out the disconnection of the power cables during the heating cycle.</p>
--	---

- 1) By using the motor vehicle mechanical arm, lower the external ring coils (see Figure 6.40/2) in correspondence with the pipe (1) to be treated.
- 2) Fit the external ring coils (2) onto the pipe (1), up to stop.
- 3) Remove the external ring coils, by carrying out, in reverse order, the procedures described in the previous steps 2) and 1).

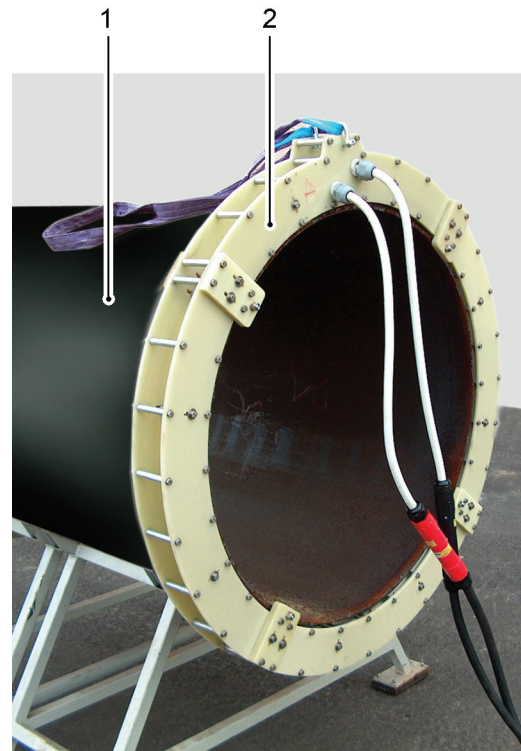

Figure 6.40 - Positioning of the external ring coils onto the pipe

6.4.4.4 Pair of internal ring coils

Carry out the here following indicated operations:

**PROHIBITION**

Never remove the internal ring coil when the Induction Heating Generator IHG 120CU is in the heating cycle phase.

**PROHIBITION**

For no reason carry out the disconnection of the power cables during the heating cycle.

- 1) By using the motor vehicle mechanical arm, lower the internal ring coils (see Figure 6.41/1) in correspondence with the pipe (2) to be treated.
- 2) Fit the internal ring coils (1) onto the pipe (2), up to stop.
- 3) Remove the internal ring coils, by carrying out, in reverse order, the procedures described in the previous steps 2) and 1).

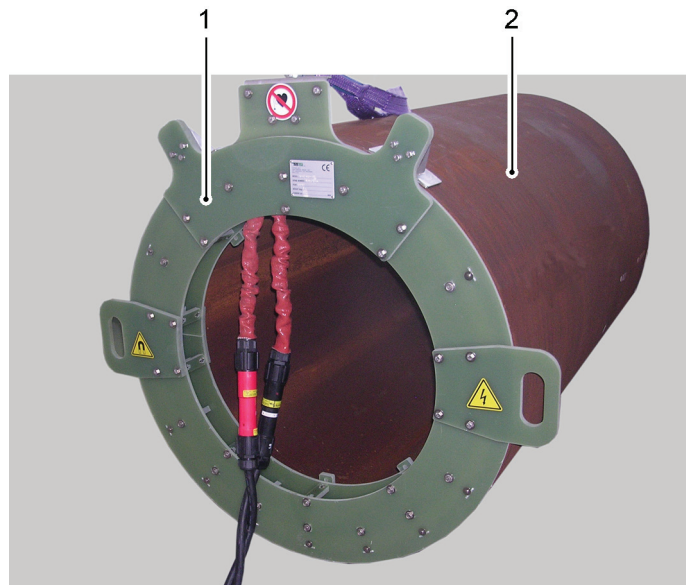



Figure 6.41 - Positioning of the internal ring coils onto the pipe

6.4.5 POWER FACTOR CORRECTION

6.4.5.1 Operating mode set on “auto” (default parameter)

“PF Correction” parameter set on “AUTO”



	<p>NOTE</p> <p>The generator automatically keeps the Power Factor (PF) as near as possible to 1.0 in presence of variable operating conditions (dimensions of the pipe to be heated and generator output power).</p> <p>This automatic system provides to control the PF at every heating cycle and, if necessary, in the subsequent heating cycles it will change the number of capacitors to the purpose of optimizing the PF.</p> <p>Each time the generator load varies, i.e. the type of tube to be heated is changed, it is advisable to perform some preliminary heating cycles in such a way to let the generator adjust the Power Factor (PF) as near as possible to 1.0.</p>
---	---

	<p>CAUTION</p> <p>It is very important to keep the Power Factor (PF) as near as possible to 1.0, in order to improve the generator efficiency and avoid overheating the power cables, connecting the coil to the generator.</p>
---	--

After having carried out the setting operations described in Paragraphs 6.4.1, 6.4.2 and 6.4.3, perform some heating cycles.

6.4.5.2 Operating mode set on “man”

“PF Correction” parameter set on “MANUAL”



	<p>NOTE</p> <p>It is possible to manually correct the power factor of the Induction Heating Generators IHG 120CU by setting to “MAN” the operating mode of the “PF Correction” parameter (see Table 6.2).</p>
---	--

After having carried out the setting operations described in Paragraphs 6.4.1, 6.4.2 and 6.4.3, proceed as here following indicated:

- press the heating cycle start "START" pushbutton (see Figure 6.42/6), situated on the remote control (7). The lighting up of the green light (5) on the remote control (7) confirms that the heating cycle start took place. When the engine reaches the maximum speed the display shows the PF value.



This value can become:

- **Capacitive** (postfix letter associated to the value "C");
- **Inductive** (postfix letter associated to the value "I").
- stop the heating cycle in progress, by pressing either of the two heating cycle stop "STOP" pushbuttons (see Figure 6.42/3 or 4), situated on the command and control panel (1) and on the remote control (7).



CAUTION

It is very important to keep the Power Factor (PF) as near as possible to 1.0, in order to improve the generator efficiency and avoid overheating the power cables, connecting the coil to the generator.

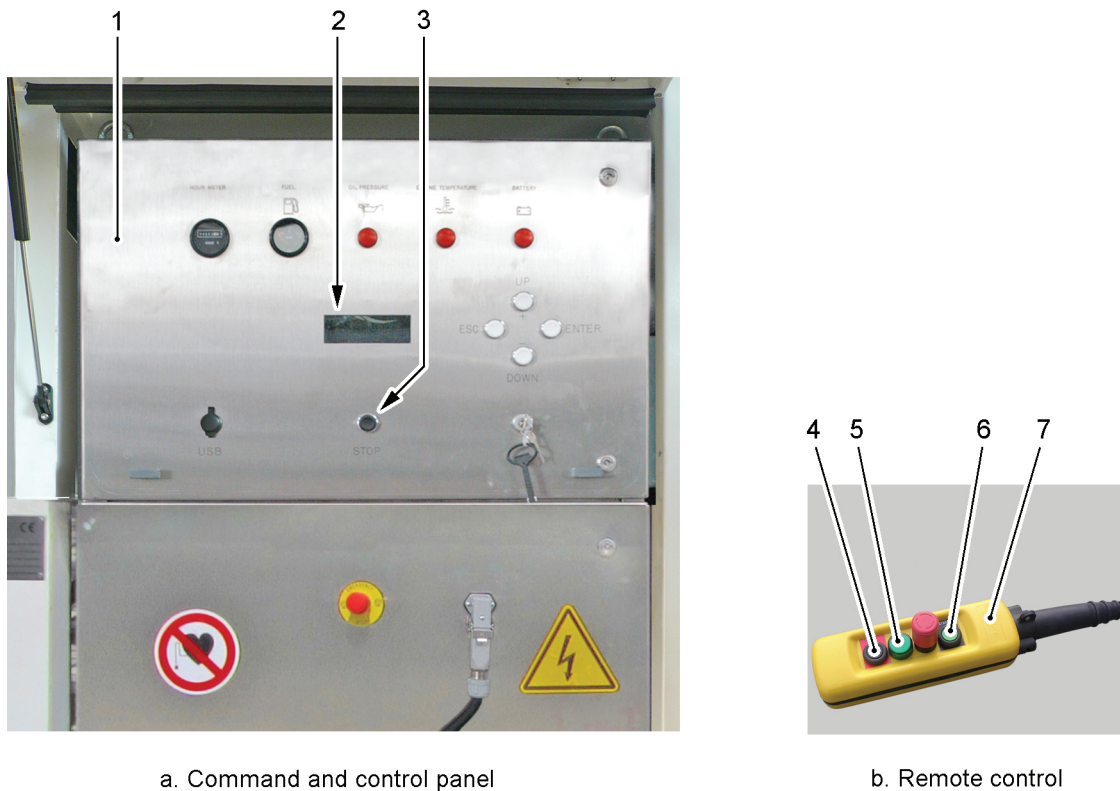

a. Command and control panel

b. Remote control

Figure 6.42 - Command and control

Now, in order to reach the system maximum efficiency, bring the Power Factor (PF) to 1.0 (or as near as possible to that value), by executing:

- a coarse regulation;
- a fine regulation.

a) Coarse regulation

The coarse regulation is realized by modifying the value of the “Cap. Switch N. Man.” parameter:

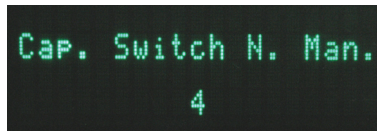

- if to the power factor (PF), visualized on the display (see Figure 6.42/2) of the command and control panel (1), the letter “C” is associated, it will be necessary to reduce the number of the capacitor banks, by intervening on the “Cap. Switch N. Man.” parameter (see Paragraph 6.2.2.1c). If, on the contrary, the letter “I” results to be associated to the power factor (PF), the number of the capacitor banks shall be increased.

b) Fine regulation

The fine regulation is realized by modifying the value of the “Half Cap. Switch Man.” parameter:

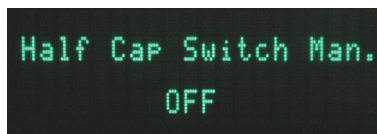

- if to the power factor (PF), visualized on the display (see Figure 6.42/2) of the command and control panel (1), the letter “C” is associated, it will be necessary to switch OFF the half capacitor bank by intervening on the “Cap. Switch N. Man.” parameter (see Paragraph 6.2.2.1c). If, on the contrary, the letter “I” results to be associated to the power factor (PF), it will be necessary to switch ON the half capacitor bank.
- stop the heating cycle in progress, by pressing either of the two heating cycle stop “STOP” pushbuttons (3 or 4), situated on the command and control panel (1) and on the remote control (7).

6.4.6 OPERATION

6.4.6.1 General

After having completed the operations reported in the previous Paragraphs 6.4.3, 6.4.4, and 6.4.5, proceed to use the Induction Heating Generator IHG 120CU, by carrying out the requested heating cycles.

According with some given requirements, such as environmental conditions, use area, etc., the operator can choose to control the heating cycles either in manual or in automatic mode.

	<p>PROHIBITION Never open or remove the coils when the Induction Heating Generator IHG 120CU is in the heating cycle phase.</p>
--	--

	<p>PROHIBITION For no reason carry out the disconnection of the power cables during the heating cycle.</p>
--	---

6.4.6.2 Manual mode

For the Induction Heating Generator IHG 120CU operation in manual mode it will be necessary to proceed as here following described:

- 1) Set Timer mode = OFF and Temperature probe = OFF (see Paragraph 6.4.3.2).
- 2) Press the heating cycle start “START” pushbutton (see Figure 6.43/4), situated on the remote control (5). The heating in progress “START” warning light (2) lights up, in order to confirm that the heating cycle has been started.

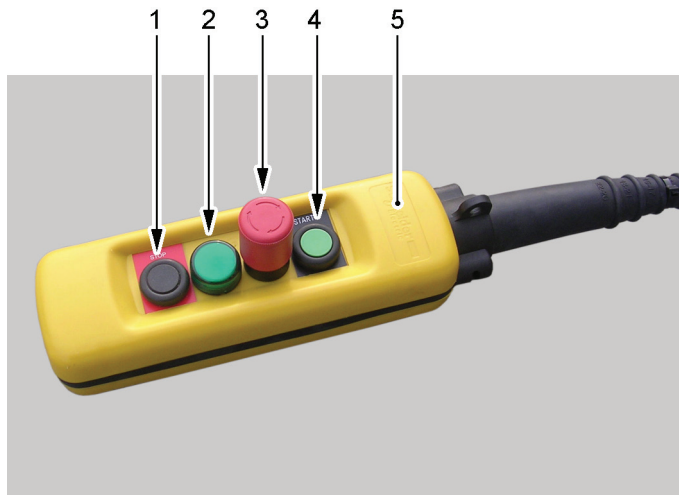

Figure 6.43 - Remote control

- 3) When the requested heating temperature was been reached, press the heating cycle stop “STOP” pushbutton (1).
- 4) If requested, start up again the heating cycle, by carrying out, in sequence, the steps from 2) to 3).

6.4.6.3 Automatic mode with timer

For the Induction Heating Generator IHG 120CU operation in automatic mode it will be necessary to proceed as here following described:

- 1) Set Timer mode = ON and set the heating time (see Paragraph 6.4.3.2).
- 2) Press the heating cycle start “START” pushbutton (see Figure 6.43/4), situated on the remote control (5). The heating in progress “START” warning light (2) lights up, in order to confirm that the heating cycle has been started.
- 3) The heating cycle automatically stops, as soon as the set heating time is reached (see Paragraph 6.4.3.2).
- 4) If requested, start up again the heating cycle, by carrying out, in sequence, the steps from 2) to 3).

6.4.6.4 Automatic mode with temperature probe (Optional)

For the Induction Heating Generator IHG 120CU operation in automatic mode it will be necessary to proceed as here following described:

- 1) Set Temperature probe mode = ON and set the temperature (see Paragraph 6.4.3.3);
- 2) Press the heating cycle start “START” pushbutton (see Figure 6.43/4), situated on the remote control (5). The heating in progress “START” warning light (2) lights up, in order to confirm that the heating cycle has been started.

- 3) The heating cycle automatically stops, as soon as the set temperature is reached (see Paragraph 6.4.3.3).
- 4) If requested, start up again the heating cycle, by carrying out, in sequence, the steps from 2) to 3).

	<p>WARNING Both the pipe and the coil are hot after the heating cycles. Therefore, pay a particular attention during the coil removal phase, and strictly observe the instructions reported in Chapter 3 “Safety Rules”.</p>
---	---

	<p>WARNING Should any particularly dangerous conditions take place during the heating cycles, press the mush-room-head emergency pushbutton (3).</p>
---	---

	<p>NOTE Absolutely avoid resetting the red mush-room-head pushbutton before the engine has completely stopped.</p>
---	---

	<p>CAUTION In order to avoid engine and alternator overheating, after any heating cycle never turn off the engine immediately, but leave the Induction Heating Generator IHG 120CU running idle for at least 10 minutes.</p>
---	---

	<p>NOTE During normal operation, no particular checks are required for keeping the Induction Heating Generator IHG 120CU in perfect efficiency, exception made for those indicated in Paragraph 6.4.7 and at refuelling.</p>
--	---

6.4.7 CHECKS TO BE CARRIED OUT DURING OPERATION

During operation, the operator must perform certain checks, since, in addition to normal maintenance operations, alarm or emergency conditions may arise.

For this reason, the operator must regularly check the command and control panel, on which the display and the warning lights are situated, both as far as the operating cycle and the relevant temperature, current, etc. values are concerned, and perform the checks relevant to the engine conditions.

In case of an emergency or alarm situation, it will be necessary to immediately stop the Induction Heating Generator IHG 120CU and to identify the type of fault which occurred.

	<p>CAUTION In case of doubts about the type of intervention to be undertaken in order to restore the correct operation of the Induction Heating Generator IHG 120CU, it is suggested to contact the TeSi s.r.l. “After-Sales Technical Service”, since inappropriate action could cause further damages to the generator itself.</p>
---	---

As far as the emergency or alarm indications, which can be directly checked on the command and control panel, are concerned, reference shall be made to the information reported in Chapter 8 “Diagnostics”, which also contains the list of the failures which could arise during the normal operation of the Induction Heating Generator IHG 120CU.

	<p>NOTE For information concerning the possible failures to the engine, reference shall be made to the relevant “Owners Manual - QSB4.5 and 6.7”, delivered by TeSi s.r.l. as a Joined Publication to this manual.</p>
---	---

6.5 COMPRESSED AIR SYSTEM (OPTIONAL)

On the Induction Heating Generator IHG 120CU a system for generating compressed air may be installed as optional (see Paragraph 2.2.5). The compressed air couplings (see Figure 6.44/3) are situated in the vicinity of the power connectors (2).



NOTE

The flow rate of 17 CFM for the compressor can be achieved only and exclusively with the engine in "CRUISE" speed (1).



LEGEND

- 1 - Engine speed selector "IDLE/CRUISE"
- 2 - Power connectors
- 3 - Compressed air couplings

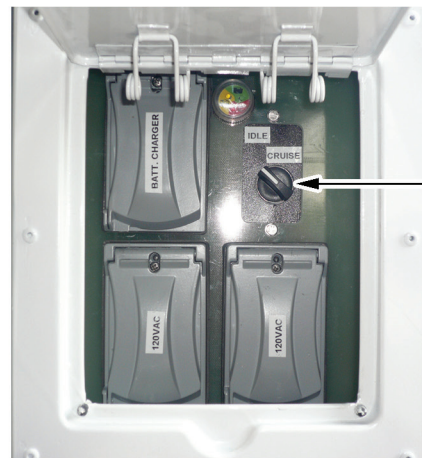
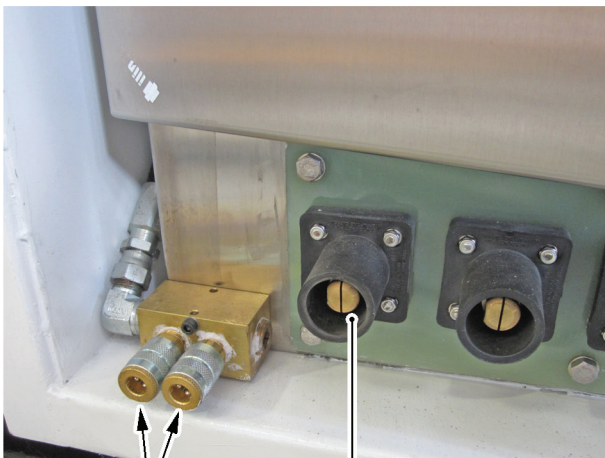

Figure 6.44 - Compressed air system (Optional)

6.6 120 VAC AUXILIARY GENERATOR (OPTIONAL)

On the Induction Heating Generator IHG 120CU a 120 Vac electric power generator may be installed as optional (see Paragraph 2.2.6). On the generator front part the 120 Vac electric sockets (see Figure 6.45/2) are installed.



WARNING

Use the 120 Vac electric sockets (2) exclusively when the engine is operating at its maximum speed (CRUISE speed).



WARNING

Act on the engine speed selector “IDLE/CRUISE” (1) in order to bring the engine to the “CRUISE” speed.

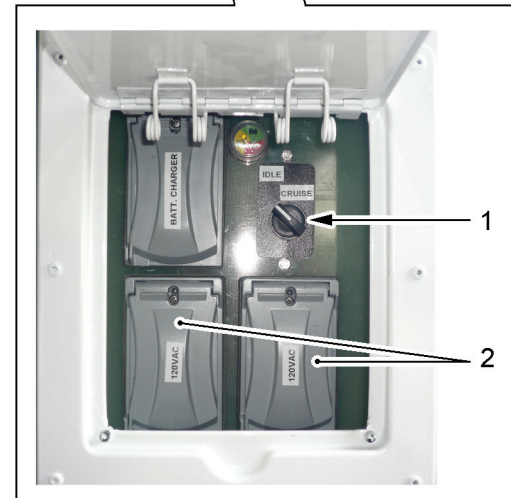

LEGEND

- 1 - Engine speed selector “IDLE/CRUISE”
- 2 - 120 Vac electric sockets

Figure 6.45 - 120 Vac auxiliary generator (Optional)

6.7 BATTERY CHARGER (OPTIONAL)

On the Induction Heating Generator IHG 120CU a battery charger (see Figure 6.46) may be installed as optional. The activation of the battery charger can be effected by simply connecting a 120 Vac socket to the electric plug (1) located inside the cover (2).

On the battery charger is also present an indicator (3) of the batteries charge state.



WARNING

Do not power the command and control panel of the generator when the battery charger (see Figure 6.46) is operating.



LEGEND

- 1 - Electric plug
- 2 - Cover
- 3 - Batteries charge state indicator

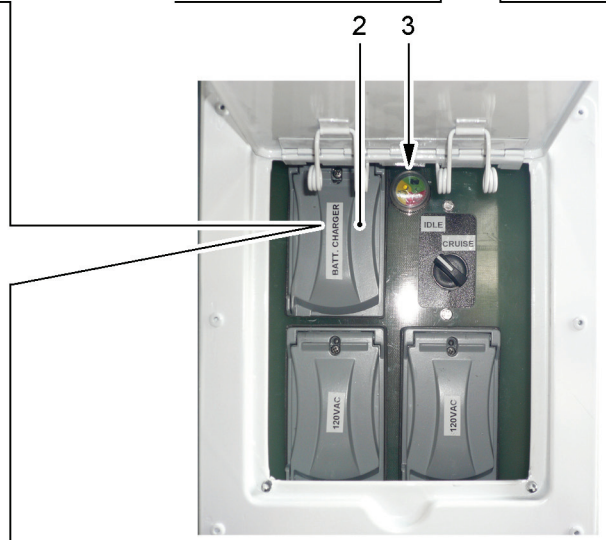

Figure 6.46 - Battery charger (Optional)

6.8 LOGGER (OPTIONAL)

On the Induction Heating Generator IHG 120CU a software may be installed that records the heating cycle main data, alarms and events related to the generator main working parameters preset changes.

The storing capacity is 1000 heating cycles approximately, from which it is determined that, considering a working cycle of 150 heating cycles a day, the memory shall be fully occupied every 7 days. When the memory is full the older data shall be overwritten. Then, to the purpose of not losing any data, it is advisable to download them via USB at least once a week.

In order to accede to the “logger” menu the generator must be in “Idle mode”; at this point go to the page “SHOW LOGGER” (see Paragraph 6.2.2.1) and follow the indications reported in the flow diagram illustrated in Figure 6.47.

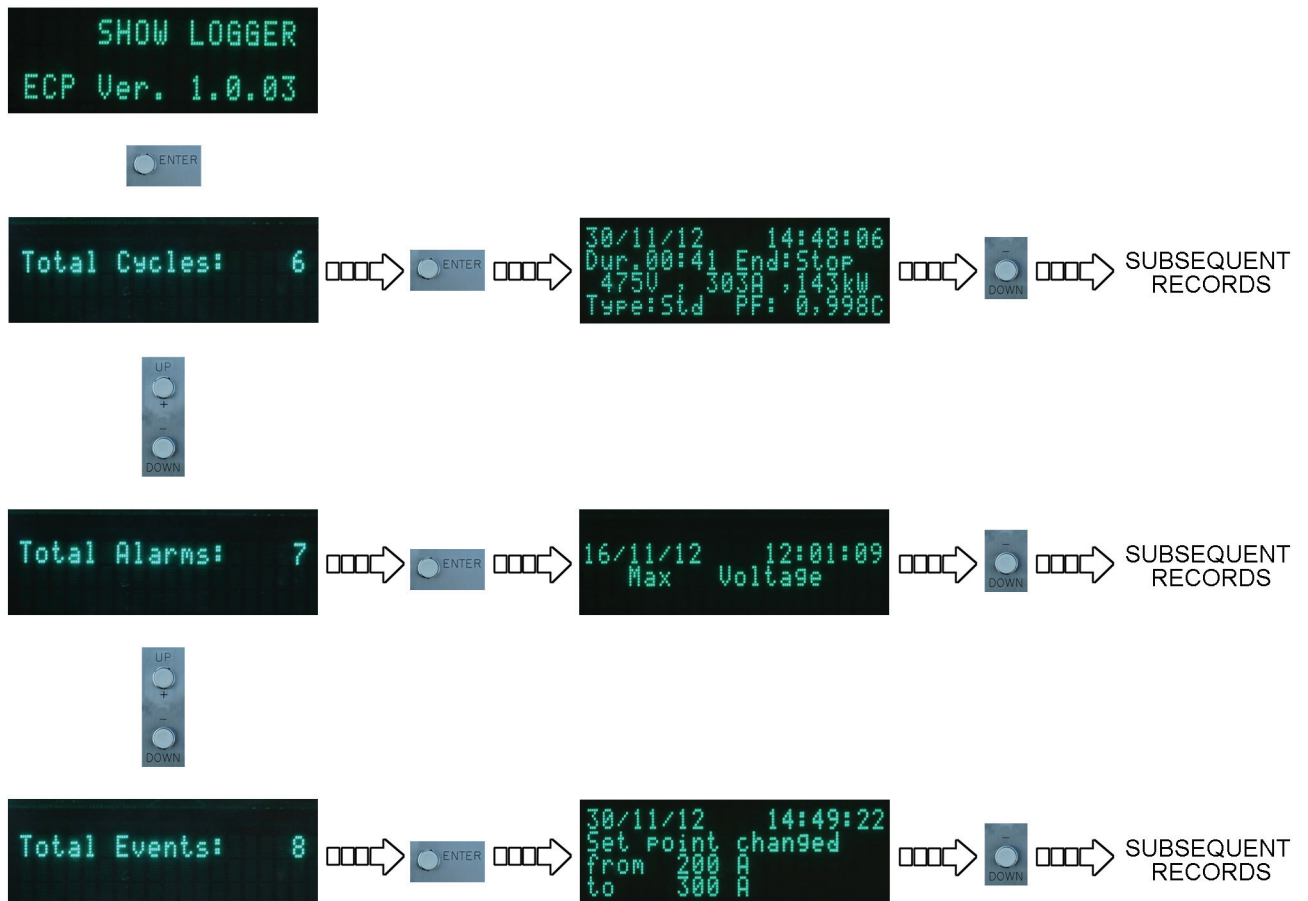

Figure 6.47 - Setting menu of the LOGGER (Optional) (flow diagram)

6.8.1 HEATING CYCLES LOGGER

In order to visualize the heating cycle records follow the indications reported in the flow diagram illustrated in Figure 6.47.

The meaning of each field of the heating cycle page is reported here-to-follow (see Figure 6.48).

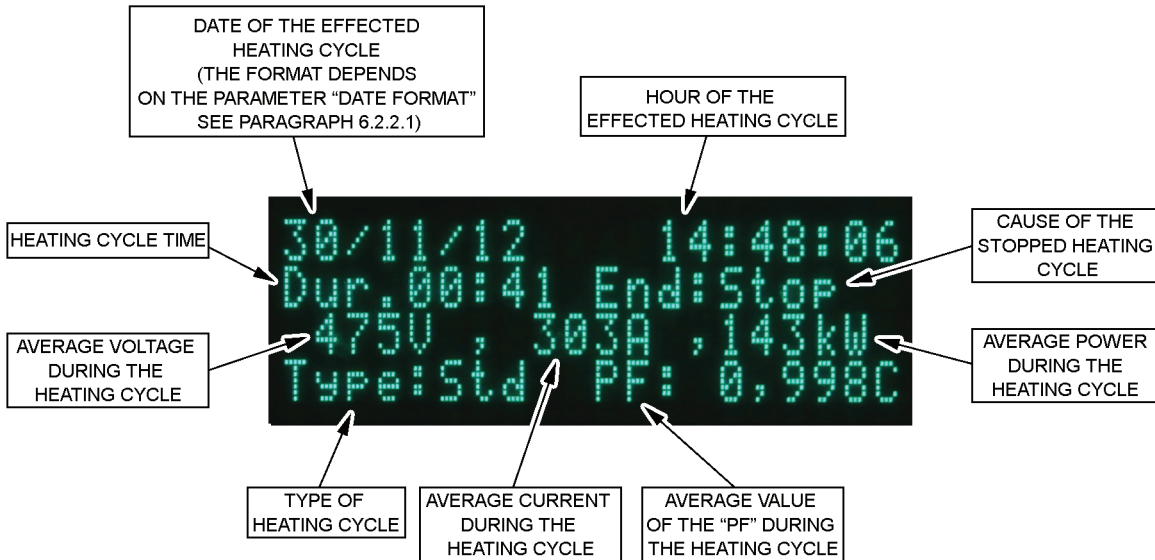

Figure 6.48 - Visualization of the heating cycle records

END: cause of the heating cycle stopping. Among the causes may be:

- Stop = the “STOP” pushbutton has been pressed;
- Alarm = the cycle has stopped because of an alarm;
- Timer = the cycle has automatically stopped because the timer preset time has expired;
- Temp = the cycle has automatically stopped when the pipe has reached the temperature set in the parameter “Temperature probe” (see Paragraph 6.4.3.3),
- Compl. = during a heating cycle for correction of the “PF”, the cycle itself has automatically stopped once the best “PF” value has been reached.

TYPE: the heating cycles are so classified:

- Std = standard heating cycle;
- AutoPF = heating cycle activated for optimizing the “PF” value.

6.8.2 ALARMS LOGGER

In order to visualize the alarm records follow the indications reported in the flow diagram illustrated in Figure 6.47.

The meaning of each field of the alarm page is reported here-to-follow (see Figure 6.49).

As far as the list and meaning of the alarms is concerned refer to Paragraph 8.1.1.

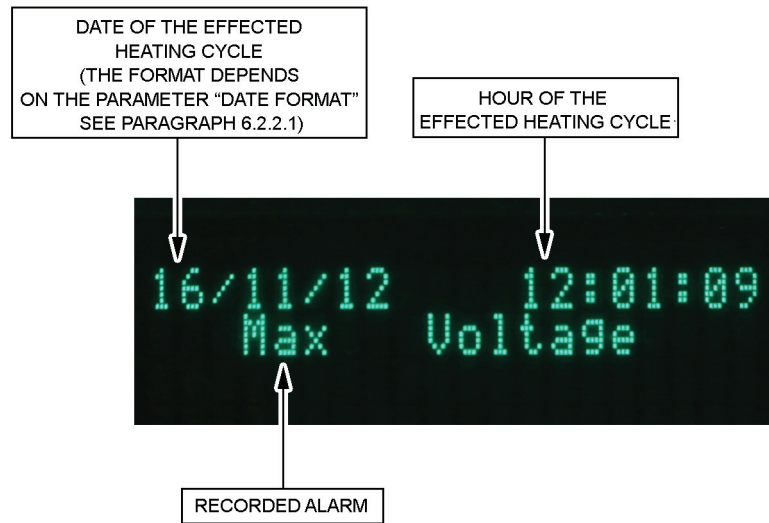

Figure 6.49 - Visualization of the alarm records

6.8.3 EVENTS LOGGER

In order to visualize the "EVENT" records follow the indications reported in the flow diagram illustrated in Figure 6.47.

The meaning of each field of the "EVENT" page is reported here-to-follow (see Figure 6.50).

The recorded events are:

- SET POINT CHANGED FROM xxxA TO yyyA = the generator output power set point is changed from xxxA to yyyA (see Paragraph 6.4.3.3);
- POWER ON = switching on of the generator;
- PF CORR. CHANGED TO ... = change of the parameter "PF Correction" (see Paragraph 6.4.5);
- DID YOU CHANGE THE COIL? = due to large variations of the voltage and current values asks if the coil has been replaced.

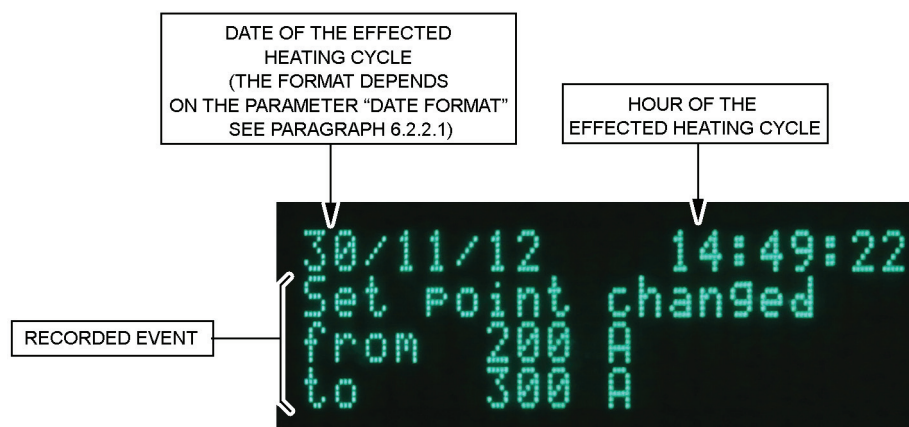

Figure 6.50 - Visualization of the "EVENT" records

6.9 DOWNLOAD THE LOGGER'S DATA FILE (OPTIONAL)

On the command and control panel (see Figure 6.51/1) of the Induction Heating Generator IHG 120CU an USB connector (3) may be installed to be used for downloading a file named LOG.CSV containing all the logger data. In order to correctly use this function it is advisable to utilize memories of 16GByte capacity maximum possibly empty.

The file LOG.CSV may be opened with any spreadsheet (Microsoft Excel) in which all data are separated by a comma.

The correct procedure for downloading that file is described here-to-follow:

- power on the generator (see Paragraph 6.4.1), do not start any heating cycle and, as the display (2) shows the main page (4), connect the memory to the USB connector (3);
- at the question "Export data?" (5), press "ENTER" (6) to confirm;
- when the writing "Export completed" - Remove the memory ! (7) appears disconnect the memory.

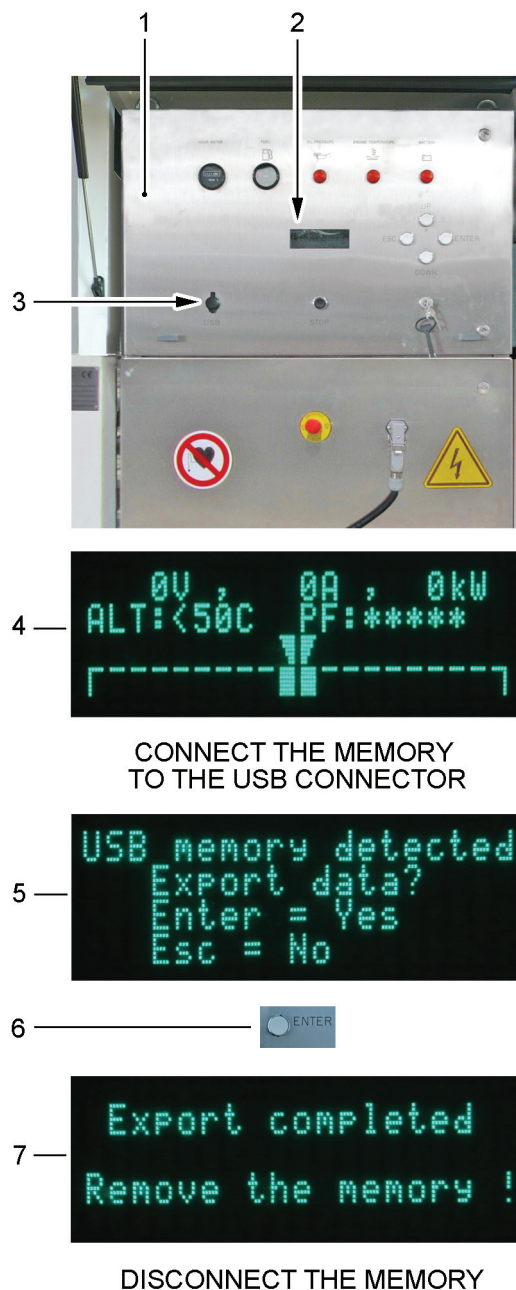

Figure 6.51 - Download the logger's data file (Optional)

Chapter

7

MAINTENANCE

7.1 GENERAL WARNINGS

In order to be sure to carry out a fully safe maintenance on the Induction Heating Generator IHG 120CU, the careful reading of this Chapter requires to have previously reached an exhaustive knowledge of all the contents of **Chapter 3 “Safety Rules”**.

7.2 INTRODUCTION

The Induction Heating Generator IHG 120CU was both designed and realized in order to reduce to the minimum the required maintenance interventions.

Before being delivered, the Induction Heating Generator IHG 120CU is tested at the **TeSi s.r.l.** factory, in order to be delivered to the Customer in ideal state.

In order to preserve the unit in that state and grant its fully failure-free operation, it's important to carry out both the routine maintenance and the preventive one, which are described in this Chapter, at the relevant due terms.

7.3 CUSTOMER/OPERATOR SERVICE

As **TeSi s.r.l.**'s purpose is to fully satisfy their Customers, don't hesitate to contact their Service in case of any possible problem.

In order to get an efficient Customer/Operator Service, please supply following information:

- a) Specify your name, address and phone number;
- b) Indicate both the model and serial number of your Induction Heating Generator IHG 120CU;
- c) Indicate the purchasing date and the unit operating hours;
- d) Describe the occurred anomaly.

At the end of this manual, a Chapter 10 “Maintenance Service Tables” was inserted, for recording the maintenance interventions.

After every intervention, the personnel who carried it out shall fill in every part the over mentioned Table, and apply both their signature and factory stamp, if the intervention was carried out by an external Company.

	<p>NOTE The non-execution of the scheduled maintenance, which can be proved by the records reported in the relevant Tables prepared for that purpose, will automatically lead to immediate warranty decay.</p>
---	---

It is besides worth to be reminded, that a maintenance correctly executed on the Induction Heating Generator IHG 120CU not only improves the unit reliability, but also preserves its long-term value.

7.4 AUTHORIZED PERSONNEL

- For small maintenance interventions..... **Operator**
- For mechanical maintenance interventions..... **Skilled maintainer, with a Mechanic qualification**
- For maintenance interventions on the electric plant... **Skilled maintainer, with an Electrician qualification**

7.5 ROUTINE MAINTENANCE

During normal use of the Induction Heating Generator IHG 120CU, in order to keep the machine in good condition, the operator must perform some simple routine maintenance operations, as indicated in Table 7.1.

Table 7.1 - Routine maintenance

PR. NR.	DESCRIPTION OF THE ACTIVITY	PERIODICITY	PARAGRAPH REFERENCE
1	Check and possibly clean the air intake grate	Daily	7.5.1
2	Check and possibly clean the air exhaust grate	Daily	7.5.2
3	Check the correct execution of the Automatic Test in the generator power supply phase	Daily - at starting	7.5.3
4	Clean the commands and controls situated on the command and control panel	Weekly	7.5.4
5	Check the correct operation of the exhaust valve, and possibly lubricate the relevant fastening pin	Weekly	7.5.5
6	Check the engine oil correct level and top it up, if necessary	Weekly	7.5.6
7	Check the engine coolant level and top it up, if necessary	Weekly	7.5.7
8	Check and possibly replace the air filter cartridge of the compressed air system (Optional)	Daily	7.5.8
9	Check and possibly clean the air filter desiccator of the compressed air system (Optional)	Monthly	7.5.9

7.5.1 CHECK AND POSSIBLY CLEAN THE AIR INTAKE GRATE

	<p>WARNING Before carrying out any operation, make sure the generator is off.</p>
---	--

	<p>PROHIBITION During the cleaning procedure, never directly spray water or liquids on the generator or on any of its parts.</p>
---	---

Visually check that the air intake grate (see Figure 7.1/1), isn't obstructed by any foreign body, such as wiping clothes, gloves, grease, earth, mud, etc..

Should the obstruction be simply caused by the presence of wiping clothes or gloves, provide to remove them; if, on the contrary, the air intake grate results to be obstructed by grease, earth or mud, clean the same ones by using a wiping cloth drenched in a water and cleansing liquid solution.



Figure 7.1 - Check and possibly clean the air intake grate

7.5.2 CHECK AND POSSIBLY CLEAN THE AIR EXHAUST GRATE

	<p>WARNING Before carrying out any operation, make sure the generator is off.</p>
---	--

	<p>PROHIBITION During the cleaning procedure, never directly spray water or liquids on the generator or on any of its parts.</p>
---	---

Visually check that the air exhaust grate (see Figure 7.2/1), isn't obstructed by any foreign body, such as wiping clothes, gloves, grease, earth, mud, etc..

Should the obstruction be simply caused by the presence of wiping clothes or gloves, provide to remove them; if, on the contrary, the air exhaust grate (1), results to be obstructed by grease, earth or mud, clean the same ones by using a wiping cloth drenched in a water and cleansing liquid solution.



Figure 7.2 - Check and possibly clean the air exhaust grate

7.5.3 CHECK THE CORRECT EXECUTION OF THE AUTOMATIC TEST IN THE GENERATOR POWER SUPPLY PHASE

On the command and control panel (see Figure 7.3/1), check for the correct execution of the automatic test in the generator power supply phase, by carrying out the operations indicated in Paragraph 6.4.1.

Check for the correct operation of the warning lights installed on the command and control panel (1).



Figure 7.3 - Check the correct execution of the automatic test in the generator power supply phase

7.5.4 CLEAN THE COMMANDS AND CONTROLS SITUATED ON THE COMMAND AND CONTROL PANEL

**WARNING**

Before carrying out any operation, make sure the generator is off.

**CAUTION**

During the cleaning procedure, never directly spray water or solvents on the commands and controls situated on the command and control panel, in order to clean them.

In order to carry out the commands' and controls' cleaning procedure, act as here following specified:

- by acting on the relevant handle (see Figure 7.4/1), after having removed the locking padlock (if present), open the transparent hatch (2), for protecting the command and control panel;
- by using a dry or slightly damp cloth, clean the commands and controls, as well as the panel itself;
- close the transparent hatch (2) by acting of the handle (1), and lock it by means of the locking padlock (if present).

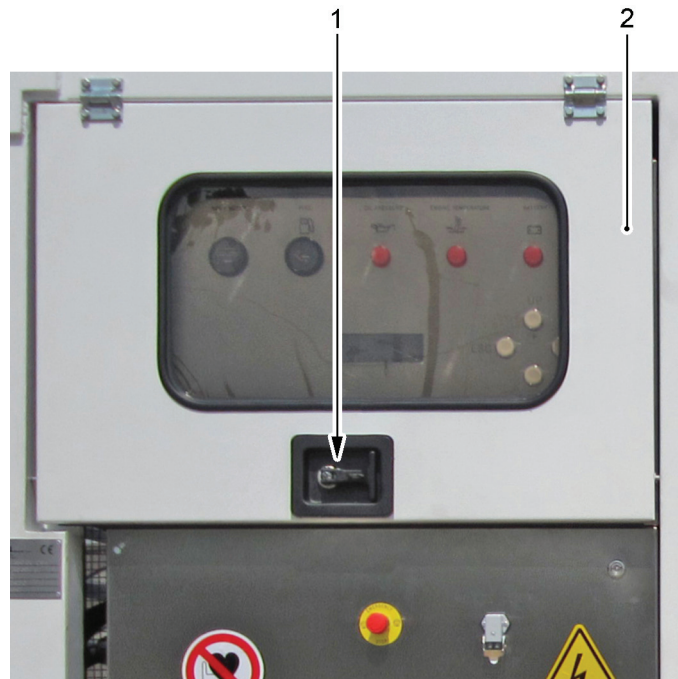

Figure 7.4 - Clean the commands and controls situated on the command and control panel

7.5.5 CHECK THE CORRECT OPERATION OF THE EXHAUST VALVE, AND POSSIBLY LUBRICATE THE RELEVANT FASTENING PIN

After having started the engine, check for the correct operation of the exhaust valve, which is situated on the exhaust pipe terminal (see. Figure 7.5/1), as here following indicated:

**WARNING**

The exhaust pipe terminal reaches very high temperatures. Therefore, before intervening, let it cool down and, besides, always wear the foreseen protective gloves.

- make sure that the exhaust pipe closing lid (2) can get immediately opened. Should the opening of the closing lid (2) result to be difficult, proceed:
 - to lubricate the fastening pin (3);
 - to carry out a visual check, in order to verify the absence of any bumps or mechanical solicitations with consequent deformations. Should any deformations be noticed, provide to restore the normal shape of the closing lid (2).
- repeat the check.

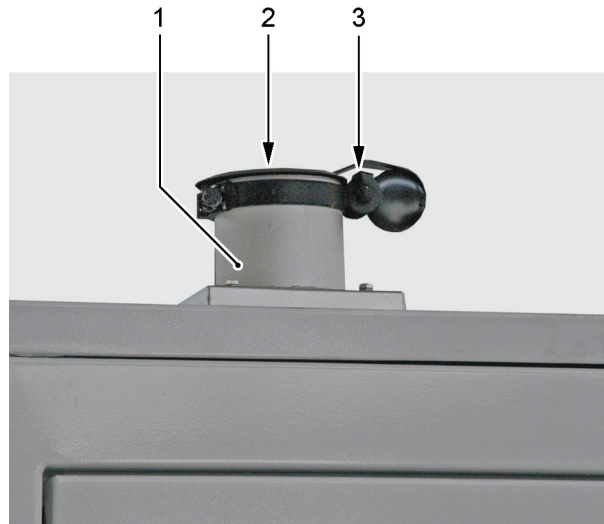

Figure 7.5 - Check the correct operation of the exhaust valve, and possibly lubricate the relevant fastening pin

7.5.6 CHECK THE ENGINE OIL CORRECT LEVEL AND TOPP IT UP, IF NECESSARY

	<p>WARNING Before carrying out any operation, make sure the generator is off.</p>
--	--

Carry out the check for the engine oil correct level, by proceeding as here following specified:

- open the access door to the engine (see Figure 7.6/1), which is situated on the rear part, by acting on the relevant handle (4), after having removed the locking padlock, in order to make it possible to accede to the oil level measuring dipstick (2), as well as to the engine oil filler cap (3);

	<p>NOTE For more detailed information, reference shall be made to the engine “Owners Manual - QSB4.5 and 6.7”, delivered by TeSi s.r.l. as a Joined Publication to this manual.</p>
--	--

- extract the engine oil level measuring dipstick (2) and check that the engine oil level is near notch corresponding to the maximum level, without ever exceeding it;
- should the oil level result to be incorrect, open the engine oil filler cap (3) and top up, until the maximum level notch is reached.

	<p>NOTE For topping up the engine oil level, exclusively use the oil prescribed by the engine manufacturer (see the engine “Owners Manual - QSB4.5 and 6.7”).</p>
--	--

- close the access door to the engine (1), by acting on the handle (4), and lock it by means of the locking padlock.

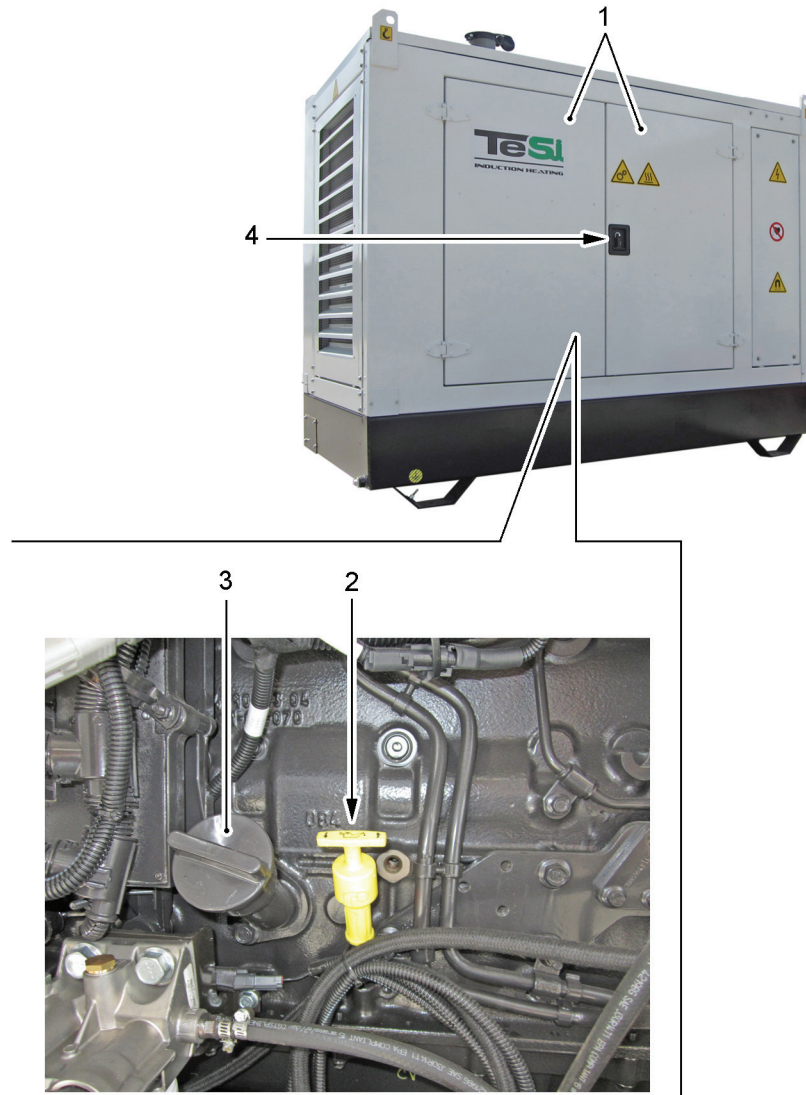

Figure 7.6 - Check the engine oil correct level and top it up, if necessary

7.5.7 CHECK THE ENGINE COOLANT CORRECT LEVEL AND TOP IT UP, IF NECESSARY



WARNING

Before carrying out any operation, make sure the generator is off from at least 10 minutes.

Carry out the check for the engine coolant correct level, by proceeding as here following specified:

- open the access door to the engine (see Figure 7.7/1), which is situated on the front part, by acting on the relevant handle (4), after having removed the locking padlock, in order to make it possible to accede to the engine coolant filler cap (2);



NOTE

For more detailed information, reference shall be made to the engine “Owners Manual - QSB4.5 and 6.7”, delivered by TeSi s.r.l. as a Jointed Publication to this manual.

- check the coolant level through the window (3);
- should the coolant level result to be incorrect refill it with adequate coolant.



NOTE

For topping up the engine coolant level, exclusively use the coolant prescribed by the engine manufacturer (see the engine “Owners Manual - QSB4.5 and 6.7”).



Figure 7.7 - Check the engine coolant correct level and top it up, if necessary

7.5.8 CHECK AND POSSIBLY REPLACE THE AIR FILTER CARTRIDGE OF THE COMPRESSED AIR SYSTEM (OPTIONAL)



WARNING
Before carrying out any operation, make sure the generator is off.

Carry out the check and possible replacement of the air filter cartridge of the compressed air system acting as here following specified:

- open the access door to the engine (see Figure 7.8/1), situated on the rear part, by acting on the relevant handle (4), after having removed the locking padlock;



NOTE
The filter is provided with an electrical timer.
The red light (3) of an electrically powered timer, housed in the unit, signals the necessity of replacement of the filter cartridge and the battery.

- check that the red light (3) on the top of the unit is not lit, on the contrary unscrew the bottom (2) of the housing and replace the inside filter cartridge and the battery;
- close the access door to the engine (1), by acting on the handle (4), and lock it by means of the locking padlock.



NOTE
It is also equipped with an automatic drain at the bottom (2).

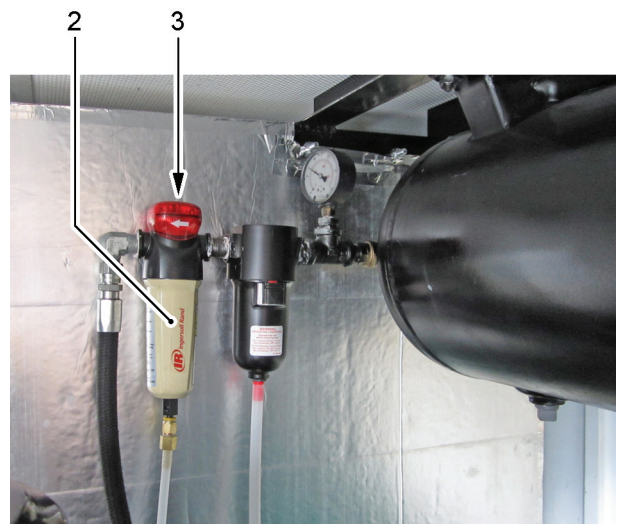

Figure 7.8 - Check and possibly replace the air filter cartridge of the compressed air system (Optional)

7.5.9 CHECK AND POSSIBLY CLEAN THE AIR FILTER DESICCATOR OF THE COMPRESSED AIR SYSTEM (OPTIONAL)



WARNING

Before carrying out any operation, make sure the generator is off.

Carry out the check and possible cleaning of the air filter desiccator of the compressed air system as here following specified:

- open the access door to the engine (see Figure 7.9/1), situated on the rear part, by acting on the relevant handle (3), after having removed the locking padlock;
- normally the air filter desiccator does not require maintenance because it has an automatic drain; however, perform a check by unscrewing the body (2) of that unit and possibly flush out manually any larger contaminants and clean;
- close the access door to the engine (1), by acting on the handle (3), and lock it by means of the locking padlock.

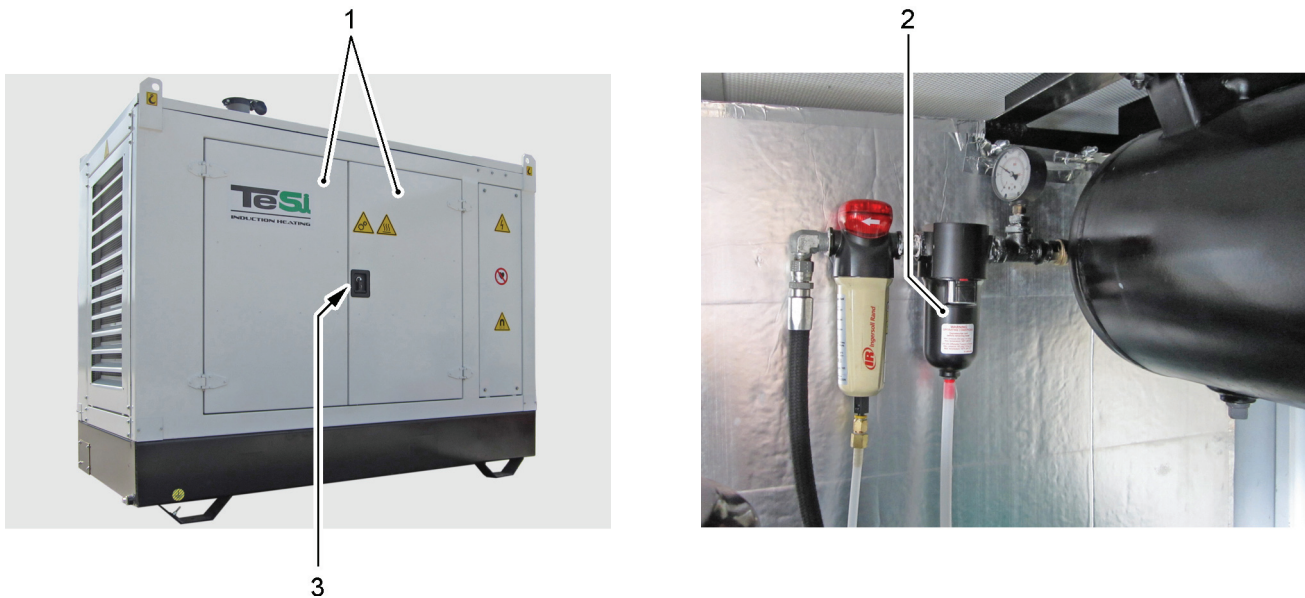

Figure 7.9 - Check and possibly clean the air filter desiccator of the compressed air system (Optional)

7.6 PERIODICAL PREVENTIVE MAINTENANCE



WARNING

Before intervening on any component, either mechanical or electrical, the maintenance liable technician must remove the ignition key, switch OFF the batteries switch for a better safety and preserve on himself the key until the maintenance intervention is over, and only after that he can restore the operation normal conditions, for carrying out the check on the Induction Heating Generator IHG 120CU.

That, in order to prevent anybody from restarting the Induction Heating Generator IHG 120CU without informing the personnel carrying out the maintenance intervention.

Besides, a warning notice shall be applied on the Induction Heating Generator IHG 120CU, informing that the same one is presently subjected to a maintenance intervention.

The maintenance liable technician is the main liable person for any possible accident which could occur during these operations; it is therefore recommended to execute the above described procedure, in order to prevent every possible serious and unpleasant inconveniences.

	<p>WARNING Before connecting an electric component, attentively examine the electric circuit; a wrong connection can lead to injuries and/or damages. That activity can be exclusively carried out by skilled personnel.</p>
---	---

In Table 7.2 and Table 7.3, the list of the scheduled maintenance activities, respectively of mechanical and electric type, are reported.

Table 7.2 - Mechanical scheduled maintenance

PR. NR.	DESCRIPTION OF THE ACTIVITY	PERIODICITY	MANUAL/PARAGRAPH REFERENCE
1	Replace the engine oil	Reference shall be made to the engine "Owners Manual - QSB4.5 and 6.7"	Reference shall be made to the engine "Owners Manual - QSB4.5 and 6.7"
2	Replace the engine oil filter	Reference shall be made to the engine "Owners Manual - QSB4.5 and 6.7"	Reference shall be made to the engine "Owners Manual - QSB4.5 and 6.7"
3	Replace the engine coolant	Reference shall be made to the engine "Owners Manual - QSB4.5 and 6.7"	Reference shall be made to the engine "Owners Manual - QSB4.5 and 6.7"
4	Replace the engine fuel filter	Reference shall be made to the engine "Owners Manual - QSB4.5 and 6.7"	Reference shall be made to the engine "Owners Manual - QSB4.5 and 6.7"
5	Replace the engine air filter	Reference shall be made to the engine "Owners Manual - QSB4.5 and 6.7"	Reference shall be made to the engine "Owners Manual - QSB4.5 and 6.7"
6	Check the belts, and, if necessary, replace them	Reference shall be made to the engine "Owners Manual - QSB4.5 and 6.7"	Reference shall be made to the engine "Owners Manual - QSB4.5 and 6.7"
7	Check the engine vibration-damping supports for condition, and make sure they are correctly tightened	Monthly	-

	<p>NOTE TeSi s.r.l. suggests to carry out the maintenance operations on the engine, enlisted in Table 7.2, at regular intervals no longer than 400 hours. Anyway, reference to the engine "Owners Manual - QSB4.5 and 6.7" shall be made, for exactly defining the correct intervals, according with the machine real use conditions.</p>
---	--

Table 7.3 - Electric preventive maintenance

PR. NR.	DESCRIPTION OF THE ACTIVITY	PERIODICITY	PARAGRAPH REFERENCE
1	Check the generator power connectors	Daily	7.6.1
2	Check the coil power connectors	Daily	7.6.1
3	Check the power connectors of the power supply cables between generator and coil	Daily	7.6.1

PR. NR.	DESCRIPTION OF THE ACTIVITY	PERIODICITY	PARAGRAPH REFERENCE
4	Check the wear of the insulating material of the power cables between generator and coil	Daily	7.6.2
5	Generally check the wear of the insulating material of the generator internal power cables and the tightening of the power wiring clamping screws and nuts	Every ~ 400 hours	7.6.3

7.6.1 CHECK THE POWER CONNECTORS, SITUATED ON THE GENERATOR, ON THE COIL AND ON THE POWER CABLES BETWEEN GENERATOR AND COIL

Make sure that the power connectors (see Figure 7.10/1), situated on the generator (2), on the coil (3) and on the power cables (4) between generator and coil, don't show any signs of damage due to over-temperatures (such as deformations, burnings, etc.), and that they are both clean and oxidation-free.



Figure 7.10 - Check the power connectors, situated on the generator, on the coil and on the power cables between generator and coil

7.6.2 CHECK THE WEAR OF THE INSULATING MATERIAL OF THE POWER CABLES BETWEEN GENERATOR AND COIL

Make sure that on the insulating material of the power cables between generator and coil there aren't any cracks, burnings, etc.. If some of these signs can be noticed, proceed to get them immediately repaired.

7.6.3 GENERALLY CHECK THE WEAR OF THE INSULATING MATERIAL OF THE GENERATOR INTERNAL POWER CABLES AND THE TIGHTENING OF THE POWER WIRING CLAMPING SCREWS AND NUTS

Make sure that on the insulating material of the generator internal power cables (see Figure 7.11) there aren't any cracks, burnings, etc.. If some of these signs can be noticed, proceed to get them immediately repaired. Besides, carry out the tightening of the power wiring screws and nuts.

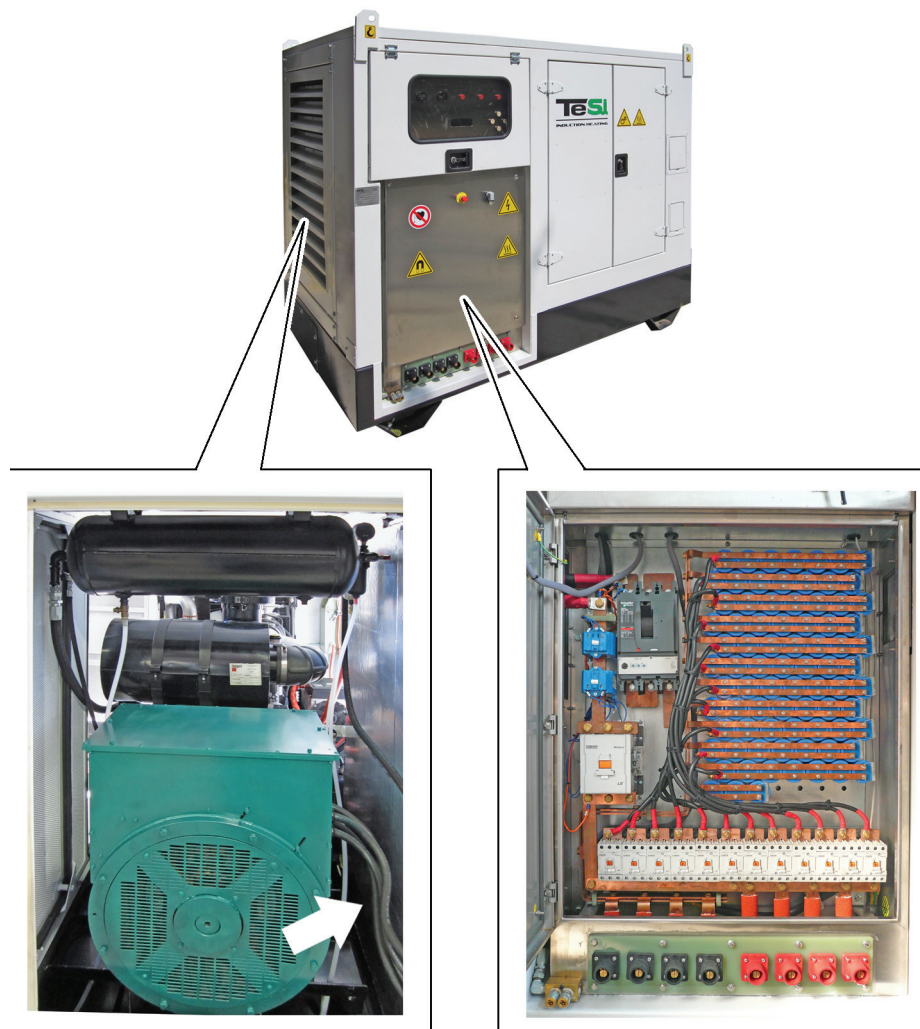

Figure 7.11 - Generally check the wear of the insulating material of the generator internal power cables and the tightening of the power wiring clamping screws and nuts

7.7 CORRECTIVE MAINTENANCE



WARNING

Before intervening on any component, either mechanical or electrical, the maintenance liable technician must remove the ignition key, switch OFF the batteries switch for a better safety and preserve on himself the key until the maintenance intervention is over, and only after that he can restore the operation normal conditions, for carrying out the check on the Induction Heating Generator IHG 120CU.

That, in order to prevent anybody from restarting the Induction Heating Generator IHG 120CU without informing the personnel carrying out the maintenance intervention.

Besides, a warning notice shall be applied on the Induction Heating Generator IHG 120CU, informing that the same one is presently subjected to a maintenance intervention.

The maintenance liable technician is the main liable person for any possible accident which could occur during these operations; it is therefore recommended to execute the above described procedure, in order to prevent every possible serious and unpleasant inconveniences.



WARNING

Before connecting an electric component, attentively examine the electric circuit; a wrong connection can lead to injuries and/or damages.

That activity can be exclusively carried out by skilled personnel.

In this Paragraph, the corrective maintenance operations are described, which the user's qualified technical personnel must observe, in order to carry out the repairs on the Induction Heating Generator IHG 120CU. In Table 7.4, the list of the corrective maintenance activities is reported.

Table 7.4 - Corrective maintenance

PR. NR.	DESCRIPTION OF THE ACTIVITY	PARAGRAPH REFERENCE
1	Electronic cards' replacement	7.7.1
2	Fuses F1, F2, F3, F4, F5 and F8 replacement	7.7.2
3	Fuse F0 replacement	7.7.3
4	Resetting of the automatic breaker "QS1"	7.7.4

7.7.1 ELECTRONIC CARDS' REPLACEMENT

	<p>WARNING All the operations on the electronic cards or, generally, inside the electric board, must be carried out when the generator is off.</p>
---	---

	<p>NOTE In case of any doubt, before intervening on the electronic cards, contact the TeSi s.r.l. "After-Sales Technical Service".</p>
---	---

	<p>NOTE As the removal/installation procedures of the electronic cards (see Figure 7.12/5) and (6) are identical, here following the removal/installation procedure of the CPU electronic card (6) is reported.</p>
---	--

a) Removal

- 1) By acting on the relevant handle (see Figure 7.12/1), after having removed the locking padlock (if present) open the transparent hatch (2), for protecting the command and control panel.
- 2) Unlock the lockers (4), fastening the command and control panel (3) to the structure.

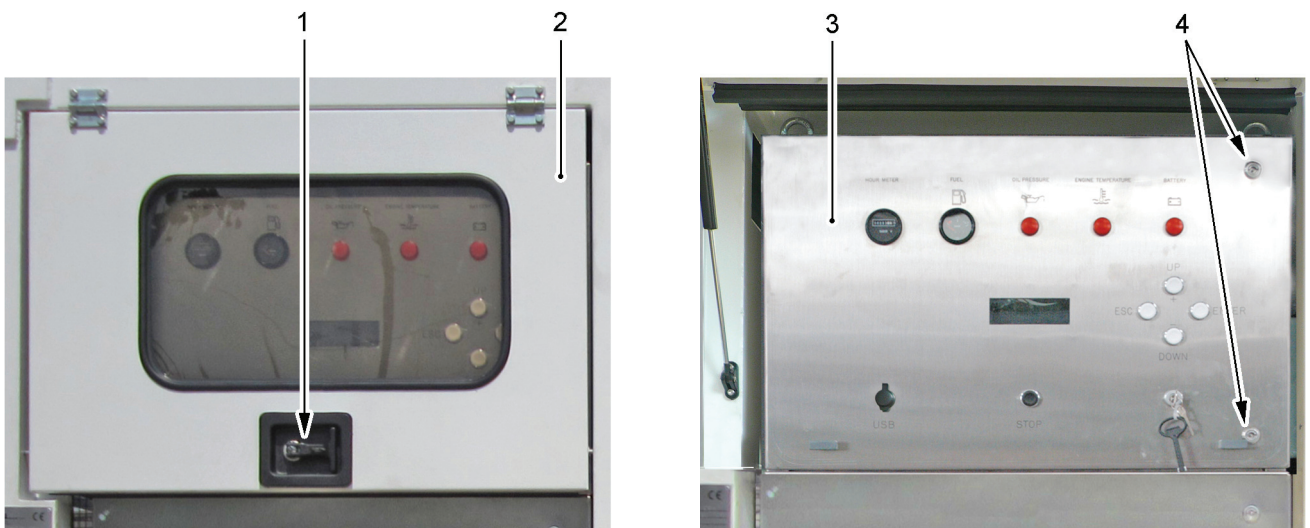

*Figure 7.12 - Electronic cards' replacement
(Sheet 1 of 2)*

- 3) Open the command and control panel (3).
- 4) Disconnect the connectors (7) from the CPU electronic card (6).



NOTE

Intervene on the electronic cards, only after having taken note of all the connections to be restored and relevant polarities.

- 5) Unscrew the screws fastening the CPU electronic card (6); then remove the screws and the CPU electronic card (6).

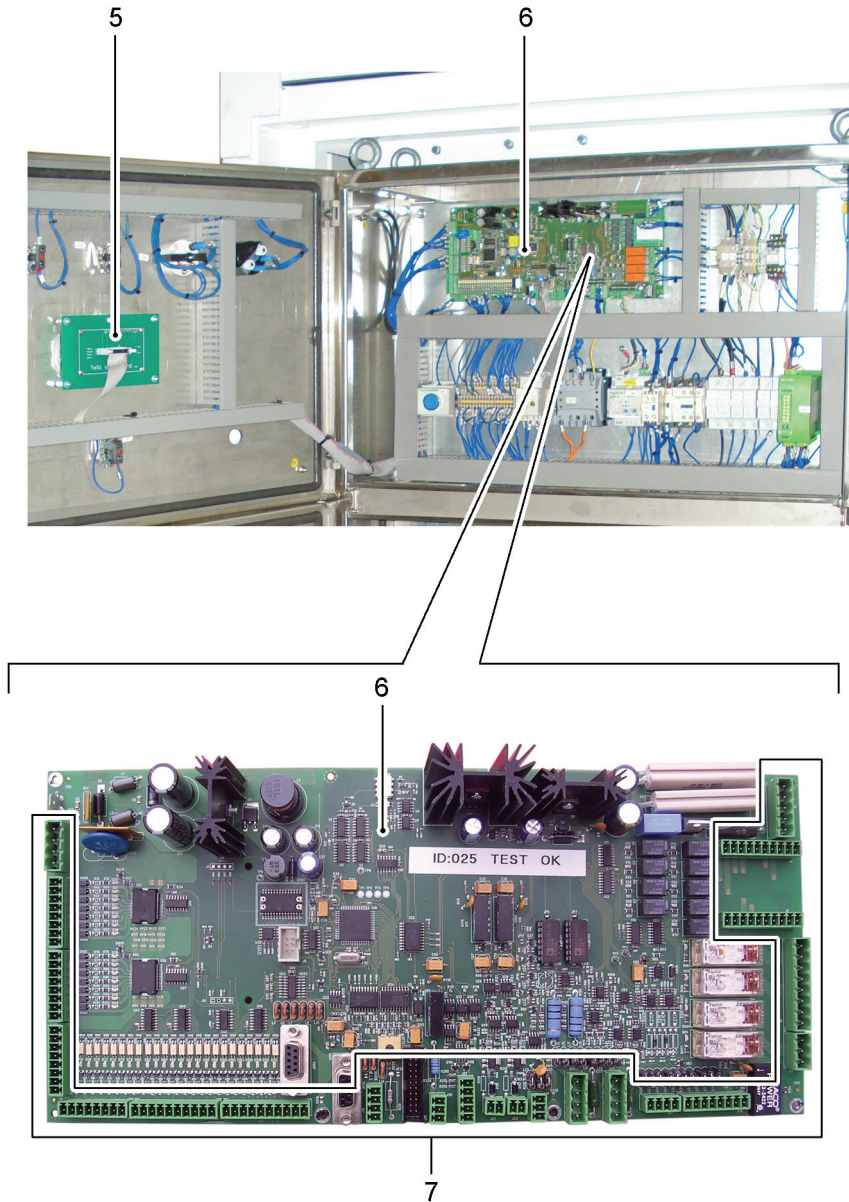

Figure 7.12 - Electronic cards' replacement
(Sheet 2 of 2)

b) Installation

- 6) Install a new CPU electronic card (6), by carrying out, in reverse order, the procedures described in the previous steps from 5) to 1).

7.7.2 FUSES F1, F2, F3, F4, F5 AND F8 REPLACEMENT

	<p>WARNING Before carrying out any operation, make sure the generator is off.</p>
---	--

	<p>NOTE As the removal/installation procedures of fuses F1 (see Figure 7.13/6), F2 (7), F3 (8), F4 (11), F5 (10) and F8 (9) are identical, here following the removal/installation procedure of fuse F1 (6) is reported.</p>
---	---

a) Removal

- 1) By acting on the relevant handle (see Figure 7.13/1), after having removed the locking padlock (if present) open the transparent hatch (2), for protecting the command and control panel, in order to make it possible to accede to the fuses F1 (6), F2 (7), F3 (8), F4 (11), F5 (10) and F8 (9).
- 2) Unlock the lockers (4), fastening the command and control panel (3) to the structure.

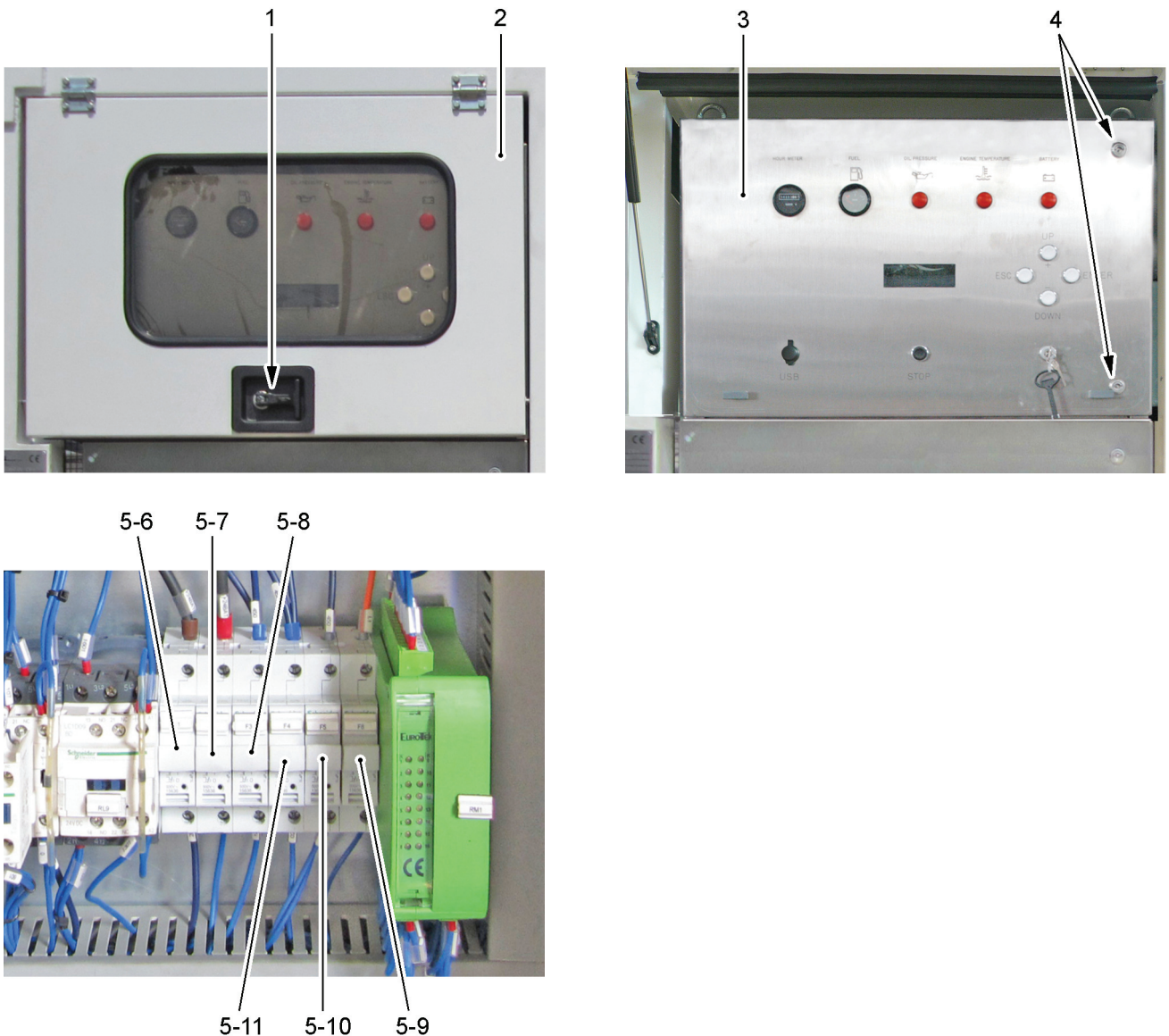

Figure 7.13 - Fuses F1, F2, F3, F4, F5 and F8 replacement

- 3) Open the command and control panel (3).
- 4) Remove the protective cover (5) and extract the fuse F1 (6).

b) Installation

- 5) Replace the fuse F1 (6) with another one having the same characteristics.
- 6) Proceed to perform the installation, by carrying out, in reverse order, the procedures described in the previous steps from 4) to 1).

7.7.3 FUSE F0 REPLACEMENT



WARNING
Before carrying out any operation, make sure the generator is off.

a) Removal

- 1) Open the access door to the engine (see Figure 7.14/1), situated on the front part, by acting on the relevant handle (4), after having removed the locking padlock, in order to make it possible to accede to the fuse F0 (3).
- 2) Remove the protective cover (2) and extract the fuse F0 (3).

b) Installation

- 3) Replace the fuse F0 (3) with another one having the same characteristics, and re-position the protective cover (2).
- 4) Close the access door to the engine (1), by acting on the handle (4), and lock it by means of the locking padlock.

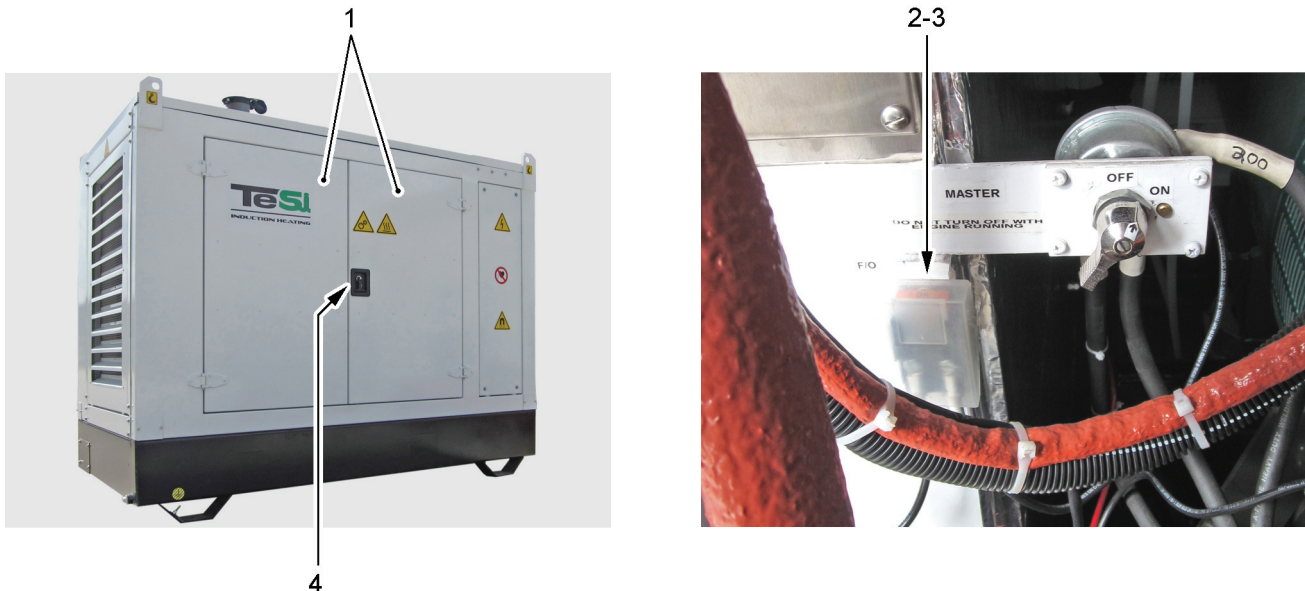

Figure 7.14 - Fuse F0 replacement

7.7.4 RESETTING OF THE AUTOMATIC BREAKER “QS1”



WARNING

Before carrying out any operation, make sure the generator is off.

a) Removal

- 1) Unlock the lockers that fasten the door (1), situated on the left side of the generator, in order to make it possible to accede to the alternator connection box (4)
- 2) Open the door (1).

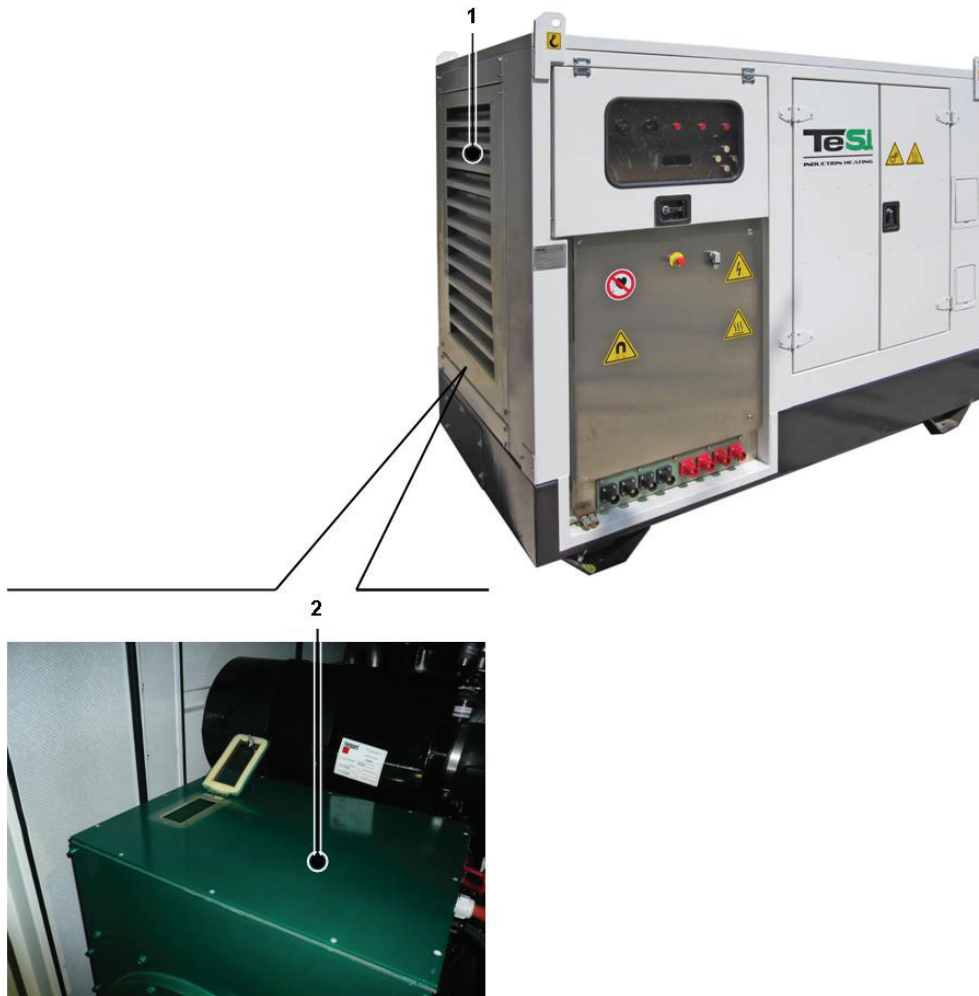

*Figure 7.15 - Reset of the automatic breaker “QS1”
(Sheet 1 of 2)*

- 3) Check that the lever (4) of the automatic breaker "QS1" (3) is open "O".
- 4) Press the "RESET" pushbutton (5) on the automatic breaker "QS1" (3).
- 5) Set the lever (4) to the position "1" closed.

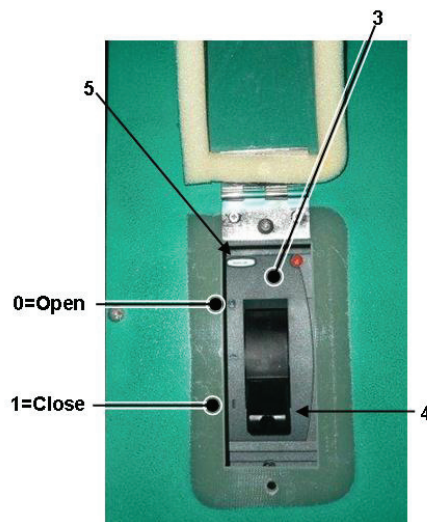

*Figure 7.15 - Reset of the automatic breaker "QS1"
(Sheet 2 of 2)*

b) Installation

- 6) Proceed to perform the installation, by carrying out, in reverse order, the procedure described in the previous step 1).

Chapter

8

DIAGNOSTICS

8.1 GENERAL

In this Chapter, two types of troubleshooting concerning the Induction Heating Generator IHG 120CU are considered: the first one, which allows to directly visualize on the display, situated on the command and control panel, through written messages, failures and anomalies, the second one, on the contrary, those failures which result to be statistically the most common ones, or some difficulties which the operator can meet during the use of the generator itself.

8.1.1 INCONVENIENCES WHICH CAN BE VISUALIZED ON THE DISPLAY

Tables 8.1 and 8.2 supply the list of the inconveniences and of the alarms, respectively, which can be visualized on the display during the use of the Induction Heating Generator IHG 120CU, associating to each of them the possible causes and the relevant remedies.



NOTE

The operations must be exclusively carried out by Technicians opportunely trained on diagnostics.

Table 8.1 - Inconveniences which can be visualized on the display

INCONVENIENCE	OPERATING LOGIC	POSSIBLE CAUSE	REMEDY
Display message: “CHECK EMERGENCY BUTTONS” .	First message displayed when the ignition key is switched in the first position and at least emergency button is pressed or the remote control is not connected.	At least one emergency button is pressed or the remote control is not connected. The ground fault switch “QM1” (see Figure 8.1/1) is not working.	Check the emergency button on the command and control panel, on the remote control and the remote control connection. Check that the green light (see Figure 8.1/2) is on; otherwise, check the presence of the 24V supply at pins A1 e A2. If the 24V supply is present, replace the ground fault switch “QM1” (1).
Display message: “EMERGENCY BUTTON” .	At alarm actuation, the electronic control system stops the heating cycle and the engine.	One or both the emergency buttons are pressed or the remote control is disconnected.	Check the emergency button on the command and control panel, on the remote control and the remote control connection.

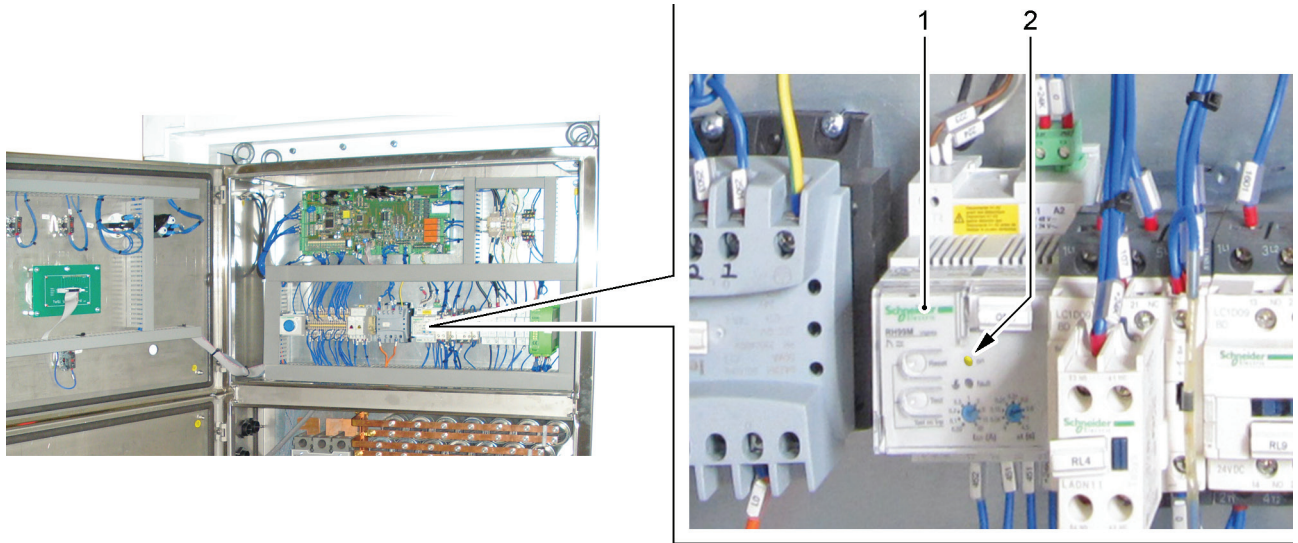



Figure 8.1 - Ground fault switch “QM1”

INCONVENIENCE	OPERATING LOGIC	POSSIBLE CAUSE	REMEDY
Display message: “CYCLE TIME ELAPSED” .	The heating time is elapsed and the heating cycle is stopped by the timer.	The automatic heating cycle stop with the timer is set ON. The heating time is elapsed and the heating cycle is stopped by the timer.	See Paragraph 6.4.3.2 to set ON or OFF the heating timer.
Display message: “TEMPERATURE REACHED” (optional).	The required temperature has been reached on the pipe and the heating cycle has automatically stopped.	The heating cycle automatic stop is active once the preset temperature has been reached.	In order to set to “ON” or “OFF” the parameter “Temperature probe - Mode” (Optional) refer to Paragraph 6.4.6.4.
Display message: “THE COIL IS OPEN” .	Clamp coil electric circuit is open. If the engine is idle running, it impedes the heating cycle getting started. At alarm actuation, the electronic control system not allows to start the heating cycle.	The clamp coil contacts aren't fully closed or they are damaged. The power cables' connections aren't correct. Either the power cables or the connectors are damaged. A failure inside the closing control circuit took place. Check the F8 fuse.	Open and close the clamp coil, by checking that the contacts aren't damaged and that they are correctly aligned. Make sure that the power cables are correctly connected (see Paragraph 5.4.5). Check the closing control circuit. Replace the F8 fuse (see Paragraph 7.7.2).

INCONVENIENCE	OPERATING LOGIC	POSSIBLE CAUSE	REMEDY
Display message: “MAX VOLTAGE” .	Generator output maximum voltage was reached. At alarm actuation, the electronic control system stops the heating cycle.	<ul style="list-style-type: none"> A) The pipe is not on the coil. B) The generator power factor correction wasn't correctly performed (see Paragraph 6.4.5). C) Working parameters were incorrectly set. D) Output power circuit wasn't correctly connected or isn't closed (see previous step). E) A failure to the control circuit and/or to the electronic cards took place. 	<ul style="list-style-type: none"> A) Put the pipe inside the coil. B-C) Check both the operation settings (see Paragraph 6.4.3) and the generator power factor correction (see Paragraph 6.4.5). D) Check for the correct connection of the power connectors, realizing the connection between coil and generator (see Paragraph 5.4.5). E) If the problem persists, check, if possible, the control circuit or contact the TeSi s.r.l. "After-Sales Technical Service".
Display message: “MAX CURRENT” .	Generator output maximum current was reached. At alarm actuation, the electronic control system stops the heating cycle.	<ul style="list-style-type: none"> A) The output power circuit isn't correctly connected and results being short-circuited. B) The generator power factor correction wasn't correctly performed (see Paragraph 6.4.5). C) Working parameters were incorrectly set. D) A failure to the control circuit and/or to the electronic cards took place. 	<ul style="list-style-type: none"> A) Check for the correct connection of the power connectors, realizing the connection between coil and generator (see Paragraph 5.4.5). B-C) Check both the operation settings (see Paragraph 6.4.3) and the generator power factor correction (see Paragraph 6.4.5). D) If the problem persists, check, if possible, the control circuit or contact the TeSi s.r.l. "After-Sales Technical Service".

INCONVENIENCE	OPERATING LOGIC	POSSIBLE CAUSE	REMEDY
Display message: “ LOW POWER ”. 	Alternator temperature is high (beyond 125 °C). At alarm actuation, the electronic control system reduces the power supplied by the generator to 66%. The engine keeps high running, until the alternator temperature drops below 110 °C.	Such condition can take place after long heating cycles at maximum power and by high ambient temperatures. Generator was used with duty cycle higher than allowed. Ventilation grates are obstructed.	Such alarm doesn't impede the generator operation, but temporarily reduces its power. Make sure that the ventilation grates aren't obstructed. If possible, reduce either the power supplied or the duty cycle.
Display message: “ MAX ALTERNATOR TEMP ”.	Alternator max. temperature (145 °C) was reached. At alarm actuation, the electronic control system stops the heating cycle.	The alternator exceeded its maximum working temperature. That condition is only rarely reached, but it can take place by particular use conditions (high ambient temperatures and long operating cycles). <p style="text-align: center;">NOTE</p> Reference shall also be made to the conditions specified in the step “ Alternator high temperature (beyond 125 °C) ”.	Let the engine run idle for at least 15 minutes. When this time will have elapsed, it is suggested to reduce the current of at least 15%. <p style="text-align: center;">CAUTION</p> If that alarm occurs more than once, promptly contact the TeSi s.r.l. “ After-Sales Technical Service ” and don't use the generator before having identified the causes of the anomaly.
Display message: “ MAIN ALTERN. PROT. ”.	Automatic (thermomagnetic) breaker “QS1” intervened. At alarm actuation, the electronic control system stops the heating cycle.	The automatic (thermomagnetic) breaker “QS1” is intervened for protecting the generator alternator probably due to the opening of the coil during the heating cycle.	Reset the automatic (thermomagnetic) breaker “QS1” according to the instructions supplied at Paragraph 7.7.4.

INCONVENIENCE	OPERATING LOGIC	POSSIBLE CAUSE	REMEDY
<p>Display message: “GROUND FAULT”.</p>	<p>Ground leakage. At alarm actuation, the electronic control system stops the heating cycle and the engine.</p>	<p>The differential gear protection device intervened because of:</p> <p>A) electric insulation problems in the power section wiring;</p> <p>B) insulation problem inside the alternator;</p> <p>C) connection interrupted between differential ground fault switch (see Figure 8.2b/3) and differential ground fault switch current probe (see Figure 8.2a). In this case the red light “Fault” is blinking (see Figure 8.2b/4) on the ground fault switch “QM1” (3).</p> <p>PROHIBITION Don't restart the generator before having localized the alarm causes.</p>	<p>A) carefully check the wiring of the power section, in order to exclude any possible insulation problems;</p> <p>B) verify that the alternator doesn't show any insulation problem;</p> <p>C) check the connection between differential ground fault switch (pins T1 and T2) (see Figure 8.2b/1 and 2) and differential ground fault switch current probe (pins 1 and 2) (see Figure 8.2a).</p> <p>NOTE In order to perform some of the above described checks, it could be necessary to use the relevant suitable measuring instruments.</p> <p>CAUTION That type of failure could require the intervention of the TeSi s.r.l. “After-Sales Technical Service”.</p>

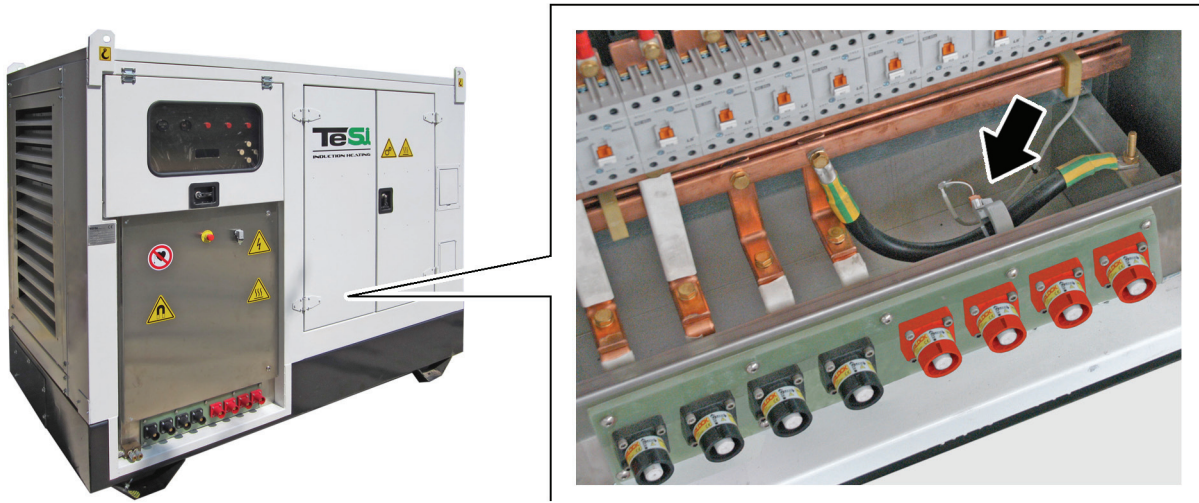

a. Differential ground fault switch current probe

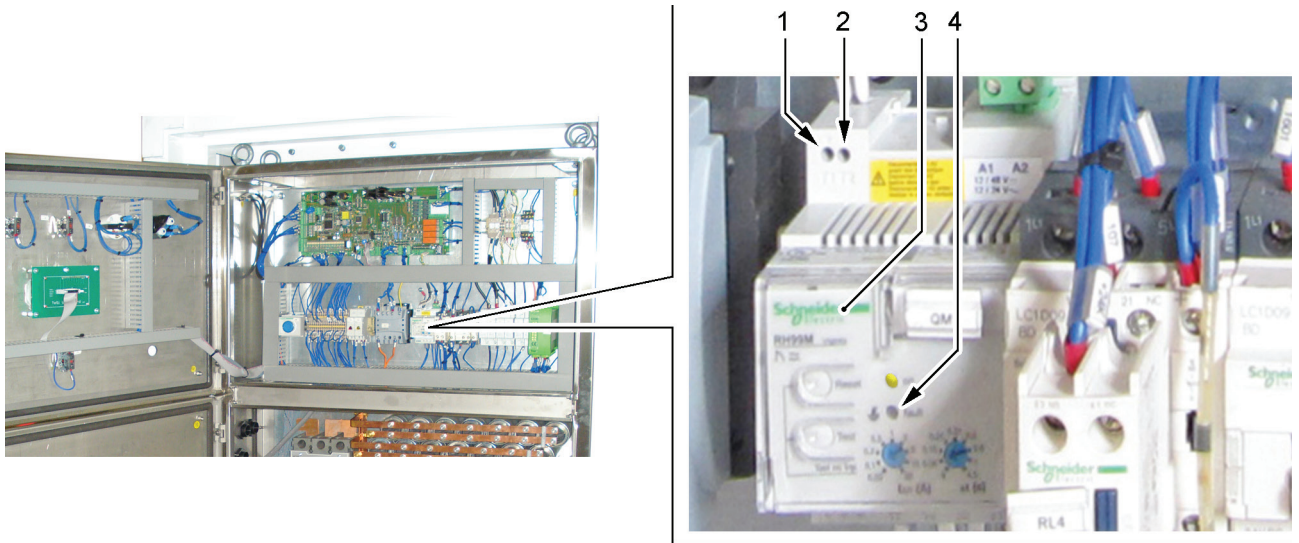

b. Differential ground fault switch

Figure 8.2 - Ground fault

INCONVENIENCE	OPERATING LOGIC	POSSIBLE CAUSE	REMEDY
<p>Display message: “CURRENT FEEDBACK”.</p>	<p>The output current is below 50 Amperes. At alarm actuation, the electronic control system stops the heating cycle.</p>	<p>Incorrect operation of the regulation system of the current delivered to the coils:</p> <ul style="list-style-type: none"> - a problem to the current measuring wiring took place; - a failure to the control circuit and/or to the electronic cards took place; - a failure either to the alternator excitation circuit connection or to the alternator took place; - the main power switch is on failure. 	<p>Inside the electric board, make sure that the measuring and excitation circuit wirings don't show any anomalies (see Wiring Diagram). Check the correct wiring of the excitation cables on the alternator. Make sure that the main power switch RL1 correctly operates. If the problem persists, check, if possible, the control circuit or contact the TeSi s.r.l. “After-Sales Technical Service”.</p> <p style="text-align: center;">CAUTION</p> <p>That type of failure could require the intervention of the TeSi s.r.l. “After-Sales Technical Service”.</p>
<p>Display message: “VOLTAGE FEED-BACK”.</p>	<p>The output voltage is below 20 Volts. At alarm actuation, the electronic control system stops the heating cycle.</p>	<p>Incorrect operation of the control system of the voltage delivered to the coils:</p> <ul style="list-style-type: none"> - the output power circuit isn't correctly connected and results being short-circuited; - the generator power factor correction wasn't correctly performed (see Paragraph 6.4.5); - a problem to the control system wiring took place; - a failure to the control circuit and/or to the electronic cards took place. 	<p>Check for the correct connection of the power connectors, realizing the connection between coil and generator (see Paragraph 5.4.5). Check both the operation settings (see Paragraph 6.4.3) and the generator power factor correction (see Paragraph 6.4.5). Inside the electric board, make sure that the measuring circuit wirings don't show any anomalies (see Wiring Diagram). If the problem persists, check, if possible, the control circuit or contact the TeSi s.r.l. “After-Sales Technical Service”.</p> <p style="text-align: center;">CAUTION</p> <p>That type of failure could require the intervention of the TeSi s.r.l. “After-Sales Technical Service”.</p>

INCONVENIENCE	OPERATING LOGIC	POSSIBLE CAUSE	REMEDY
Display message: “BAD PF: REMOVE 1 CAP” .	The generator is equipped with an automatic power factor correction system, but this is set on manual mode (“PF CORRECTION = MAN”) parameter. At alarm actuation, the electronic control system stops the heating cycle.	The PF value is lower than the 0.9 on the capacitive side. Trouble on the PF measuring circuit.	Verify the operating settings and the power factor correction of the generator, by reducing of ½ or of 1 bank the No. of banks of inserted capacitors.
Display message: “BAD PF: ADD 1 CAP” .	The generator is equipped with an automatic power factor correction system, but this is set on manual mode (“PF CORRECTION = MAN”) parameter. At alarm actuation, the electronic control system stops the heating cycle.	The PF value is lower than the 0.9 on the inductive side. Trouble on the PF measuring circuit.	Verify the operating settings and the power factor correction of the generator, by increasing of ½ or of 1 bank the No. of banks of inserted capacitors.
Display message: “VOLTAGE SENSE FAULT” .	At alarm actuation, the electronic control system stops the heating cycle.	Incorrect operation of the output voltage control system. That alarm signals the intervention of the auxiliary control device. A failure to the control circuit and/or to the electronic cards took place.	Check, if possible, the control circuit of the output voltage (see Wiring Diagram), or contact the TeSi s.r.l. “After-Sales Technical Service”. <p style="text-align: center;">CAUTION</p> <p>That type of failure could require the intervention of the TeSi s.r.l. “After-Sales Technical Service”.</p>
Display message: “CURRENT SENSE FAULT” .	At alarm actuation, the electronic control system stops the heating cycle.	Incorrect operation of the output current control system. That alarm signals the intervention of the auxiliary control device. A failure to the control circuit and/or to the electronic cards took place.	Check, if possible, the control circuit of the output current (see Wiring Diagram), or contact the TeSi s.r.l. “After-Sales Technical Service”. <p style="text-align: center;">CAUTION</p> <p>That type of failure could require the intervention of the TeSi s.r.l. “After-Sales Technical Service”.</p>

INCONVENIENCE	OPERATING LOGIC	POSSIBLE CAUSE	REMEDY
Display message: “EXC SHORT CIRCUIT” .	At alarm actuation, the electronic control system stops the heating cycle.	There is a short circuit on the main alternator excitation circuit.	Check, if possible, the main alternator excitation circuit. Check the wires 0203 and 0204 from the main card on the control box to the main alternator. (see Wiring Diagram), or contact the TeSi s.r.l. "After-Sales Technical Service"
Display message: “ENGINE OVER-HEATED” .	At alarm actuation, the engine overheating warning light lights up, the electronic control system stops the heating cycle and the engine.	The engine reached its maximum working temperature. That condition can take place after some long heating cycles at the maximum power, by high ambient temperatures. Other possible causes are: use of the generator with a duty cycle higher than the allowed one. Ventilation grates obstructed. Problems either to the engine or to its cooling down system.	As soon as the normal temperature is reached, the system gets automatically restored. Make sure the ventilation openings aren't obstructed. If possible, reduce either the power delivered or the duty cycle. If the problem persists, reference shall be made to the engine "Owners Manual - QSB4.5 and 6.7", for the anomalies possibly occurring to the same one.
Display message: “LOW OIL PRESSURE” .	At alarm actuation, the electronic control system stops the heating cycle and the engine.	The engine oil pressure is under normal value.	Check the engine oil level (see Paragraph 7.5.6). If the problem persists, reference shall be made to the engine "Owners Manual - QSB4.5 and 6.7", for the anomalies possibly occurring to the same one.
Display message: “LOW WATER LEVEL” .	At alarm actuation, the electronic control system stops the heating cycle and the engine.	The engine cooling water is under normal value.	Check the engine cooling water level (see Paragraph 7.5.7). If the problem persists, reference shall be made to the engine "Owners Manual - QSB4.5 and 6.7", for the anomalies possibly occurring to the same one.

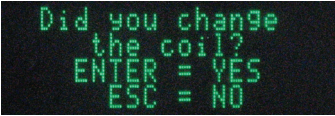
INCONVENIENCE	OPERATING LOGIC	POSSIBLE CAUSE	REMEDY
Display message: “BUS J1939 MISSING” .	At alarm actuation, the electronic control system stops the heating cycle and the engine.	The data link CAN BUS J1939 is not working.	Check conditions of connector “J19” (see Figure 8.3a/1) positioned on the CPU control card (2), of connector “CN 10” (see Figure 8.3b/4) situated inside the structure (3) and of the connector (see Figure 8.4/2) of the engine control unit (1).
Display message: “ENGINE” . 	Presence of active engine alarm.	Depending on the alarm visualized on the display (see Table 8.2).	Stop the heating cycle: the display will show the engine alarm with the relevant codes FMI and SPN. For additional information see Table 8.2.
Display message: “DID YOU CHANGE THE COIL?” . 	At alarm actuation, the electronic control system stops the heating cycle.	An alarm which can be caused by the generator load variation (new coil) has been actuated. In this case the generator asks us if the coil has been changed.	If the answer is positive (ENTER) at the subsequent heating cycle the generator will provide an automatic adjustment of the power factor (PF). If the answer is negative (ESC) the generator will display the alarm. At this point it will be necessary to eliminate the alarm situation.

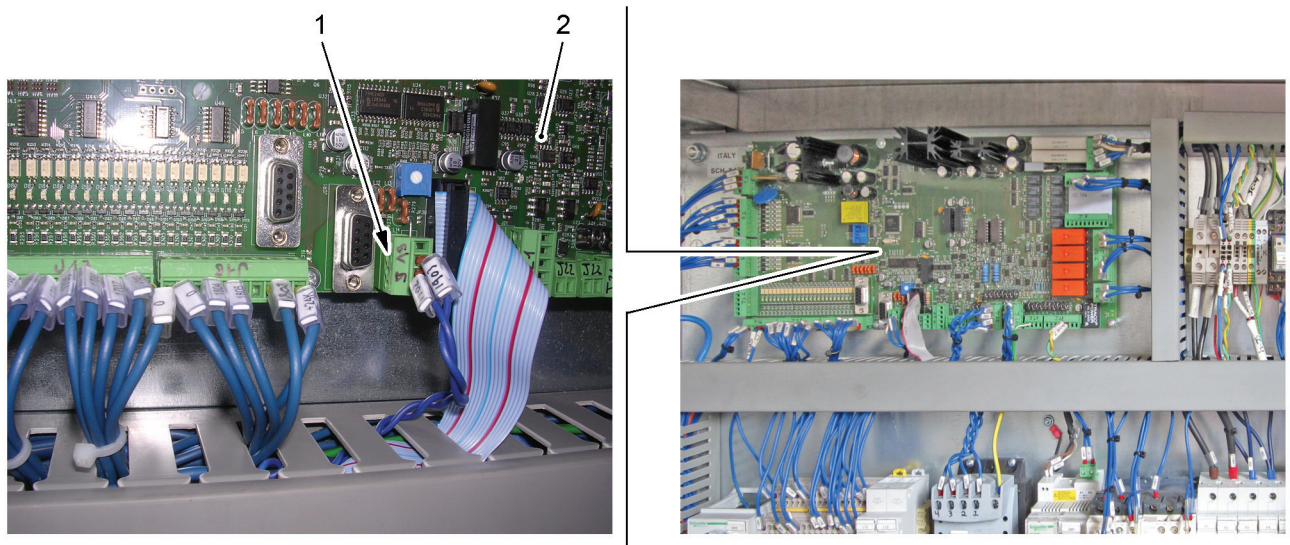

a. Connector “J19”

Figure 8.3 - Connectors “J19” and “CN 10”
(Sheet 1 of 2)

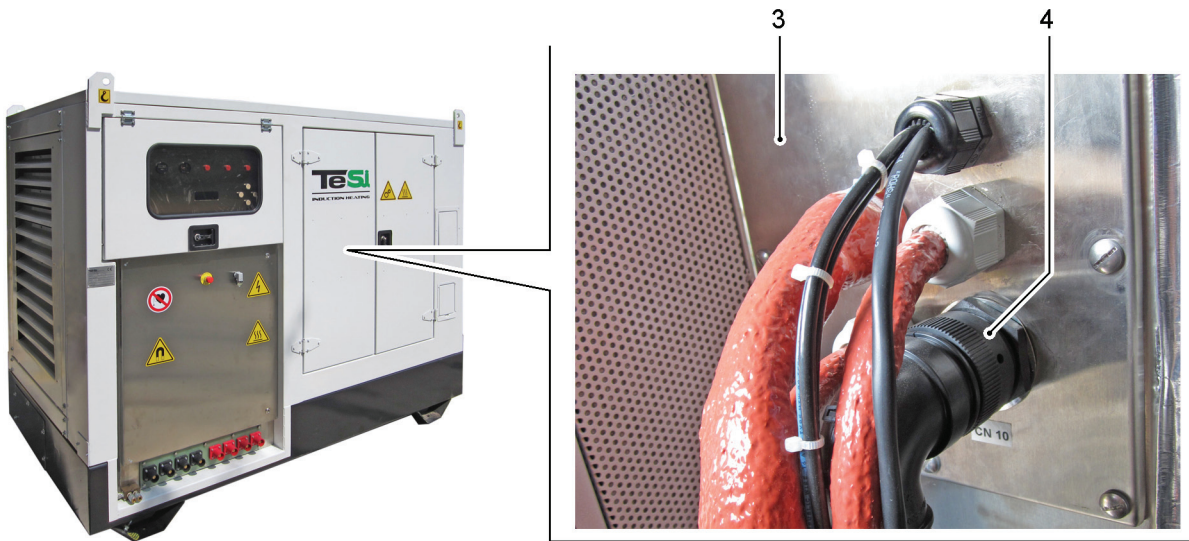

b. Connector "CN 10"

Figure 8.3 - Connectors "J19" and "CN 10"
(Sheet 2 of 2)

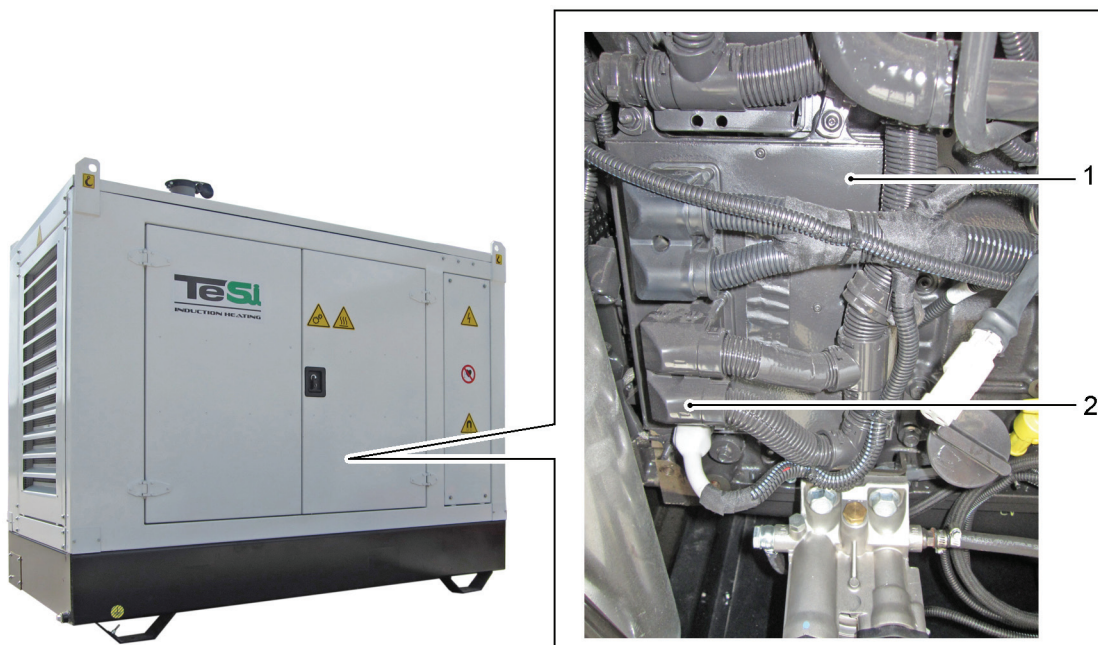

Figure 8.4 - Connector of the engine control unit

Table 8.2 - Engine alarms which can be visualized on the display

J1939 SPN	J1939 FMI	J1939 SPN Description	Cummins Description
629	12	Controller #1	Engine Control Module Critical internal failure - Bad intelligent Device or Component
612	2	System Diagnostic Code # 2	Engine Speed/Position Sensor Circuit lost both of two signals from the magnetic pickup sensor - Data Erratic, Intermittent, or incorrect
102	3	Boost Pressure	Intake Manifold Pressure Sensor Circuit - Voltage Above Normal, or Shorted to High Source
102	4	Boost Pressure	Intake Manifold Pressure Sensor Circuit - Voltage Below Normal, or Shorted to Low Source
102	16	Boost Pressure	Intake Manifold 1 Pressure - Data Valid but Above Normal Operational Range - Moderately Severe Level
91	3	Accelerator Pedal Position	Accelerator Pedal or Lever Position Sensor Circuit - Voltage Above Normal, or Shorted to High Source
91	4	Accelerator Pedal Position	Accelerator Pedal or Lever Position Sensor Circuit - Voltage Below Normal, or Shorted to Low Source
974	3	Remote Accelerator	Remote Accelerator Pedal or Lever Position Sensor Circuit - Voltage Above Normal, or Shorted to High Source
974	4	Remote Accelerator	Remote Accelerator Pedal or Lever Position Sensor Circuit - Voltage Below Normal, or Shorted to Low Source
100	3	Engine Oil Pressure	Oil Pressure Sensor Circuit - Voltage Above Normal, or Shorted to High Source
100	4	Engine Oil Pressure	Oil Pressure Sensor Circuit - Voltage Below Normal, or Shorted to Low Source
100	18	Engine Oil Pressure	Oil Pressure Low - Data Valid but Below Normal Operational Range - Moderately Severe Level
110	3	Engine Coolant Temperature	Coolant Temperature Sensor Circuit - Voltage Above Normal, or Shorted to High Source
110	4	Engine Coolant Temperature	Coolant Temperature Sensor Circuit - Voltage Below Normal, or Shorted to Low Source
110	16	Engine Coolant Temperature	Coolant Temperature High - Data Valid but Above Normal Operational Range - Moderately Severe Level
91	1	Accelerator Pedal Position	Accelerator Pedal or Lever Position Sensor Circuit - Abnormal Frequency, Pulse Width, or Period
91	0	Accelerator Pedal Position	Accelerator Pedal or Lever Position Sensor Circuit - Abnormal Frequency, Pulse Width, or Period
110	0	Engine Coolant Temperature	Coolant Temperature Low - Data Valid but Above Normal Operational Range - Most Severe Level
105	3	Intake Manifold #1 Temp	Intake Manifold Air Temperature Sensor Circuit - Voltage Above Normal, or Shorted to High Source
105	4	Intake Manifold #1 Temp	Intake Manifold Air Temperature Sensor Circuit - Voltage Below Normal, or Shorted to Low Source

J1939 SPN	J1939 FMI	J1939 SPN Description	Cummins Description
105	0	Intake Manifold #1 Temp	Intake Manifold Air Temperature High - Data Valid but Above Normal Operational Range - Most Severe Level
3510	4	5 Volts DC Supply	Sensor Supply Voltage #2 Circuit - Voltage Below Normal, or Shorted to Low Source
520199	3	Cruise Control	Cruise Control (Resistive) Signal Circuit - Voltage Above Normal, or Shorted to High Source
520199	4	Cruise Control	Cruise Control (Resistive) Signal Circuit - Voltage Below Normal, or Shorted to Low Source
111	3	Coolant Level	Coolant Level Sensor Circuit - Voltage Above Normal, or Shorted to High Source
111	4	Coolant Level	Coolant Level Sensor Circuit - Voltage Below Normal, or Shorted to Low Source
111	18	Coolant Level	Coolant Level - Data Valid but Below Normal Operational Range - Moderately Severe Level
1661	4	Engine Automatic Start Lamp	Engine Automatic Start Lamp Driver Circuit - Voltage Above Normal, or Shorted to High Source
1484	31	J1939 Error	Additional Auxiliary Diagnostic Codes logged - Condition Exists
175	3	Oil Temperature	Engine Oil Temperature Sensor 1 Circuit - Voltage Above Normal, or Shorted to High Source
175	4	Oil Temperature	Engine Oil Temperature Sensor 1 Circuit - Voltage Below Normal, or Shorted to Low Source
175	0	Oil Temperature	Engine Oil Temperature - Data Valid but Above Normal Operational Range - Most Severe Level
108	3	Barometric Pressure	Barometric Pressure Sensor Circuit - Voltage Above Normal, or Shorted to High Source
108	4	Barometric Pressure	Barometric Pressure Sensor Circuit - Voltage Below Normal, or Shorted to Low Source
3510	3	5 Volts DC Supply	Sensor Supply Voltage #2 Circuit - Voltage Above Normal, or Shorted to High Source
109	3	Coolant Pressure	Coolant Pressure Sensor Circuit - Voltage Above Normal, or Shorted to High Source
109	4	Coolant Pressure	Coolant Pressure Sensor Circuit - Voltage Below Normal, or Shorted to Low Source
109	18	Coolant Pressure	Coolant Pressure - Data Valid but Below Normal Operational Range - Moderately Severe Level
190	0	Engine Speed	Engine Speed High - Data Valid but Above Normal Operational Range - Most Severe Level
111	1	Coolant Level	Coolant Level Low - Data Valid but Below Normal Operational Range - Most Severe Level
644	2	External Speed Input	External Speed Input (Multiple Unit Synchronization) - Data Erratic, Intermittent, or Incorrect
3511	4	System Diagnostic code # 1	Sensor Supply Voltage #3 Circuit - Voltage Below Normal, or Shorted to Low Source
3511	3	System Diagnostic code #2	Sensor Supply Voltage #3 Circuit - Voltage Above Normal, or Shorted to High Source

J1939 SPN	J1939 FMI	J1939 SPN Description	Cummins Description
84	2	Wheel-based Vehicle Speed	Vehicle Speed Sensor Circuit - Data Erratic, Intermittent, or Incorrect
84	10	Wheel-based Vehicle Speed	Vehicle Speed Sensor Circuit tampering has been detected - Abnormal Rate of Change
623	4	Red Stop Lamp	Red Stop Lamp Driver Circuit - Voltage Below Normal, or Shorted to Low Source
647	4	Fan Clutch Output Device Driver	Fan Control Circuit - Voltage Below Normal, or Shorted to Low Source
171	3	Ambient Air Temperature	Ambient Air Temperature Sensor Circuit - Voltage Above Normal, or Shorted to High Source
171	4	Ambient Air Temperature	Ambient Air Temperature Sensor Circuit - Voltage Below Normal, or Shorted to Low Source
174	16	Fuel Temperature	Engine Fuel Temperature - Data Valid but Above Normal Operational Range - Moderately Severe Level
174	3	Fuel Temperature	Engine Fuel Temperature Sensor 1 Circuit - Voltage Above Normal, or Shorted to High Source
174	4	Fuel Temperature	Engine Fuel Temperature Sensor 1 Circuit - Voltage Below Normal, or Shorted to Low Source
94	2	Fuel Delivery Pressure	Fuel Pressure Sensor Circuit - Data Erratic, Intermittent, or Incorrect
1347	4	Fuel Pump Pressurizing Assembly #1	High Fuel Pressure Solenoid Valve Circuit - Voltage Below Normal, or Shorted to Low Source
1347	3	Fuel Pump Pressurizing Assembly #1	High Fuel Pressure Solenoid Valve Circuit - Voltage Above Normal, or Shorted to High Source
1347	7	Fuel Pump Pressurizing Assembly #1	High Fuel Pressure Solenoid Valve #1 - Mechanical System Not Responding Properly or Out of Adjustment
1043	4	Internal Sensor Voltage Supply	Engine Speed/Position Sensor (Crankshaft) Supply Voltage Circuit - Voltage Below Normal, or Shorted to Low Source
639	9	SAE J1939 Datalink	SAE J1939 Multiplexing PGN Timeout Error - Abnormal Update Rate
639	13	SAE J1939 Datalink	SAE J1939 Multiplexing Configuration Error - Out of Calibration
91	19	Accelerator Pedal Position	SAE J1939 Multiplexing Accelerator Pedal or Lever Sensor System Error - Received Network Data In Error
974	19	Remote Accelerator	SAE J1939 Multiplexing Remote Accelerator Pedal or Lever Data Error - Received Network Data In Error
441	14	Auxiliary Temperature 1	Auxiliary Temperature Sensor Input 1 - Special Instructions
441	3	OEM Temperature	Auxiliary Temperature Sensor Input # 1 Circuit - Voltage Above Normal, or Shorted to High Source
441	4	OEM Temperature	Auxiliary Temperature Sensor Input # 1 Circuit - Voltage Below Normal, or Shorted to Low Source

J1939 SPN	J1939 FMI	J1939 SPN Description	Cummins Description
108	2	Barometric Pressure	Barometric Pressure Sensor Circuit - Data Erratic, Intermittent, or Incorrect
1388	14	Auxiliary Pressure	Auxiliary Pressure Sensor Input 1 - Special Instructions
1388	3	Auxiliary Pressure	Auxiliary Pressure Sensor Input # 2 Circuit - Voltage Above Normal, or Shorted to High Source
1388	4	Auxiliary Pressure	Auxiliary Pressure Sensor Input # 2 Circuit - Voltage Below Normal, or Shorted to Low Source
251	2	Real Time Clock Power	Real Time Clock Power Interrupt - Data Erratic, Intermittent, or Incorrect
651	5	Injector Cylinder #01	Injector Solenoid Cylinder #1 Circuit – Current Below Normal, or Open Circuit
655	5	Injector Cylinder #05	Injector Solenoid Cylinder #5 Circuit - Current Below Normal, or Open Circuit
653	5	Injector Cylinder #03	Injector Solenoid Cylinder #3 Circuit - Current Below Normal, or Open Circuit
656	5	Injector Cylinder #06	Injector Solenoid Cylinder #6 Circuit - Current Below Normal, or Open Circuit
652	5	Injector Cylinder #02	Injector Solenoid Cylinder #2 Circuit - Current Below Normal, or Open Circuit
654	5	Injector Cylinder #04	Injector Solenoid Cylinder #4 Circuit - Current Below Normal, or Open Circuit
110	2	Engine Coolant Temperature	Coolant Temperature Sensor Circuit - Data Erratic, Intermittent, or Incorrect
1267	3	Vehicle Accessories Relay Driver	Idle Shutdown Vehicle Accessories Relay Driver Circuit - Voltage Above Normal, or Shorted to High Source
1267	4	Vehicle Accessories Relay Driver	Idle Shutdown Vehicle Accessories Relay Driver Circuit - Voltage Below Normal, or Shorted to Low Source
630	2	Calibration Memory	Engine Control Module data lost - Data Erratic, Intermittent, or Incorrect
630	13	Calibration Memory	Electronic Calibration Code Incompatibility - Out of Calibration
629	12	Controller #1	Engine Control Module Warning internal hardware failure - Bad Intelligent Device or Component
191	16	Transmission Output Shaft Speed	Transmission Output Shaft Speed - Data Valid but Above Normal Operational Range - Moderately Severe Level
627	12	Controller #1	Injector Power Supply - Bad Intelligent Device or Component
3509	4	5 Volts DC Supply	Sensor Supply Voltage #1 Circuit - Voltage Below Normal, or Shorted to Low Source
3509	3	5 Volts DC Supply	Sensor Supply Voltage #1 Circuit - Voltage Above Normal, or Shorted to High Source
100	1	Engine Oil Pressure	Oil Pressure Low - Data Valid but Below Normal Operational Range - Most Severe Level

J1939 SPN	J1939 FMI	J1939 SPN Description	Cummins Description
97	15	Water in Fuel Indicator	Water in Fuel Indicator High - Data Valid but Above Normal Operational Range - Least Severe Level
111	2	Coolant Level	Coolant Level - Data Erratic, Intermittent, or Incorrect
175	2	Oil Temperature	Engine Oil Temperature - Data Erratic, Intermittent, or Incorrect
97	3	Water in Fuel Indicator	Water in Fuel Sensor Circuit - Voltage Above Normal, or Shorted to High Source
97	4	Water in Fuel Indicator	Water in Fuel Sensor Circuit - Voltage Below Normal, or Shorted to Low Source
558	2	Accelerator Pedal Low Idle Switch	Accelerator Pedal or Lever Idle Validation Circuit - Data Erratic, Intermittent, or Incorrect
558	13	Accelerator Pedal Low Idle Switch	Accelerator Pedal or Lever Idle Validation Circuit - Out of Calibration
100	2	Engine Oil Pressure	Oil Pressure Sensor Circuit - Data Erratic, Intermittent, or Incorrect
168	18	Electrical Potential (Voltage)	Battery #1 Voltage Low - Data Valid but Below Normal Operational Range - Moderately Severe Level
168	16	Electrical Potential (Voltage)	Battery #1 Voltage High - Data Valid but Above Normal Operational Range - Moderately Severe Level
157	0	Injector Metering Rail 1 Pressure	Fuel Pressure High - Data Valid but Above Normal Operational Range - Moderately Severe Level
157	3	Injector Metering Rail 1 Pressure	Injector Metering Rail #1 Pressure Sensor Circuit - Voltage Above Normal, or Shorted to High Source
157	4	Injector Metering Rail 1 Pressure	Injector Metering Rail #1 Pressure Sensor Circuit - Voltage Below Normal, or Shorted to Low Source
105	16	Intake Manifold	Intake Manifold 1 Temperature - Data Valid but Above Normal Operational Range - Moderately Severe Level
191	18	Transmission Output Shaft Speed	Transmission Output Shaft Speed - Data Valid but Below Normal Operational Range - Moderately Severe Level
1377	2	Switch Circuit	Multiple Unit Synchronization Switch Circuit - Data Erratic, Intermittent, or Incorrect
611	2	System Diagnostic code # 1	OEM Intermediate (PTO) Speed switch Validation - Data Erratic, Intermittent, or Incorrect
702	3	Circuit - Voltage	Auxiliary Input/Output 2 Circuit - Voltage Above Normal, or Shorted to High Source
93	2	Switch - Data	Auxiliary Alternate Torque Validation Switch - Data Erratic, Intermittent, or Incorrect
703	3	Circuit - Voltage	Auxiliary Input/Output 3 Circuit - Voltage Above Normal, or Shorted to High Source
94	3	Fuel Delivery Pressure	Fuel Delivery Pressure Sensor Circuit - Voltage Above Normal, or Shorted to High Source
94	4	Fuel Delivery Pressure	Fuel Delivery Pressure Sensor Circuit - Voltage Below Normal, or Shorted to Low Source

J1939 SPN	J1939 FMI	J1939 SPN Description	Cummins Description
558	4	Accelerator Pedal Low Idle Switch	Accelerator Pedal or Lever Idle Validation Circuit - Voltage Below Normal, or Shorted to Low Source
157	16	Injector Metering Rail 1 Pressure	Injector Metering Rail #1 Pressure High - Data Valid but Above Normal Operational Range - Moderately Severe Level
157	2	Injector Metering Rail 1 Pressure	Fuel Pressure Sensor Error - Data Erratic, Intermittent, or Incorrect
157	18	Injector Metering Rail 1 Pressure	Injector Metering Rail #1 Pressure Low - Data Valid but Below Normal Operational Range - Moderately Severe Level
677	3	Starter Solenoid Lockout Relay Driver Circuit	Starter Relay Circuit - Voltage Above Normal, or Shorted to High Source
677	4	Starter Solenoid Lockout Relay Driver Circuit	Starter Relay Circuit - Voltage Below Normal, or Shorted to Low Source
103	16	Turbocharger 1 Speed	Turbocharger #1 Speed High - Data Valid but Above Normal Operational Range - Moderately Severe Level
167	16	Alternate Potential (voltage)	Electrical Charging System Voltage High - Data Valid but Above Normal Operational Range - Moderately Severe Level
167	18	Alternate Potential (voltage)	Electrical Charging System Voltage Low - Data Valid but Below Normal Operational Range - Moderately Severe Level
167	1	Alternate Potential (voltage)	Electrical Charging System Voltage Low - Data Valid but Below Normal Operational Range - Most Severe Level
640	14	Engine External Protection Input	Auxiliary Commanded Dual Output Shutdown - Special Instructions
1378	31	Engine Oil Change Interval	Change Lubricating Oil and Filter - Condition Exists
103	18	Turbocharger 1 Speed	Turbocharger #1 Speed Low - Data Valid but Below Normal Operational Range - Moderately Severe Level
190	2	Engine Speed	Primary Engine Speed Sensor Error - Data Erratic, Intermittent, or Incorrect
1172	3	Turbocharger #1 Compressor Inlet Temperature	Turbocharger #1 Compressor Inlet Temperature Sensor Circuit - Voltage Above Normal, or Shorted to High Source
1172	4	Turbocharger #1 Compressor Inlet Temperature	Turbocharger #1 Compressor Inlet Temperature Sensor Circuit - Voltage Below Normal, or Shorted to Low Source
1136	3	Sensor Circuit - Voltage	ECM Internal Temperature Sensor Circuit - Voltage Above Normal, or Shorted to High Source
1136	4	Sensor Circuit - Voltage	ECM Internal Temperature Sensor Circuit - Voltage Below Normal, or Shorted to Low Source
22	3	Crankcase Pressure	Extended Crankcase Blow-by Pressure Circuit - Voltage Above Normal, or Shorted to High Source
22	4	Crankcase Pressure	Extended Crankcase Blow-by Pressure Circuit - Voltage Below Normal, or Shorted to Low Source

J1939 SPN	J1939 FMI	J1939 SPN Description	Cummins Description
723	7	Engine Speed Sensor #2	Engine Speed/Position #2 mechanical misalignment between camshaft and crankshaft sensors - Mechanical System Not Responding Properly or Out of Adjustment
2802	31	Electronic Control Module	Electronic Control Module data lost - Condition Exists
723	2	Engine Speed Sensor #2	Engine Speed Sensor (Camshaft) Error - Data Erratic, Intermittent, or Incorrect
703	11	Auxiliary Equipment Sensor Input	Warning Auxiliary Equipment Sensor Input # 3 (OEM Switch) - Root Cause Not Known
166	2	Cylinder Power	Cylinder Power Imbalance Between Cylinders - Data Erratic, Intermittent, or Incorrect
627	2	Power Supply	Power Lost With Ignition On - Data Erratic, Intermittent, or Incorrect
651	7	Injector Cylinder # 01	Injector Cylinder #1 - Mechanical System Not Responding Properly or Out of Adjustment
652	7	Injector Cylinder # 02	Injector Cylinder #2 - Mechanical System Not Responding Properly or Out of Adjustment
653	7	Injector Cylinder # 03	Injector Cylinder #3 - Mechanical System Not Responding Properly or Out of Adjustment
654	7	Injector Cylinder # 04	Injector Cylinder #4 - Mechanical System Not Responding Properly or Out of Adjustment
655	7	Injector Cylinder # 05	Injector Cylinder #5 - Mechanical System Not Responding Properly or Out of Adjustment
656	7	Injector Cylinder # 06	Injector Cylinder #6 - Mechanical System Not Responding Properly or Out of Adjustment
2623	3	Accelerator Pedal Position	Accelerator Pedal or Lever Position Sensor 2 Circuit - Voltage Above Normal, or Shorted to High Source
2623	4	Accelerator Pedal Position	Accelerator Pedal or Lever Position Sensor 2 Circuit - Voltage Below Normal, or Shorted to Low Source
91	2	Accelerator Pedal Position	Accelerator Pedal or Lever Position Sensor 1 and 2 - Data Erratic, Intermittent, or Incorrect
1563	2	Control Module Identification Input State	Control Module Identification Input State Error - Data Erratic, Intermittent, or Incorrect
1563	2	Control Module Identification Input State	Control Module Identification Input State Error - Data Erratic, Intermittent, or Incorrect
97	16	Water in Fuel Indicator	Water in Fuel Indicator - Data Valid but Above Normal Operational Range - Moderately Severe Level
157	0	Injector Metering Rail	Injector Metering Rail 1 Pressure - Data Valid but Above Normal Operational Range - Most Severe Level
52	3	Coolant Temperature	Coolant Temperature 2 Sensor Circuit - Voltage Above Normal, or Shorted to High Source
52	4	Coolant Temperature	Coolant Temperature 2 Sensor Circuit - Voltage Below Normal, or Shorted to Low Source

J1939 SPN	J1939 FMI	J1939 SPN Description	Cummins Description
52	16	Coolant Temperature	Coolant Temperature 2 - Data Valid but Above Normal Operational Range - Moderately Severe Level
52	0	Coolant Temperature	Coolant Temperature 2 - Data Valid but Above Normal Operational Range - Most Severe Level
2981	3	Coolant Pressure	Coolant Pressure 2 Circuit - Voltage Above Normal, or Shorted to High Source
2981	4	Coolant Pressure	Coolant Pressure 2 Circuit - Voltage Below Normal, or Shorted to Low Source
2981	18	Coolant Pressure	Coolant Pressure 2 - Data Valid but Below Normal Operational Range - Moderately Severe Level
1072	3	Engine Brake Output # 1	Engine Brake Actuator Driver 1 Circuit - Voltage Above Normal, or Shorted to High Source
1072	4	Engine Brake Output # 1	Engine Brake Actuator Driver 1 Circuit - Voltage Below Normal, or Shorted to Low Source
3512	3	System Diagnostic code # 1	Sensor Supply Voltage #4 Circuit - Voltage Above Normal, or Shorted to High Source
3512	4	System Diagnostic code # 1	Sensor Supply Voltage #4 Circuit - Voltage Below Normal, or Shorted to Low Source
703	14	Auxiliary Equipment Sensor	Auxiliary Equipment Sensor Input 3 Engine Protection Critical - Special Instructions
94	18	Fuel Delivery Pressure	Fuel Pump Delivery Pressure - Data Valid but Below Normal Operational Range - Moderately Severe Level
94	1	Fuel Delivery Pressure	Fuel Pump Delivery Pressure - Data Valid but Above Normal Operational Range - Moderately Severe Level
630	31	Calibration Memory	ECM Program Memory (RAM) Corruption - Condition Exists
157	1	Injector Metering Rail 1 Pressure	Injector Metering Rail 1 Pressure - Data Valid but Below Normal Operational Range - Most Severe Level
94	15	Fuel Delivery Pressure	Fuel Pump Delivery Pressure - Data Valid but Above Normal Operational Range - Least Severe Level
94	17	Fuel Delivery Pressure	Fuel Pump Delivery Pressure - Data Valid but Below Normal Operational Range -Least Severe Level
1800	16	Battery Temperature	Battery Temperature - Data Valid but Above Normal Operational Range -Moderately Severe Level
1800	18	Battery Temperature	Battery Temperature - Data Valid but Below Normal Operational Range - Moderately Severe Level
1075	3	Electric Lift Pump for Engine Fuel	Fuel Priming Pump Control Signal Circuit - Voltage Above Normal, or Shorted to High Source
1075	4	Electric Lift Pump for Engine Fuel	Fuel Priming Pump Control Signal Circuit - Voltage Below Normal, or Shorted to Low Source
611	16	Fuel Inlet Meter Device	Fuel Inlet Meter Device - Data Valid but Above Normal Operational Range - Moderately Severe Level

J1939 SPN	J1939 FMI	J1939 SPN Description	Cummins Description
611	18	Fuel Inlet Meter Device	Fuel Inlet Meter Device flow demand lower than expected - Data Valid but Below Normal Operational Range - Moderately Severe Level
633	31	Fuel Control Valve #1	Fueling Actuator #1 Circuit Error - Condition Exists
190	2	Engine Speed	Engine Speed / Position Sensor #1 - Data Erratic, Intermittent, or Incorrect
723	2	Engine Speed Sensor #2	Engine Speed / Position Sensor #2 - Data Erratic, Intermittent, or Incorrect
103	10	Turbocharger 1 Speed	Turbocharger speed invalid rate of change detected - Abnormal Rate of Change
2789	15	System Diagnostic Code #1	Turbocharger Turbine Inlet Temperature (Calculated) - Data Valid but Above Normal Operational Range - Least Severe Level
2790	15	System Diagnostic Code #1	Turbocharger Compressor Outlet Temperature (Calculated) - Data Valid but Above Normal Operational Range - Least Severe Level
1073	4	Engine Compression Brake Output # 2	Engine Brake Actuator Circuit #2 - Voltage Below Normal, or Shorted to Low Source
1112	4	Engine Brake Output # 3	Engine Brake Actuator Driver Output 3 Circuit - Voltage Below Normal, or Shorted to Low Source
1073	3	Engine Compression Brake Output # 2	Engine Brake Actuator Circuit #2 - Voltage Above Normal, or Shorted to High Source
1112	3	Engine Brake Output # 3	Engine Brake Actuator Driver 3 Circuit - Voltage Above Normal, or Shorted to High Source
95	16	Engine Fuel Filter Differential Pressure	Fuel Filter Differential Pressure - Data Valid but Above Normal Operational Range - Moderately Severe Level
1209	3	Exhaust Gas Pressure	Exhaust Gas Pressure Sensor Circuit - Voltage Above Normal, or Shorted to High Source
1209	4	Exhaust Gas Pressure	Exhaust Gas Pressure Sensor Circuit - Voltage Below Normal, or Shorted to Low Source
412	3	Exhaust Gas Recirculation Temperature	Exhaust Gas Recirculation Temperature Sensor Circuit - Voltage Above Normal, or Shorted to High Source
412	4	Exhaust Gas Recirculation Temperature	Exhaust Gas Recirculation Temperature Sensor Circuit - Voltage Below Normal, or Shorted to Low Source
647	3	Fan Clutch Output Device Driver	Fan Control Circuit - Voltage Above Normal, or Shorted to High Source
730	4	Intake Air Heater # 2	Intake Air Heater 2 Circuit - Voltage Below Normal, or Shorted to Low Source
730	3	Intake Air Heater # 2	Intake Air Heater 2 Circuit - Voltage Above Normal, or Shorted to High Source
729	3	Inlet Air Heater Driver #1	Intake Air Heater #1 Circuit - Voltage Above Normal, or Shorted to High Source
729	4	Inlet Air Heater Driver #1	Intake Air Heater #1 Circuit - Voltage Below Normal, or Shorted to Low Source

J1939 SPN	J1939 FMI	J1939 SPN Description	Cummins Description
697	3	Auxiliary PWM Driver #1	Auxiliary PWM Driver #1 - Voltage Above Normal, or Shorted to High Source
697	4	Auxiliary PWM Driver #1	Auxiliary PWM Driver #1 - Voltage Below Normal, or Shorted to Low Source
110	15	Engine Coolant Temperature	Engine Coolant Temperature High - Data Valid but Above Normal Operational Range - Least Severe Level
102	2	Boost Pressure	Intake Manifold Pressure Sensor Circuit - Data Erratic, Intermittent, or Incorrect

8.1.2 TROUBLESHOOTING

Table 8.3 supplies the necessary indications for identifying the possible causes for inconveniences met during the use of the Induction Heating Generator IHG 120CU. Besides, both the remedies and the possible indication of the Paragraph, which reference shall be made to for the replacement procedure of the identified defective component, are indicated.



	<p>NOTE In order to get information about the failures possibly occurring to the engine, reference shall be made to the relevant “Owners Manual - QSB4.5 and 6.7”, delivered by TeSi s.r.l. as a Jointed Publication to this manual.</p>
---	---

Table 8.3 - Troubleshooting

INCONVENIENCE	POSSIBLE CAUSE	REMEDY
The display is OFF.	<p>a - The batteries switch is OFF.</p> <p>b - The main fuse F1 is blow out.</p> <p>c - Batteries are dead.</p>	<p>a - Switch ON the batteries switch (see Paragraph 6.4.1).</p> <p>b - Replace the F1 fuse (see Paragraph 7.7.2).</p> <p>c - Recharge or replace the batteries.</p>
Engine doesn't start.	<p>a - Batteries are dead.</p> <p>b - One of the emergency pushbuttons is pressed.</p> <p>c - There isn't any fuel inside the tank.</p> <p>d - Incorrect operation of the engine controller.</p> <p>e - The main fuse F1 is blow out.</p>	<p>a - Recharge or replace the batteries.</p> <p>b - Release the emergency pushbuttons, situated on the command and control panel and on the remote control and press RESET button.</p> <p>c - Check if there is any fuel inside the tank. Check if the correct fuel type is being used. Check the fuel plant tightness.</p> <p>d - Check the controller wiring (see Wiring Diagram), or replace it, if on failure.</p> <p>e - Replace the F1 fuse (see Paragraph 7.7.2).</p>
By pressing the “START” pushbutton, the heating cycle doesn't start.	<p>a - The message “The COIL is OPEN” is displayed. The clamp coil power supply circuit isn't closed.</p> <p>b - 10 seconds haven't yet elapsed, since the last “STOP” command.</p> <p>c - The control system is on failure.</p> <p>d - There is one at least one alarm active.</p>	<p>a - Check the clamp coil circuit (see Paragraph 8.1.1).</p> <p>b - Wait until 10 seconds have elapsed.</p> <p>c - Check, if possible, the generator control circuit (see Wiring Diagram), or contact the TeSi s.r.l. “After-Sales Technical Service”.</p> <p>d - Read on the display the alarm active and try to solve the problem by reading Paragraph 8.1.1.</p>

INCONVENIENCE	POSSIBLE CAUSE	REMEDY
<p>During the heating cycles, the engine doesn't keep the revolutions number constant.</p>	<p>a - Fuel level inside the tank is low. b - Engine control system is defective.</p>	<p>a - Refuel the tank. b - Check, if possible, the generator control circuit (see Wiring Diagram), contact the TeSi s.r.l. "After-Sales Technical Service" or if the problem persists, reference shall be made to the engine "Owners Manual - QSB4.5 and 6.7", for the anomalies possibly occurring to the same one.</p>
<p>The heating cycle is stopped without that the operator pressed the "STOP" pushbutton.</p>	<p>a - The Timer mode is ON.</p>  <p>Timer intervened. The display will show "CYCLE TIME ELAPSED" for a few seconds.</p> <p>b - There is one at least one alarm active.</p>	<p>a - Set timer mode OFF or set a time for the heating cycle duration longer than the actual one (see Paragraph 6.4.3.2, but still within the acceptable limits (see Electric Characteristics and duty cycle). b - Read on the display the alarm active and try to solve the problem by reading Paragraph 8.1.1.</p>
	<p>c - The "Temperature probe - Mode" (Optional) is "ON".</p>  <p>The pipe temperature has reached the preset value. The display will show "TEMPERATURE REACHED" for a few seconds.</p>	<p>c - Set "Temperature probe - Mode" = "OFF" (see Paragraph 6.4.6.4).</p>

Chapter

9

AVAILABLE OUTFITS

9.1 GENERAL

The present Chapter is not applicable to the Induction Heating Generator IHG 120CU.

Chapter

10

MAINTENANCE SERVICE TABLES

10.1 GENERAL

In this Chapter, the Tables for recording the maintenance interventions, are inserted.

After every intervention, the personnel who carried out the maintenance intervention shall fill the Table in every part and apply their own signature, as well as the company stamp, if the intervention was carried out by an external Company.

**NOTE**

The non-execution of the scheduled maintenance, which can be proved by the records reported in the relevant Tables prepared for that purpose, will automatically lead to immediate warranty decay.

<p>Date.....</p> <p>Company stamp/ Signature.....</p>	<p>Carried out maintenance interventions</p> <p>.....</p> <p>.....</p> <p>.....</p> <p>.....</p> <p>.....</p>
<p>Date.....</p> <p>Company stamp/ Signature.....</p>	<p>Carried out maintenance interventions</p> <p>.....</p> <p>.....</p> <p>.....</p> <p>.....</p> <p>.....</p>
<p>Date.....</p> <p>Company stamp/ Signature.....</p>	<p>Carried out maintenance interventions</p> <p>.....</p> <p>.....</p> <p>.....</p> <p>.....</p> <p>.....</p>
<p>Date.....</p> <p>Company stamp/ Signature.....</p>	<p>Carried out maintenance interventions</p> <p>.....</p> <p>.....</p> <p>.....</p> <p>.....</p> <p>.....</p>
<p>Date.....</p> <p>Company stamp/ Signature.....</p>	<p>Carried out maintenance interventions</p> <p>.....</p> <p>.....</p> <p>.....</p> <p>.....</p> <p>.....</p>
<p>Date.....</p> <p>Company stamp/ Signature.....</p>	<p>Carried out maintenance interventions</p> <p>.....</p> <p>.....</p> <p>.....</p> <p>.....</p> <p>.....</p>
<p>Date.....</p> <p>Company stamp/ Signature.....</p>	<p>Carried out maintenance interventions</p> <p>.....</p> <p>.....</p> <p>.....</p> <p>.....</p> <p>.....</p>

Date..... Company stamp/ Signature.....	Carried out maintenance interventions
Date..... Company stamp/ Signature.....	Carried out maintenance interventions
Date..... Company stamp/ Signature.....	Carried out maintenance interventions
Date..... Company stamp/ Signature.....	Carried out maintenance interventions
Date..... Company stamp/ Signature.....	Carried out maintenance interventions
Date..... Company stamp/ Signature.....	Carried out maintenance interventions
Date..... Company stamp/ Signature.....	Carried out maintenance interventions

Date..... Company stamp/ Signature.....	<div style="border: 1px solid black; padding: 5px;"> <p style="text-align: center;">Carried out maintenance interventions</p> <p>.....</p> <p>.....</p> <p>.....</p> <p>.....</p> <p>.....</p> </div>
Date..... Company stamp/ Signature.....	<div style="border: 1px solid black; padding: 5px;"> <p style="text-align: center;">Carried out maintenance interventions</p> <p>.....</p> <p>.....</p> <p>.....</p> <p>.....</p> <p>.....</p> </div>
Date..... Company stamp/ Signature.....	<div style="border: 1px solid black; padding: 5px;"> <p style="text-align: center;">Carried out maintenance interventions</p> <p>.....</p> <p>.....</p> <p>.....</p> <p>.....</p> <p>.....</p> </div>
Date..... Company stamp/ Signature.....	<div style="border: 1px solid black; padding: 5px;"> <p style="text-align: center;">Carried out maintenance interventions</p> <p>.....</p> <p>.....</p> <p>.....</p> <p>.....</p> <p>.....</p> </div>
Date..... Company stamp/ Signature.....	<div style="border: 1px solid black; padding: 5px;"> <p style="text-align: center;">Carried out maintenance interventions</p> <p>.....</p> <p>.....</p> <p>.....</p> <p>.....</p> <p>.....</p> </div>
Date..... Company stamp/ Signature.....	<div style="border: 1px solid black; padding: 5px;"> <p style="text-align: center;">Carried out maintenance interventions</p> <p>.....</p> <p>.....</p> <p>.....</p> <p>.....</p> <p>.....</p> </div>
Date..... Company stamp/ Signature.....	<div style="border: 1px solid black; padding: 5px;"> <p style="text-align: center;">Carried out maintenance interventions</p> <p>.....</p> <p>.....</p> <p>.....</p> <p>.....</p> <p>.....</p> </div>

Date..... Company stamp/ Signature.....	Carried out maintenance interventions
Date..... Company stamp/ Signature.....	Carried out maintenance interventions
Date..... Company stamp/ Signature.....	Carried out maintenance interventions
Date..... Company stamp/ Signature.....	Carried out maintenance interventions
Date..... Company stamp/ Signature.....	Carried out maintenance interventions
Date..... Company stamp/ Signature.....	Carried out maintenance interventions
Date..... Company stamp/ Signature.....	Carried out maintenance interventions

<p>Date.....</p> <p>Company stamp/ Signature.....</p>	<p>Carried out maintenance interventions</p> <p>.....</p> <p>.....</p> <p>.....</p> <p>.....</p>
<p>Date.....</p> <p>Company stamp/ Signature.....</p>	<p>Carried out maintenance interventions</p> <p>.....</p> <p>.....</p> <p>.....</p> <p>.....</p>
<p>Date.....</p> <p>Company stamp/ Signature.....</p>	<p>Carried out maintenance interventions</p> <p>.....</p> <p>.....</p> <p>.....</p> <p>.....</p>
<p>Date.....</p> <p>Company stamp/ Signature.....</p>	<p>Carried out maintenance interventions</p> <p>.....</p> <p>.....</p> <p>.....</p> <p>.....</p>
<p>Date.....</p> <p>Company stamp/ Signature.....</p>	<p>Carried out maintenance interventions</p> <p>.....</p> <p>.....</p> <p>.....</p> <p>.....</p>
<p>Date.....</p> <p>Company stamp/ Signature.....</p>	<p>Carried out maintenance interventions</p> <p>.....</p> <p>.....</p> <p>.....</p> <p>.....</p>
<p>Date.....</p> <p>Company stamp/ Signature.....</p>	<p>Carried out maintenance interventions</p> <p>.....</p> <p>.....</p> <p>.....</p> <p>.....</p>

Date..... Company stamp/ Signature.....	Carried out maintenance interventions
Date..... Company stamp/ Signature.....	Carried out maintenance interventions
Date..... Company stamp/ Signature.....	Carried out maintenance interventions
Date..... Company stamp/ Signature.....	Carried out maintenance interventions
Date..... Company stamp/ Signature.....	Carried out maintenance interventions
Date..... Company stamp/ Signature.....	Carried out maintenance interventions
Date..... Company stamp/ Signature.....	Carried out maintenance interventions

TeSi s.r.l. DECLINE ANY RESPONSIBILITY IN CASE OF DAMAGES TO EITHER PEOPLE OR THINGS DUE TO INOBSERVANCE OF THE DIRECTIVES AND INSTRUCTIONS CONTAINED IN THIS MANUAL OR IN THE INTEGRATIVE DOCUMENTS JOINTLY DELIVERED WITH THE COMPONENTS POSSIBLY COMPLETING THE INDUCTION HEATING GENERATOR IHG 120CU.

Publication No. 030113 - IHG 120CU Use and Maintenance Instructions

TeSi s.r.l.
Induction heating equipment

Via Piave, 20/11
20080 Vermezzo - Milano - Italy
<http://www.tesigroup.com>
e-mail: info@tesigroup.com

Reserved property. Reproduction, even partial, forbidden without written authorization issued by TeSi s.r.l.